

Disassembly and Assembly

1106A-70TA and 1106C-70TA Industrial Engines

PR (Engine)
PT (Engine)



Important Safety Information

Most accidents that involve product operation, maintenance and repair are caused by failure to observe basic safety rules or precautions. An accident can often be avoided by recognizing potentially hazardous situations before an accident occurs. A person must be alert to potential hazards. This person should also have the necessary training, skills and tools to perform these functions properly.

Improper operation, lubrication, maintenance or repair of this product can be dangerous and could result in injury or death.

Do not operate or perform any lubrication, maintenance or repair on this product, until you have read and understood the operation, lubrication, maintenance and repair information.

Safety precautions and warnings are provided in this manual and on the product. If these hazard warnings are not heeded, bodily injury or death could occur to you or to other persons.

The hazards are identified by the "Safety Alert Symbol" and followed by a "Signal Word" such as "DANGER", "WARNING" or "CAUTION". The Safety Alert "WARNING" label is shown below.



The meaning of this safety alert symbol is as follows:

Attention! Become Alert! Your Safety is Involved.

The message that appears under the warning explains the hazard and can be either written or pictorially presented.

Operations that may cause product damage are identified by "NOTICE" labels on the product and in this publication.

Perkins cannot anticipate every possible circumstance that might involve a potential hazard. The warnings in this publication and on the product are, therefore, not all inclusive. If a tool, procedure, work method or operating technique that is not specifically recommended by Perkins is used, you must satisfy yourself that it is safe for you and for others. You should also ensure that the product will not be damaged or be made unsafe by the operation, lubrication, maintenance or repair procedures that you choose.

The information, specifications, and illustrations in this publication are on the basis of information that was available at the time that the publication was written. The specifications, torques, pressures, measurements, adjustments, illustrations, and other items can change at any time. These changes can affect the service that is given to the product. Obtain the complete and most current information before you start any job. Perkins dealers or Perkins distributors have the most current information available.



When replacement parts are required for this product Perkins recommends using Perkins replacement parts.

Failure to heed this warning can lead to premature failures, product damage, personal injury or death.

Table of Contents

Disassembly and Assembly Section

Fuel Priming Pump - Remove and Install (Mechanical Priming Pump)	4
Fuel Filter Base - Remove and Install (Secondary Fuel Filter)	6
Water Separator and Fuel Filter (Primary) - Remove and Install	8
Fuel Injection Lines - Remove	11
Fuel Injection Lines - Install	13
Fuel Injection Pump - Remove (With Electronic Governor)	15
Fuel Injection Pump - Remove (With Boost Control)	17
Fuel Injection Pump - Install (With Electronic Governor)	19
Fuel Injection Pump - Install (With Boost Control) ..	21
Fuel Injection Pump Gear - Remove	23
Fuel Injection Pump Gear - Install	25
Fuel Injector - Remove	27
Fuel Injector - Install	28
Turbocharger - Remove (Turbocharger Top Mounted)	28
Turbocharger - Remove (Side Mounted Turbocharger)	30
Turbocharger - Install (Side Mounted Turbocharger)	31
Turbocharger - Install (Turbocharger Top Mounted)	32
Exhaust Manifold - Remove and Install (Top Mounted Exhaust Manifold)	35
Exhaust Manifold - Remove and Install (Side Mounted Turbocharger Exhaust Manifold)	37
Exhaust Elbow - Remove and Install	39
Inlet and Exhaust Valve Springs - Remove and Install	40
Inlet and Exhaust Valves - Remove and Install	43
Inlet and Exhaust Valve Guides - Remove and Install	46
Engine Oil Filter Base - Remove and Install	47
Engine Oil Cooler - Remove	48
Engine Oil Cooler - Install	49
Engine Oil Pump - Remove	50
Engine Oil Pump - Install	51
Water Pump - Remove	53
Water Pump - Install	54
Water Temperature Regulator - Remove and Install	56
Flywheel - Remove	57
Flywheel - Install	58
Crankshaft Rear Seal - Remove	59
Crankshaft Rear Seal - Install	60
Flywheel Housing - Remove and Install (Standard Housing)	61
Vibration Damper and Pulley - Remove	64
Vibration Damper and Pulley - Install	65
Crankshaft Front Seal - Remove and Install	66
Front Cover - Remove and Install	67
Gear Group (Front) - Remove and Install	68

Idler Gear - Remove	72
Idler Gear - Install	74
Housing (Front) - Remove	76
Housing (Front) - Install	78
Accessory Drive - Remove and Install (Accessory Drive SAE "A")	80
Crankcase Breather - Remove (Unfiltered Breather)	81
Crankcase Breather - Remove (Filtered Breather)	82
Crankcase Breather - Install (Filtered Breather) ...	83
Crankcase Breather - Install (Unfiltered Breather)	83
Valve Mechanism Cover - Remove and Install	84
Rocker Shaft and Pushrod - Remove	85
Rocker Shaft - Disassemble	86
Rocker Shaft - Assemble	87
Rocker Shaft and Pushrod - Install	88
Cylinder Head - Remove	89
Cylinder Head - Install	92
Lifter Group - Remove and Install	95
Camshaft - Remove and Install	96
Camshaft Gear - Remove and Install	99
Camshaft Bearings - Remove and Install	103
Engine Oil Pan - Remove (Cast Iron Oil Pan)	104
Engine Oil Pan - Remove (Aluminum Oil Pan) ...	105
Engine Oil Pan - Install (Cast Iron Oil Pan)	106
Engine Oil Pan - Install (Aluminum Oil Pan)	109
Piston Cooling Jets - Remove and Install	111
Pistons and Connecting Rods - Remove	112
Pistons and Connecting Rods - Disassemble	113
Pistons and Connecting Rods - Assemble	115
Pistons and Connecting Rods - Install	117
Connecting Rod Bearings - Remove (Connecting Rods in Position)	118
Connecting Rod Bearings - Install (Connecting Rods in Position)	119
Crankshaft Main Bearings - Remove and Install (Crankshaft in Position)	121
Crankshaft - Remove	126
Crankshaft - Install	129
Crankshaft Gear - Remove and Install	132
Bearing Clearance - Check	134
Glow Plugs - Remove and Install	135
V-Belts - Remove and Install	136
Fan - Remove and Install	137
Fan Drive - Remove and Install	138
Alternator - Remove	139
Alternator - Install	140
Electric Starting Motor - Remove and Install	141
Air Compressor - Remove and Install	142

Index Section

Index	148
-------------	-----

Disassembly and Assembly Section

i04473050

Fuel Priming Pump - Remove and Install (Mechanical Priming Pump)

Removal Procedure

Table 1

Required Tools			
Tool	Part Number	Part Description	Qty
A	T400106	Capping Kit	1

NOTICE

Ensure that all adjustments and repairs that are carried out to the fuel system are performed by authorized personnel that have the correct training.

Before beginning ANY work on the fuel system, refer to Operation and Maintenance Manual, "General Hazard Information and High Pressure Fuel Lines" for safety information.

Refer to System Operation, Testing and Adjusting, "Cleanliness of Fuel System Components" for detailed information on the standards of cleanliness that must be observed during ALL work on the fuel system.

1. Turn the fuel supply to the OFF position.

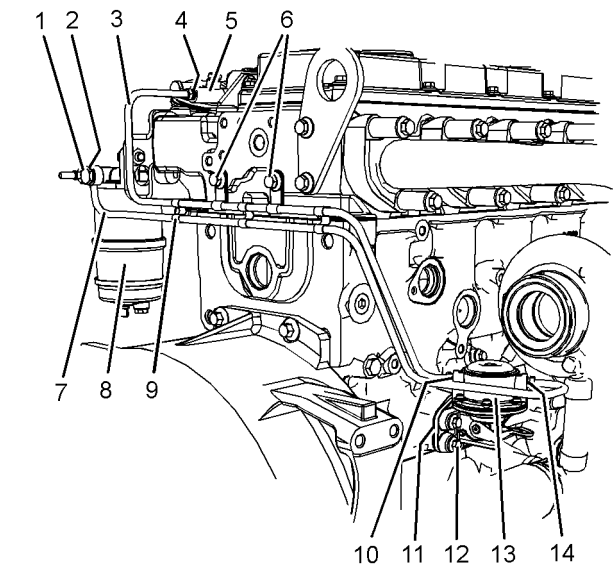

Illustration 1

g02686099

2. Make a temporary identification mark on tube assembly (3) and tube assembly (7).
3. Place a suitable container below primary fuel filter (8) in order to catch any fuel that might be spilled. Drain the primary fuel filter. Refer to Operation and Maintenance Manual, "Fuel System Primary Filter (Water Separator) Element - Replace" for the correct procedure.
4. Remove banjo bolt (1) and remove sealing washers (2) (not shown).
5. Remove clips (9) from tube assembly (3) and tube assembly (7).
6. Remove tube assembly (7) from fuel priming pump (13).
7. Remove seal (14) (not shown) from fuel priming pump (13).
8. Use Tooling (A) to plug fuel priming pump (13) and primary fuel filter (8).
9. Use Tooling (A) to cap tube assembly (7).
10. Remove bolts (6) from the tube clips.
11. Remove tube assembly (3) from fuel priming pump (13) and secondary fuel filter (5).
12. Remove seal (4) (not shown) and seal (10) (not shown) from fuel priming pump (13) and secondary fuel filter (5).
13. Use Tooling (A) to plug fuel priming pump (13) and secondary fuel filter (5).
14. Use Tooling (A) to cap tube assembly (3).

15. Remove bolts (12) from fuel priming pump (13).

Note: Support the fuel priming pump as the bolts are removed.

16. Remove fuel priming pump (13) from the cylinder block. Remove gasket (11) (not shown).

Installation Procedure

NOTICE

Ensure that all adjustments and repairs that are carried out to the fuel system are performed by authorized personnel that have the correct training.

Before beginning ANY work on the fuel system, refer to Operation and Maintenance Manual, "General Hazard Information and High Pressure Fuel Lines" for safety information.

Refer to System Operation, Testing and Adjusting, "Cleanliness of Fuel System Components" for detailed information on the standards of cleanliness that must be observed during ALL work on the fuel system.

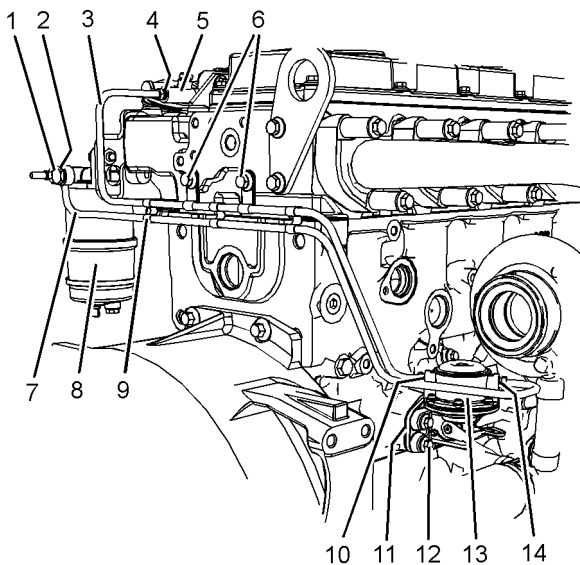

Illustration 2

g02686099

Typical example

1. Ensure that the gasket surface of the cylinder block is clean and free from damage.
2. Ensure that fuel priming pump (13) is clean and free from wear or damage. If necessary, replace the fuel priming pump.
3. Position a new gasket (11) (not shown) onto fuel priming pump (13).

4. Position fuel priming pump (13) onto the cylinder block.
5. Install bolts (12) to fuel priming pump (13) finger tight.
6. Tighten bolt (12) to a torque of 22 N·m (195 lb in).
7. Remove caps from tube assembly (3). Install new seal (4) (not shown) and seal (10) (not shown) to tube assembly (3).
8. Remove plugs from fuel priming pump (13) and secondary fuel filter (5).
9. Install tube assembly (3) to fuel priming pump (13) and secondary fuel filter (5).
10. Install bolts (6) to the tube clips.
11. Tighten the nuts on tube assembly (3) to a torque of 23 N·m (203 lb in).
12. Tighten bolt (6) to a torque of 44 N·m (32 lb ft).
13. Remove caps from tube assembly (7). Install new seal (14) (not shown) of tube assembly (7).
14. Remove plugs from fuel priming pump (13) and primary fuel filter (5).
15. Install tube assembly (7) to fuel priming pump (13) and primary fuel filter (8).
16. Position a new sealing washer (2) (not shown) onto banjo bolt (1). Install banjo bolt (1) to tube assembly (7) and position the remaining sealing washer (2) (not shown) onto banjo bolt (1).
17. Tighten banjo bolt (1) finger tight.
18. Install clips (9) to tube assembly (3) and tube assemblies (7).
19. Tighten the nuts on tube assembly (7) to a torque of 23 N·m (203 lb in).
20. Tighten banjo bolt (1) to a torque of 21 N·m (186 lb in).
21. Turn the fuel supply to the ON position.
22. Prime the fuel system. Refer to Operation and Maintenance Manual, "Fuel System - Prime".

i04473011

Fuel Filter Base - Remove and Install (Secondary Fuel Filter)

Removal Procedure

Table 2

Required Tools			
Tool	Part Number	Part Description	Qty
A	T400106	Capping Kit	1

NOTICE

Ensure that all adjustments and repairs that are carried out to the fuel system are performed by authorized personnel that have the correct training.

Before beginning ANY work on the fuel system, refer to Operation and Maintenance Manual, "General Hazard Information and High Pressure Fuel Lines" for safety information.

Refer to System Operation, Testing and Adjusting, "Cleanliness of Fuel System Components" for detailed information on the standards of cleanliness that must be observed during ALL work on the fuel system.

1. Turn the fuel supply to the OFF position.

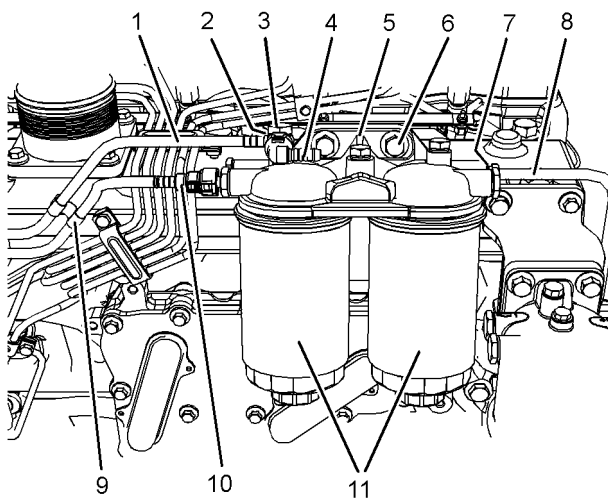

Illustration 3

g02688080

2. Place a suitable container below the fuel filter base in order to catch any fuel that might be spilled. Remove fuel filters (11). Refer to Operation and Maintenance Manual, "Fuel System Secondary Filter - Replace" for the correct procedure.
3. Make temporary identification marks on plastic tube assembly (1), plastic tube assembly (4), and plastic tube assembly (10) in order to show the correct position of the tube assemblies.
4. Remove tube clip (9) from plastic tube assembly (1) and plastic tube assembly (10).
5. Disconnect plastic tube assembly (4) from fuel filter base (5). Use Tooling (A) to cap the connection for plastic tube assembly (4).
6. Use Tooling (A) to cap plastic tube assembly (4).
7. Disconnect plastic tube assembly (10) from fuel filter base (5). Use Tooling (A) to plug fuel filter base (5).
8. Use Tooling (A) to cap plastic tube assembly (10).
9. Remove banjo bolt (3) and sealing washers (2) (not shown). Disconnect plastic tube assembly (1) from fuel filter base (5).
10. Use Tooling (A) to cap plastic tube assembly (1).
11. Use Tooling (A) to plug fuel filter base (5).
12. Disconnect tube assembly (8) from fuel filter base (5).
13. Remove the nuts and bolts (6) from fuel filter base (5). Remove fuel filter base (5) from the mounting bracket. Use Tooling (A) to plug fuel filter base (5).
14. Remove seal (7) (not shown) from fuel filter base (5). Use Tooling (A) to cap tube assembly (8).

Note: Do not disassemble the fuel filter base.

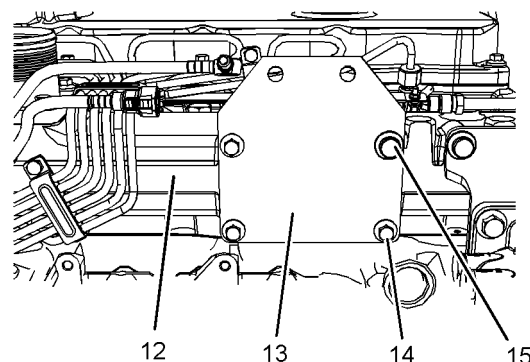

Illustration 4

g02688081

15. If necessary, remove the mounting bracket for the fuel filter from the cylinder head. Follow Step 15.a through Step 15.b in order to remove the mounting bracket for the fuel filter.
- Remove bolts (14) and bolt (15) from mounting bracket (13).
 - Remove mounting bracket (13) from cylinder head (12).

Note: Place temporary identification on mounting bracket in order to show the correct orientation

Installation Procedure

NOTICE

Ensure that all adjustments and repairs that are carried out to the fuel system are performed by authorized personnel that have the correct training.

Before beginning ANY work on the fuel system, refer to Operation and Maintenance Manual, "General Hazard Information and High Pressure Fuel Lines" for safety information.

Refer to System Operation, Testing and Adjusting, "Cleanliness of Fuel System Components" for detailed information on the standards of cleanliness that must be observed during ALL work on the fuel system.

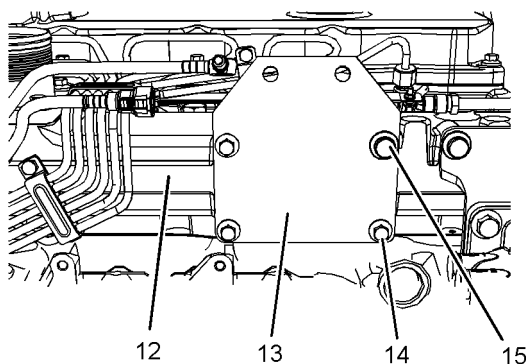

Illustration 5

g02688081

- If necessary, install the mounting bracket for the fuel filter to the cylinder head. Follow Step 1.a through Step 1.c in order to install the mounting bracket for the fuel filter.
 - Position mounting bracket (13) onto cylinder head (12).
- Note:** Ensure that the mounting bracket is correctly orientated.
- Install bolts (14) and bolt (15) to mounting bracket (13).

- Tighten bolts (14) to a torque of 22 N·m (195 lb in).

Tighten bolts (15) to a torque of 44 N·m (32 lb ft).

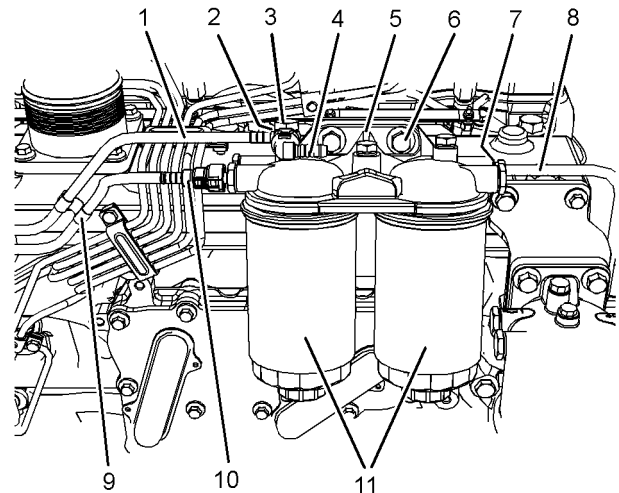

Illustration 6

g02688080

- Ensure that fuel filter base (5) is clean and free from damage. If necessary, replace the complete fuel filter base and filter assembly.
- Remove the cap from tube assembly (8).
- Remove the plug from fuel filter base (5). Install a new seal (7) (not shown) to fuel filter base (5).
- Position fuel filter base (5) onto the mounting bracket.
- Connect tube assembly (8) to fuel filter base (5).
- Install the nuts and bolts (6) to fuel filter base (5) finger tight.
- Tighten the nuts and bolts (6) to a torque of 44 N·m (32 lb ft).
- Tighten the nut for tube assembly (8) to a torque of 23 N·m (204 lb in).

NOTICE

Ensure that the plastic tube assemblies are installed in the original positions. Failure to connect the plastic tube assemblies to the correct ports will allow contamination to enter the fuel system. Fuel contaminated will result in serious damage to the engine.

- Remove the cap from plastic tube assembly (10). Connect plastic tube assembly (10) to fuel filter base (5).

11. Remove cap from plastic tube assembly (1)
12. Remove the plug from fuel filter base (5).
13. Position plastic tube assembly (1) onto fuel filter base (5).
14. Position a new sealing washer (2) (not shown) onto banjo bolt (3). Install banjo bolt (3) onto plastic tube assembly (1) and install the remaining new sealing washer (2) (not shown).
15. Tighten banjo bolt (3) to a torque of 21 N·m (186 lb in).
16. Install tube clip (9) to plastic tube assembly (1) and plastic tube assembly (10).
17. Remove the cap from plastic tube assembly (4).
18. Remove the plug from connection on plastic tube assembly (1).
19. Connect plastic tube assembly (4) to connection on plastic tube assembly (1).
20. If necessary, install a new fuel filters (11) to fuel filter base (5). Refer to Operation and Maintenance Manual, "Fuel System Secondary Filter - Replace" for the correct procedure.
21. Turn the fuel supply to the ON position.

End By:

- a. Remove the air from the fuel system. Refer to Operation and Maintenance Manual, "Fuel System - Prime" for the correct procedure.

i04473104

Water Separator and Fuel Filter (Primary) - Remove and Install

Removal Procedure

Table 3

Required Tools			
Tool	Part Number	Part Description	Qty
A	T400106	Capping Kit	1

NOTICE

Ensure that all adjustments and repairs that are carried out to the fuel system are performed by authorized personnel that have the correct training.

Before beginning ANY work on the fuel system, refer to Operation and Maintenance Manual, "General Hazard Information and High Pressure Fuel Lines" for safety information.

Refer to System Operation, Testing and Adjusting, "Cleanliness of Fuel System Components" for detailed information on the standards of cleanliness that must be observed during ALL work on the fuel system.

1. Turn the fuel supply to the OFF position.

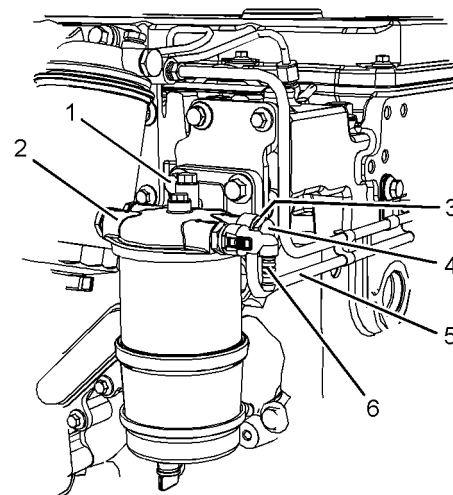

Illustration 7

g02689876

2. Make temporary identification marks on tube assembly and hose assembly in order to show the correct position.
3. Place a suitable container below the primary fuel filter in order to catch any fuel that might be spilled.
4. Disconnect hose assembly (6) from primary fuel filter (2).
5. Use Tooling (A) to plug the connection on primary fuel filter base (2).
6. Use Tooling (A) to cap hose assembly (6).
7. Remove banjo bolt (4) and sealing washers (3) (not shown).
8. Use Tooling (A) to cap tube assembly (5).

9. Use Tooling (A) to plug primary fuel filter base (2).
10. Remove bolts (1) and remove primary fuel filter (2) from the mounting bracket for the primary fuel filter.

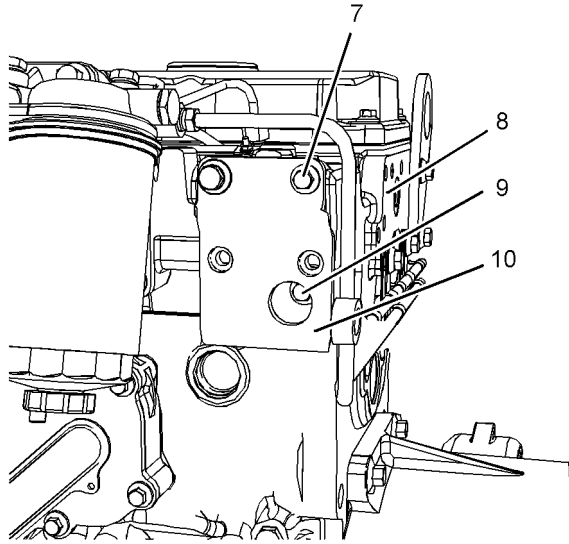

Illustration 8

g02689916

11. If necessary, remove the mounting bracket for the primary fuel filter from the cylinder head. Follow Step 3.a through Step 3.c in order to remove the mounting bracket for the primary fuel filter.
- Remove bolt (7) and bolts (9) from primary fuel filter mounting bracket (10).
 - Remove mounting bracket (12) from cylinder head (8).

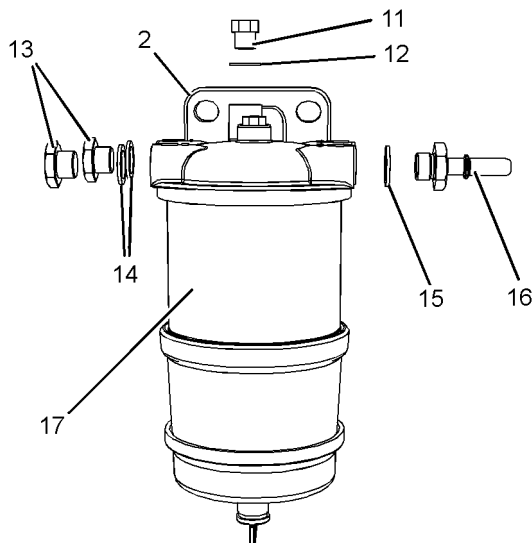

Illustration 9

g02689915

12. If necessary, follow Step 12.a through Step 12.d in order to disassemble primary fuel filter (2).
- Remove plug (11) and remove sealing washer (12). Use Tooling (A) to plug primary fuel filter base (2).
 - Remove connection (16) and remove seal washer (16). Use Tooling (A) to plug primary fuel filter base (2). Use Tooling (A) to cap connection (16).
 - Remove plugs (13) and remove sealing washers (14). Use Tooling (A) to plug primary fuel filter base (2).
 - Remove fuel filter element (17). Refer to Operation and Maintenance Manual, "Fuel System Primary Filter (Water Separator) Element - Replace" for the correct procedure.

Installation Procedure

NOTICE

Ensure that all adjustments and repairs that are carried out to the fuel system are performed by authorized personnel that have the correct training.

Before beginning ANY work on the fuel system, refer to Operation and Maintenance Manual, "General Hazard Information and High Pressure Fuel Lines" for safety information.

Refer to System Operation, Testing and Adjusting, "Cleanliness of Fuel System Components" for detailed information on the standards of cleanliness that must be observed during ALL work on the fuel system.

- Ensure that the primary fuel filter base is clean and free from damage. If necessary, replace the complete primary fuel filter base and filter assembly.

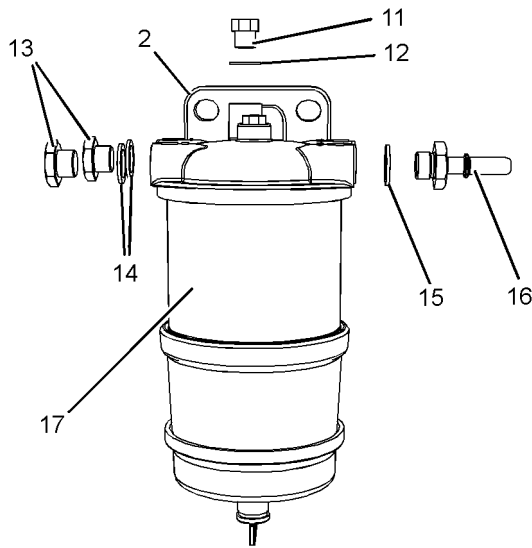

Illustration 10

g02689915

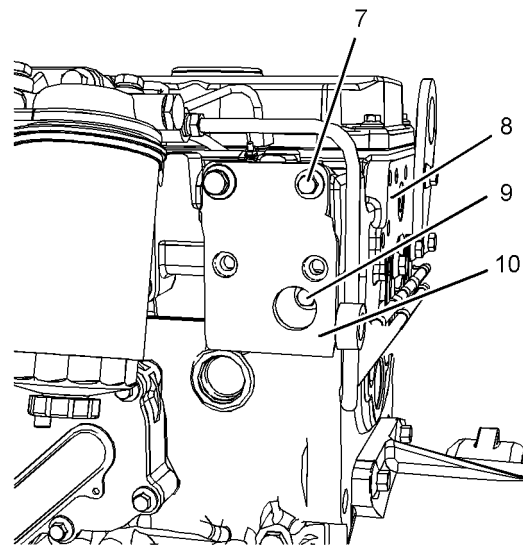

Illustration 11

g02689916

2. If necessary, follow Step 2.a through Step 2.d in order to assemble primary fuel filter (2).
 - a. Install a new sealing washer (12) to plug (11). Install plug (11) to primary fuel filter (2). Tighten the plug to a torque of 23 N·m (204 lb in).
 - b. Install a new sealing washer (15) to connection (16). Install connection (16) to primary fuel filter (2). Tighten the connection to a torque of 23 N·m (204 lb in).
 - c. Install new sealing washers (14) to plugs (13). Install plugs (13) to primary fuel filter (2). Tighten the plugs to a torque of 23 N·m (204 lb in).
 - d. Install a new filter element (17). Refer to Operation and Maintenance Manual, "Fuel System Primary Filter (Water Separator) Element - Replace" for the correct procedure.

3. If necessary, install the mounting bracket for the primary fuel filter to the cylinder head. Follow Step 3.a through Step 3.c in order to install the mounting bracket for the primary fuel filter.
 - a. Position primary fuel filter mounting bracket (10) onto cylinder head (8).
 - b. Install bolt (7) and bolts (9) to primary fuel filter mounting bracket (9).
 - c. Tighten bolt (7) to a torque of 44 N·m (32 lb ft).
Tighten bolts (9) to a torque of 22 N·m (195 lb in).

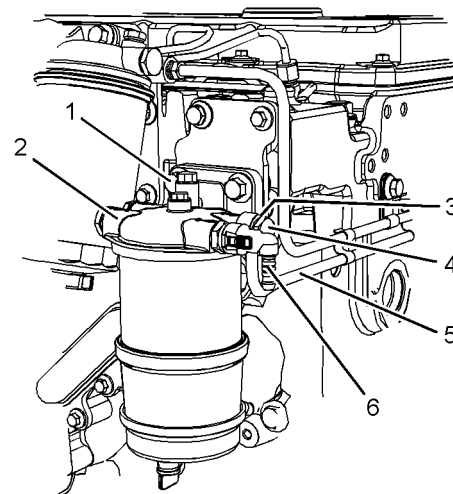

Illustration 12

g02689876

4. Position the assembly of primary fuel filter (2) onto the primary fuel filter mounting bracket.
5. Install bolts (1) to the assembly of primary fuel filter (2). Tighten the bolts to a torque of 44 N·m (32 lb ft).

NOTICE

Ensure that the plastic tube assemblies and tube assemblies are installed in the original positions. Failure to connect the plastic tube assemblies to the correct ports will allow contamination to enter the fuel system. Serious damage to the engine will result if contaminated fuel enters the fuel system.

6. Remove the plug from primary fuel filter base (2).
7. Remove the cap from tube assembly (5).
8. Position a new sealing washer (3) (not shown) onto banjo bolt (4). Install banjo bolt (4) onto tube assembly (5) and install the remaining new sealing washer (3) (not shown). Tighten banjo bolt (4) finger tight.
9. Tighten banjo bolt (4) to a torque of 21 N·m (186 lb in).
10. Remove the cap from hose assembly (5).
11. Remove the plug from connection on primary fuel filter base (2).
12. Connect hose assembly (5) to the connection on primary fuel filter base (2)
13. Turn the fuel supply to the ON position.

End By:

- a. Remove the air from the fuel system. Refer to Operation and Maintenance Manual, "Fuel System - Prime" for the correct procedure.

i04473013

Fuel Injection Lines - Remove

Removal Procedure

Table 4

Required Tools			
Tool	Part Number	Part Description	Qty
A	T400106	Capping Kit	1
B	T400030	Injector Pipe Nut Tool	1

! WARNING

Contact with high pressure fuel may cause fluid penetration and burn hazards. High pressure fuel spray may cause a fire hazard. Failure to follow these inspection, maintenance and service instructions may cause personal injury or death.

NOTICE

Ensure that all adjustments and repairs that are carried out to the fuel system are performed by authorized personnel that have the correct training.

Before beginning ANY work on the fuel system, refer to Operation and Maintenance Manual, "General Hazard Information and High Pressure Fuel Lines" for safety information.

Refer to System Operation, Testing and Adjusting, "Cleanliness of Fuel System Components" for detailed information on the standards of cleanliness that must be observed during ALL work on the fuel system.

NOTICE

Care must be taken to ensure that fluids are contained during performance of inspection, maintenance, testing, adjusting and repair of the product. Be prepared to collect the fluid with suitable containers before opening any compartment or disassembling any component containing fluids.

Dispose of all fluids according to local regulations and mandates.

1. Turn the fuel supply to the OFF position.
-

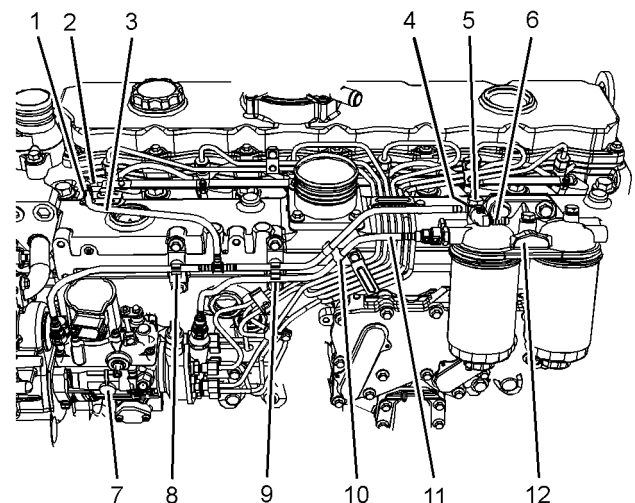

Illustration 13

g02720484

2. Disconnect hose assembly (2) from the fuel injector. Remove plastic tube assembly (3) from clip (1).
3. Use Tooling (A) to cap the fuel injector. Use Tooling (A) to plug hose assembly (2).
4. Disconnect hose assembly (6) from the connection on plastic tube assembly (3).
5. Use Tooling (A) to cap the connection on plastic tube assembly (3). Use Tooling (A) to plug hose assembly (6).
6. Remove banjo bolt (5) and remove sealing washers (4) (not shown).
7. Use Tooling (A) plug plastic tube assembly (3). Use Tooling (A) plug fuel filter base (12).
8. Remove clip (10) from plastic tube assembly (3) and plastic tube assembly (11).
9. Remove plastic tube assembly (3) and plastic tube assembly (11) from clip (8) and clips (9).
10. Disconnect plastic tube assembly (11) from fuel filter base (12).
11. Use Tooling (A) plug fuel filter base (12). Use Tooling (A) cap plastic tube assembly (11).
12. Disconnect plastic tube assembly (3) and plastic tube assembly (11) from fuel injection pump (7).
13. Use Tooling (A) to cap the connections on fuel injection pump (7).
14. Use Tooling (A) to plug plastic tube assembly (3) and plastic tube assembly (11).

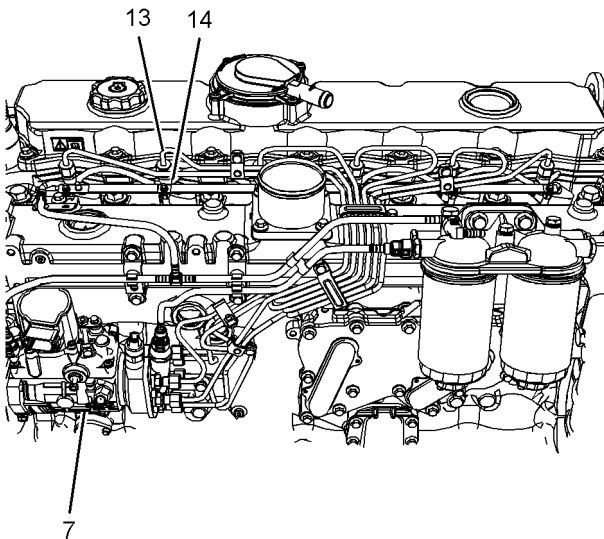

Illustration 14

g02692736

15. Disconnect fuel injection lines (13) from fuel injectors (14).
16. Use Tooling (B) in order to disconnect fuel injection lines (13) from fuel injection pump (7).
17. Remove fuel injection line (13) as an assembly.
18. Use Tooling (A) in order to cap ports of fuel injectors (14).
19. Use Tooling (A) in order to cap ports of fuel injection pump (7).

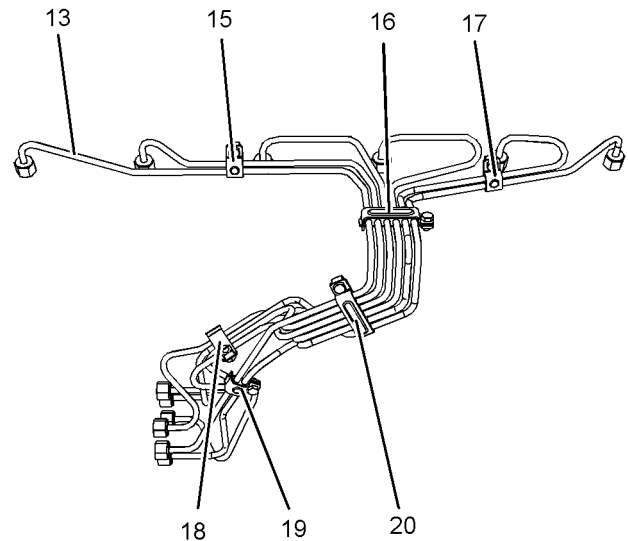

Illustration 15

g02692776

20. If necessary, follow Step 20.a through Step 20.c in order to disassemble the fuel injection line assembly.
 - a. Make temporary identification marks on all the clamps to show position and orientation prior to removal. Remove clamp (15), clamp (16) and clamp (17) from fuel injection lines (13).
 - b. Make temporary identification marks on all the clamps to show position and orientation prior to removal. Remove clamp (18), clamp (19) and clamp (20) from fuel injection lines (13).
 - c. Remove fuel injection lines (13).

Note: Make temporary identification marks on all the fuel injection lines prior to removal.

i04473012

Fuel Injection Lines - Install

Installation Procedure

Table 5

Required Tools			
Tool	Part Number	Part Description	Qty
A	T400030	Injector Pipe Nut Tool	1

NOTICE

Ensure that all adjustments and repairs that are carried out to the fuel system are performed by authorized personnel that have the correct training.

Before beginning ANY work on the fuel system, refer to Operation and Maintenance Manual, "General Hazard Information and High Pressure Fuel Lines" for safety information.

Refer to System Operation, Testing and Adjusting, "Cleanliness of Fuel System Components" for detailed information on the standards of cleanliness that must be observed during ALL work on the fuel system.

1. Ensure that all the fuel injection lines are clean and free from damage. Replace any fuel injection lines that are worn or damaged.

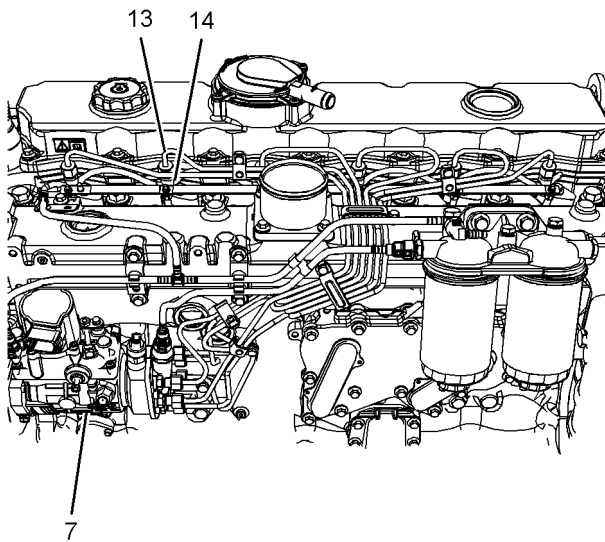

Illustration 16

g02692736

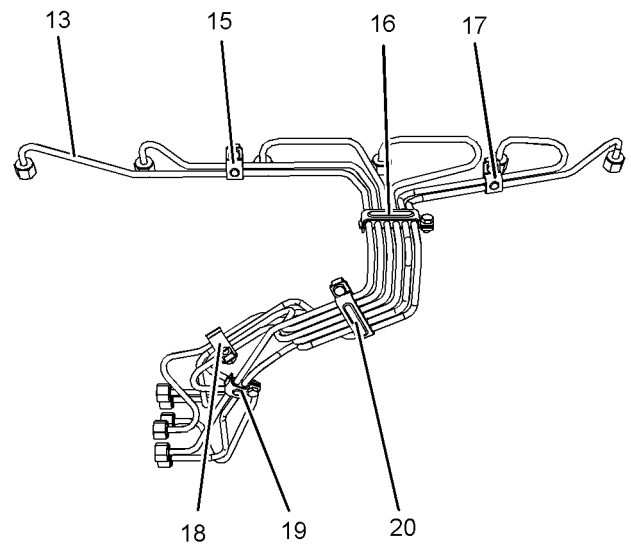

Illustration 17

g02692776

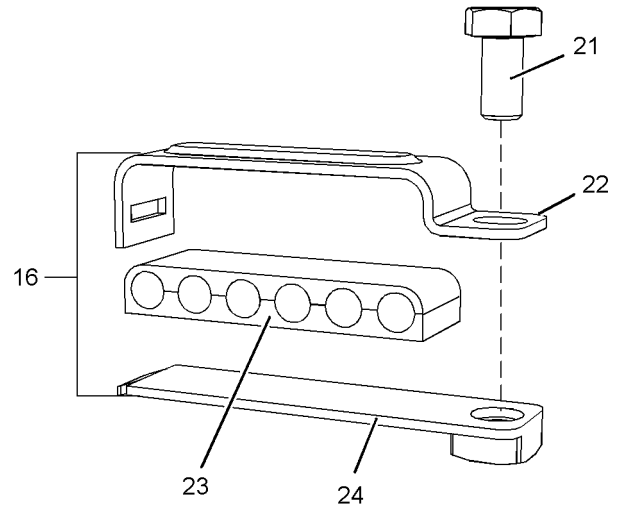

Illustration 18

g02720972

Typical Example

2. If necessary, follow Step 2.a through Step 2.d in order to assemble the fuel injection lines.

- a. Assemble fuel injection lines (13) into the correct order.
- b. Install isolator (23) for clamp (16) to fuel injection lines (13).

Note: Ensure that the isolator is correctly position and oriented onto fuel injection lines.

- c. Position top section (22) onto isolator (23) and install bottom section (24) to top section (22). Loosely install bolt (21) hand tight.

d. Repeat Step 2.a through Step 2.c in order to install the remaining clamp (15), clamp (17), clamp (18), clamp (19), and clamp (20).

1. Remove the caps from the ports of fuel injectors (14). Remove the caps from the ports of fuel injection pump (7).
2. Remove the caps from fuel injection lines (13)
3. Loosely position the assembly of fuel injection lines (13) onto fuel injection pump (7) and fuel injectors (14). Tighten the nut for fuel injection line (13) hand tight.

Note: Ensure that the fuel injection lines are correctly seated into the connections for the fuel injection pump and the fuel injectors.

4. Use Tooling (B) to tighten the nuts on fuel injection line (13) to a torque of 34 N·m (301 lb in).

Note: Ensure that the fuel injection lines do not contact any other engine component.

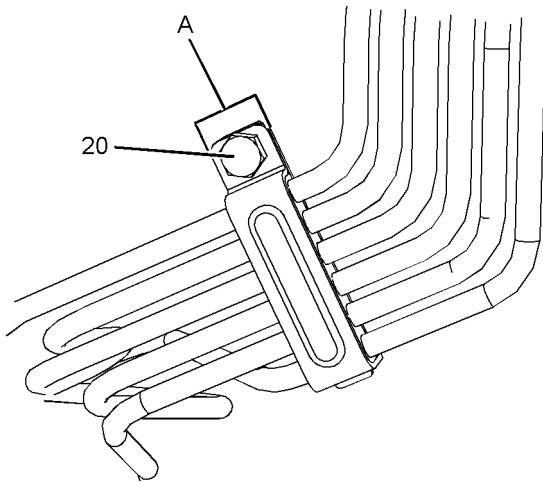

Illustration 19

g02720997

5. Use a suitable tool in order to hold the clamps in Position (A). Tighten bolts (20) for the clamps to a torque of 9 N·m (80 lb in).

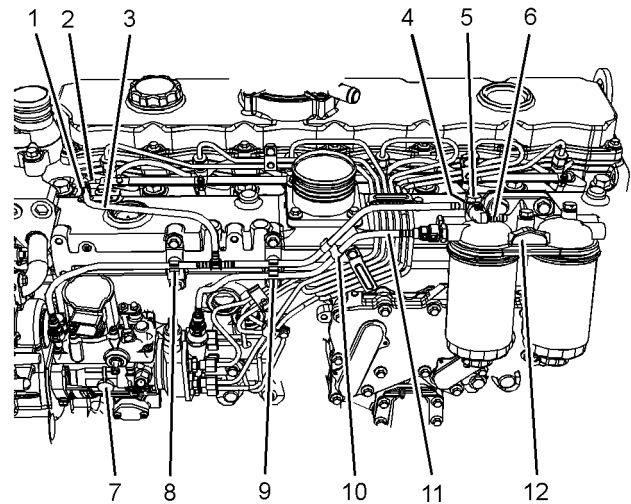

Illustration 20

g02720484

6. Remove the plug from fuel filter base (12). Remove the cap from plastic tube assembly (11). Remove the cap from the connections on fuel injection pump (7).
7. Connect plastic tube assembly (11) to fuel filter base (12) and fuel injection pump (7). Install plastic tube assembly (11) to clip (9).
8. Remove the plug from fuel filter base (12). Remove the cap from plastic tube assembly (3).
9. Connect plastic tube assembly (3) to fuel injection pump (7).
10. Position a new sealing washer (4) (not shown) onto banjo bolt (5). Install banjo bolt (5) onto plastic tube assembly (3) and install the remaining new sealing washer (4) (not shown).
11. Install plastic tube assembly (3) to clip (8) and clip (9).
12. Tighten banjo bolt (5) to a torque of 21 N·m (186 lb in).
13. Connect hose assembly (6) to the connection on plastic tube assembly (3).
14. Connect hose assembly (2) to the fuel injector. Install plastic tube assembly (3) to clip (3).
15. Install clip (10) to plastic tube assembly (3) and plastic tube assembly (11).
16. Turn the fuel supply to the ON position.
17. Remove the air from the fuel system. Refer to Operations and Maintenance Manual, "Fuel System - Prime".

i04473029

Fuel Injection Pump - Remove (With Electronic Governor)

Removal Procedure

Table 6

Required Tools			
Tool	Part Number	Part Description	Qty
A ⁽¹⁾	T400011	Crankshaft Turning Tool	1
A ⁽²⁾	27610291	Housing	1
	27610289	Engine Turning Tool	1
B	27610286	Timing Pin (Crankshaft)	1
C	27610212	Timing Pin (Camshaft)	1
D	T400106	Capping Kit	1

⁽¹⁾ The Crankshaft Turning Tool is used on the front pulley.

⁽²⁾ This Tool is used in the aperture for the electric starting motor.

Start By:

- a. Remove the front cover. Refer to Disassembly and Assembly, "Front Cover - Remove and Install" for the correct procedure .
- b. Remove the fuel injection lines. Refer to Disassembly and Assembly, "Fuel Injection Lines - Remove" for the correct procedure.

Note: Either Tooling (A) can be used. Use the Tooling that is most suitable.

WARNING

Contact with high pressure fuel may cause fluid penetration and burn hazards. High pressure fuel spray may cause a fire hazard. Failure to follow these inspection, maintenance and service instructions may cause personal injury or death.

NOTICE

Ensure that all adjustments and repairs that are carried out to the fuel system are performed by authorized personnel that have the correct training.

Before beginning ANY work on the fuel system, refer to Operation and Maintenance Manual, "General Hazard Information and High Pressure Fuel Lines" for safety information.

Refer to System Operation, Testing and Adjusting, "Cleanliness of Fuel System Components" for detailed information on the standards of cleanliness that must be observed during ALL work on the fuel system.

1. Turn the fuel supply to the OFF position.
2. Turn the battery disconnect switch to the OFF position.

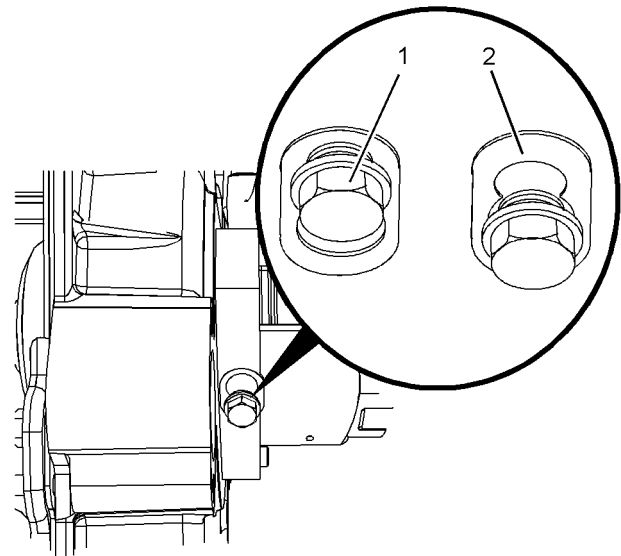

Illustration 21

g02695477

3. Use Tooling (A) in order to rotate the crankshaft so that number one piston is at top dead center position . Refer to System Operation, Testing and Adjusting, "Finding Top Center Position for No. 1 Piston" for the correct procedure.
4. Use Tooling (B) in order to lock the crankshaft so that number one piston is at top dead center position.
5. Use Tooling (C) in order to lock the camshaft.

6. Loosen locking screw (1). Rotate spacer (2) in order to allow locking screw (1) to tighten against the shaft of the fuel injection pump. Rotate the fuel injection pump gear in a counterclockwise direction in order to remove the backlash. Tighten locking screw (1) to a torque of 15 N·m (133 lb in).

Note: Locking the screw must be tightened in order to prevent the shaft of the fuel injection pump from rotating. The shaft of the fuel injection pump must not be rotated after the fuel injection pump has been removed from the engine.

7. Remove the backlash from the fuel pump gear. Lock the fuel injection pump in the correct position and remove the fuel pump gear. Refer to Disassembly and Assembly, "Fuel Pump Gear - Remove and Install" for the correct procedure.

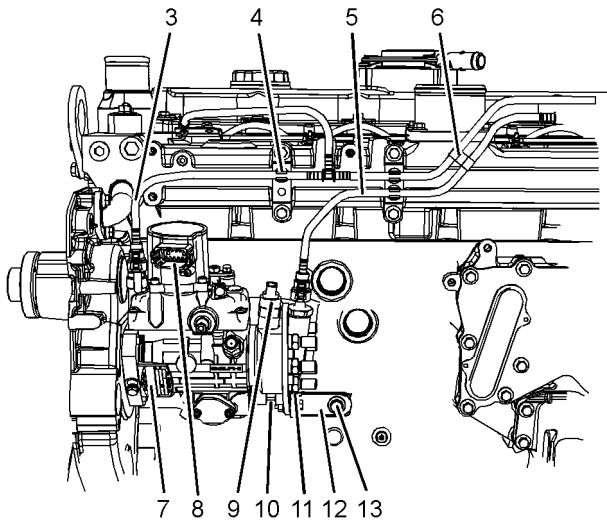

Illustration 22

g02695396

8. Clean fuel injection pump (7) and the area around the fuel injection pump. Ensure that the area is free from contamination before beginning disassembly.
9. Place a suitable container below fuel injection pump (7) in order to catch any fuel that might be spilled.
10. Disconnect plastic tube assembly (3), and plastic tube assembly (5) from fuel injection pump (7).
11. Remove plastic tube assembly (3), and plastic tube assembly (5) from clips (4) and clip (6). Position the plastic tube assemblies away from the fuel injection pump.
12. Use Tooling (D) in order to plug plastic tube assembly (3), and plastic tube assembly (5).
13. Use Tooling (D) in order to cap connection for the plastic tube assemblies on fuel injection pump (7).

14. Disconnect the Original Equipment Manufactures (OEM) harness assembly from governor (8).

15. Disconnect the OEM harness assemblies from solenoid (9) and solenoid (10).

16. If necessary, disconnect the OEM harness assemblies from solenoid (10).

17. Remove the nut and bolt (11) from fuel injection pump (7).

18. Remove bolt (13) and remove bracket (12) from the cylinder block and the fuel injection pump.

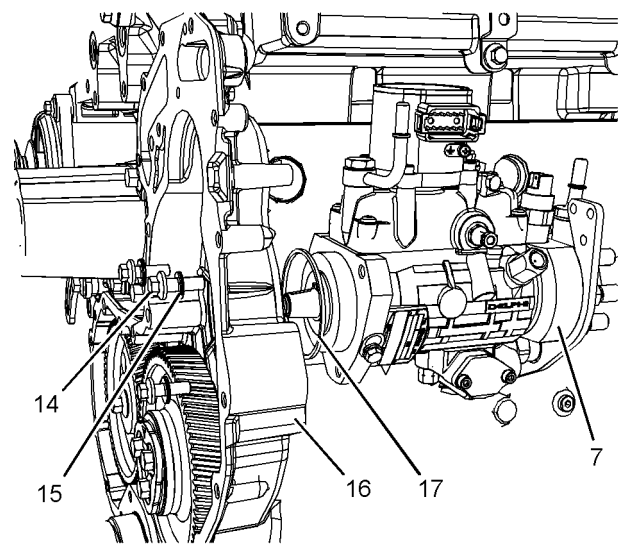

Illustration 23

g02695516

19. Remove bolts (14) and sealing washers (15) from fuel injection pump (7).

Note: The fuel injection pump should be supported by hand as the bolts are removed.

20. Carefully remove fuel injection pump (7) from front housing (16).

21. Remove O-ring seal (17) from fuel injection pump (7).

i04656189

Fuel Injection Pump - Remove (With Boost Control)

Removal Procedure

Table 7

Required Tools			
Tool	Part Number	Part Description	Qty
A ⁽¹⁾	T400011	Crankshaft Turning Tool	1
A ⁽²⁾	27610291	Housing	1
	27610289	Engine Turning Tool	1
B	27610286	Timing Pin (Crankshaft)	1
C	27610212	Timing Pin (Camshaft)	1
D	T400106	Capping Kit	1

⁽¹⁾ The Crankshaft Turning Tool is used on the front pulley.

⁽²⁾ This Tool is used in the aperture for the electric starting motor.

Start By:

- a. Remove the front cover. Refer to Disassembly and Assembly, "Front Cover - Remove and Install" for the correct procedure .
- b. Remove the fuel injection lines. Refer to Disassembly and Assembly, "Fuel Injection Lines - Remove" for the correct procedure.

Note: Either Tooling (A) can be used. Use the Tooling that is most suitable.

WARNING

Contact with high pressure fuel may cause fluid penetration and burn hazards. High pressure fuel spray may cause a fire hazard. Failure to follow these inspection, maintenance and service instructions may cause personal injury or death.

NOTICE

Ensure that all adjustments and repairs that are carried out to the fuel system are performed by authorized personnel that have the correct training.

Before beginning ANY work on the fuel system, refer to Operation and Maintenance Manual, "General Hazard Information and High Pressure Fuel Lines" for safety information.

Refer to System Operation, Testing and Adjusting, "Cleanliness of Fuel System Components" for detailed information on the standards of cleanliness that must be observed during ALL work on the fuel system.

1. Turn the fuel supply to the OFF position.
2. Turn the battery disconnect switch to the OFF position.

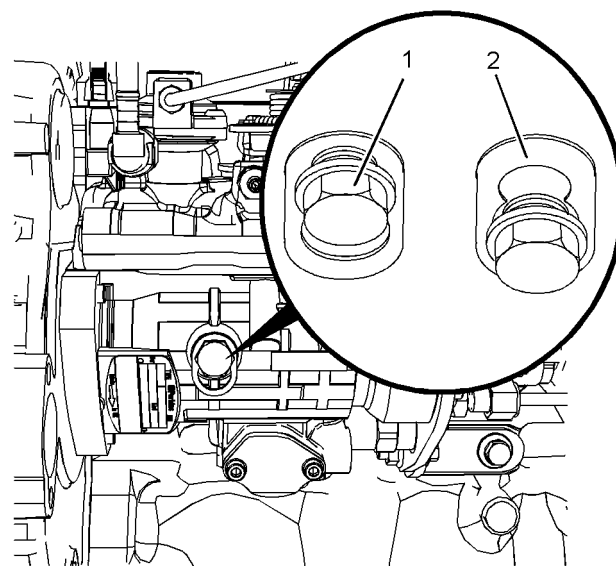

Illustration 24

g02791601

3. Use Tooling (A) in order to rotate the crankshaft so that number one piston is at top dead center position . Refer to System Operation, Testing and Adjusting, "Finding Top Center Position for No. 1 Piston" for the correct procedure.
4. Use Tooling (B) in order to lock the crankshaft so that number one piston is at top dead center position.
5. Use Tooling (C) in order to lock the camshaft.

6. Loosen locking screw (1). Rotate spacer (2) in order to allow locking screw (1) to tighten against the shaft of the fuel injection pump. Rotate the fuel injection pump gear in a counterclockwise direction in order to remove the backlash. Tighten locking screw (1) to a torque of 15 N·m (133 lb in).

Note: Locking the screw must be tightened in order to prevent the shaft of the fuel injection pump from rotating. The shaft of the fuel injection pump must not be rotated after the fuel injection pump has been removed from the engine.

7. Remove the backlash from the fuel pump gear. Lock the fuel injection pump in the correct position and remove the fuel pump gear. Refer to Disassembly and Assembly, "Fuel Pump Gear - Remove and Install" for the correct procedure.

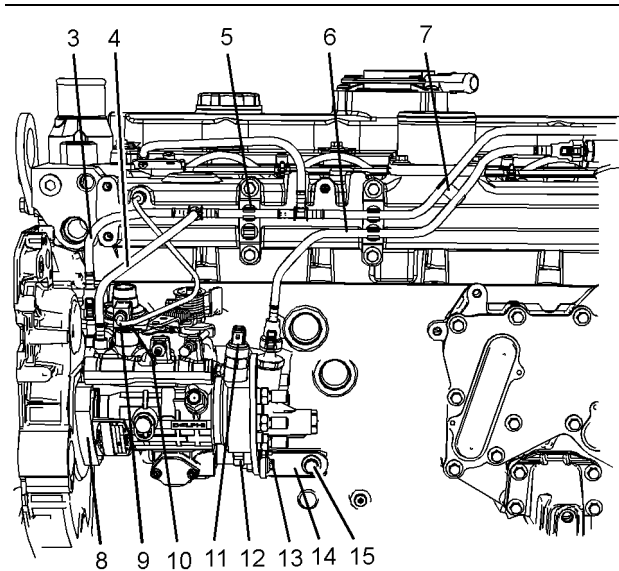

Illustration 25

g02791603

8. Clean fuel injection pump (8) and the area around the fuel injection pump. Ensure that the area is free from contamination before beginning disassembly.
9. Place a suitable container below fuel injection pump (8) in order to catch any fuel that might be spilled.
10. Disconnect plastic tube assembly (3), plastic tube assembly (4), and plastic tube assembly (6) from fuel injection pump (8).
11. Remove plastic tube assembly (3), plastic tube assembly (4), and plastic tube assembly (6) from clips (5) and clip (7). Position the plastic tube assemblies away from the fuel injection pump.
12. Use Tooling (D) in order to plug plastic tube assembly (3), plastic tube assembly (4), and plastic tube assembly (6).

13. Use Tooling (D) in order to cap connections for the plastic tube assemblies on fuel injection pump (8).

14. Remove tube assembly (9) from fuel injection pump (8) and the cylinder head.

15. Remove seal (10) (not shown).

16. Disconnect the OEM harness assemblies from solenoid (11) and solenoid (12).

17. Remove the nut and bolt (13) from fuel injection pump (8).

18. Remove bolt (15) and remove bracket (14) from the cylinder block and the fuel injection pump.

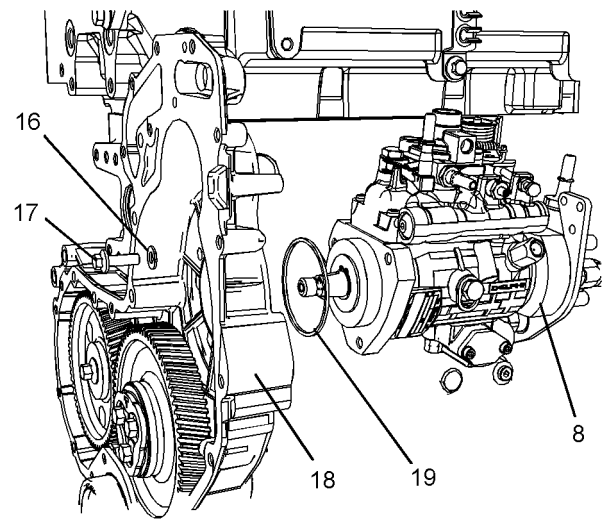

Illustration 26

g02791604

19. Remove bolts (17) and sealing washers (16) from fuel injection pump (8).

Note: The fuel injection pump should be supported by hand as the bolts are removed.

20. Carefully remove fuel injection pump (8) from front housing (18).

21. Remove O-ring seal (19) from fuel injection pump (8).

i04473014

Fuel Injection Pump - Install (With Electronic Governor)

Installation Procedure

Table 8

Required Tools			
Tool	Part Number	Part Description	Qty
A ⁽¹⁾	T400011	Crankshaft Turning Tool	1
A ⁽²⁾	27610291	Housing	1
	27610289	Engine Turning Tool	1
B	27610286	Timing Pin (Crankshaft)	1
C	27610212	Timing Pin (Camshaft)	1

- (1) The Crankshaft Turning Tool is used on the front pulley.
- (2) This Tool is used in the aperture for the electric starting motor.

Note: Either Tooling (A) can be used. Use the Tooling that is most suitable.

NOTICE

Ensure that all adjustments and repairs that are carried out to the fuel system are performed by authorized personnel that have the correct training.

Before beginning ANY work on the fuel system, refer to Operation and Maintenance Manual, "General Hazard Information and High Pressure Fuel Lines" for safety information.

Refer to System Operation, Testing and Adjusting, "Cleanliness of Fuel System Components" for detailed information on the standards of cleanliness that must be observed during ALL work on the fuel system.

1. Inspect the bore in the front housing for damage. If the bore is damaged, replace the front housing. Refer to Disassembly and Assembly, "Housing (Front) - Remove" for the correct procedure.

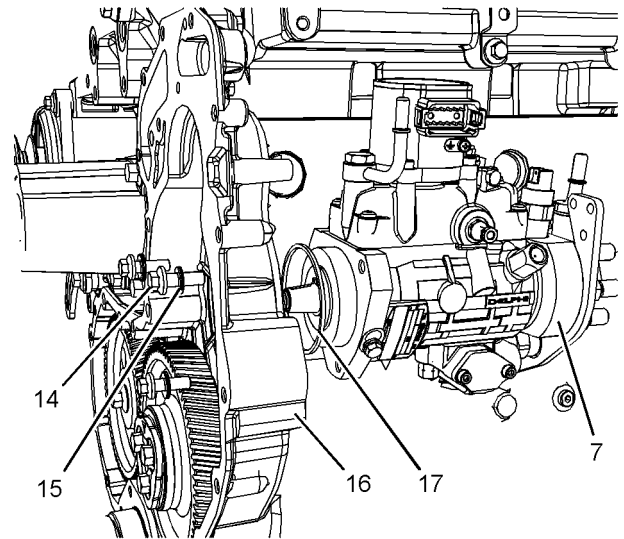

Illustration 27

g02695516

2. Install a new O-ring seal (17) to fuel injection pump (7).
 3. Install new sealing washers (15) to bolts (14).
 4. Carefully install fuel injection pump (7) to front housing (16).
- Note:** The fuel injection pump should be supported by hand as the bolts are installed.
5. Install bolts (14) to fuel injection pump (7) hand tight.
 6. Tighten bolts (14) to a torque of 22 N·m (195 lb in).

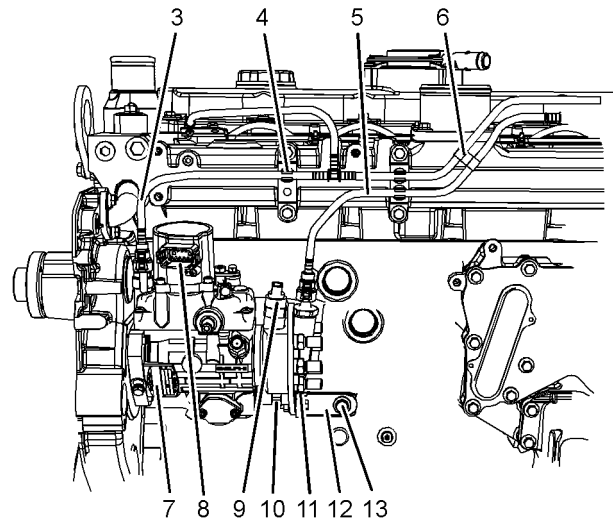

Illustration 28

g02695396

7. Position bracket (12) onto the cylinder block and the fuel injection pump. Install bolt (13) to the cylinder block finger tight.
8. Install the nut and bolt (11) to fuel injection pump (7) finger tight.
9. Tighten bolts (13) to a torque of 44 N·m (32 lb ft). Tighten the nut and bolt (11) to a torque of 22 N·m (195 lb in).

Note: Ensure that the fuel injection pump is not stressed as the bolts for the bracket are tightened.

10. Ensure that the No. 1 cylinder is at top dead center on the compression stroke. Refer to Systems Operation, Testing and Adjusting, "Fuel Injection Timing - Check". If necessary, use Tooling (A) in order to rotate the crankshaft so that number one piston is at the top center position on the compression stroke. Refer to Systems Operation, Testing and Adjusting, "Finding Top Center Position for No.1 Piston" for the correct procedure.

11. Use Tooling (C) in order to lock the camshaft in the correct position. Use Tooling (B) in order to lock the crankshaft in the correct position.

12. Install the fuel injection pump gear to fuel injection pump (7). Refer to Disassembly and Assembly, "Fuel Injection Pump Gear - Install".

13. Remove Tooling (C) and Tooling (B).

14. Install the fuel injection lines. Refer to Disassembly and Assembly, "Fuel Injection Lines - Install" for the correct procedure.

15. Remove the plugs from fuel injection pump (7).

16. Remove the caps from plastic tube assembly (3), and plastic tube assembly (5).

17. Connect plastic tube assembly (3), and plastic tube assembly (5) to fuel injection pump (7).

18. Install plastic tube assembly (3), and plastic tube assembly (5) to clips (4) and clip (6).

19. Connect the OEM harness assembly to governor (8).

20. Connect the OEM harness assemblies to solenoid(9) and solenoid (10).

21. If necessary, connect the OEM harness assemblies to solenoid (10).

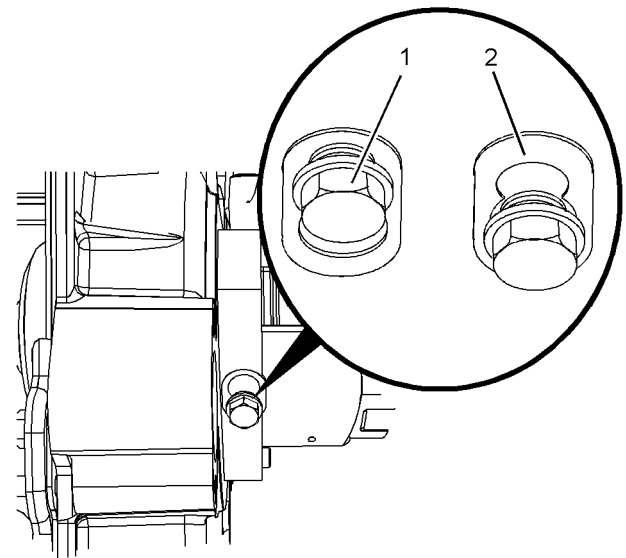

Illustration 29

g02695477

22. Loosen locking screw (1). Rotate spacer (2) in order to allow locking screw (1) to tighten against spacer (2). Tighten locking screw (1) to a torque of 12 N·m (106 lb in).

Note: Ensure that the fuel injection pump is in the unlocked position.

23. Turn the fuel supply to the OFF position.

24. Turn the battery disconnect switch to the ON position.

25. Remove the air from the fuel system. Refer to Operation and Maintenance Manual, "Fuel System - Prime" for the correct procedure.

End By:

- a. Install the front cover. Refer to Disassembly and Assembly, "Front Cover - Remove and Install" for the correct procedure .

i04656192

Fuel Injection Pump - Install (With Boost Control)

Installation Procedure

Table 9

Required Tools			
Tool	Part Number	Part Description	Qty
A ⁽¹⁾	T400011	Crankshaft Turning Tool	1
A ⁽²⁾	27610291	Housing	1
	27610289	Engine Turning Tool	1
B	27610286	Timing Pin (Crankshaft)	1
C	27610212	Timing Pin (Camshaft)	1

(1) The Crankshaft Turning Tool is used on the front pulley.

(2) This Tool is used in the aperture for the electric starting motor.

Note: Either Tooling (A) can be used. Use the Tooling that is most suitable.

NOTICE

Ensure that all adjustments and repairs that are carried out to the fuel system are performed by authorized personnel that have the correct training.

Before beginning ANY work on the fuel system, refer to Operation and Maintenance Manual, "General Hazard Information and High Pressure Fuel Lines" for safety information.

Refer to System Operation, Testing and Adjusting, "Cleanliness of Fuel System Components" for detailed information on the standards of cleanliness that must be observed during ALL work on the fuel system.

1. Inspect the bore in the front housing for damage. If the bore is damaged, replace the front housing. Refer to Disassembly and Assembly, "Housing (Front) - Remove" for the correct procedure.

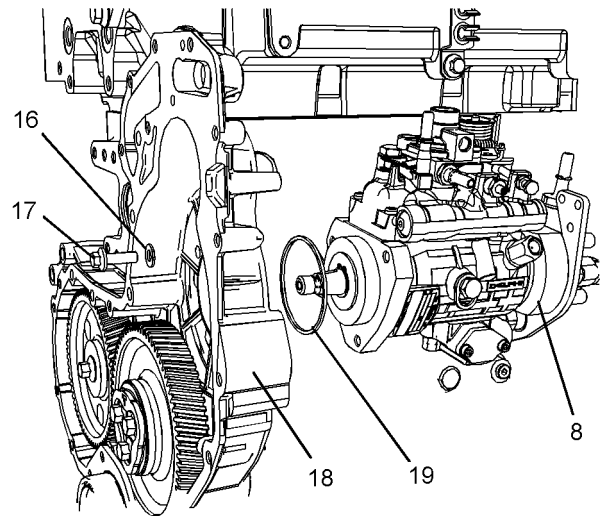

Illustration 30

g02791604

2. Install a new O-ring seal (19) to fuel injection pump (8).
 3. Install new sealing washers (16) to bolts (17).
 4. Carefully install fuel injection pump (8) to front housing (18).
- Note:** The fuel injection pump should be supported by hand as the bolts are installed.
5. Install bolts (17) to fuel injection pump (8) hand tight.
 6. Tighten bolts (17) to a torque of 22 N·m (195 lb in).

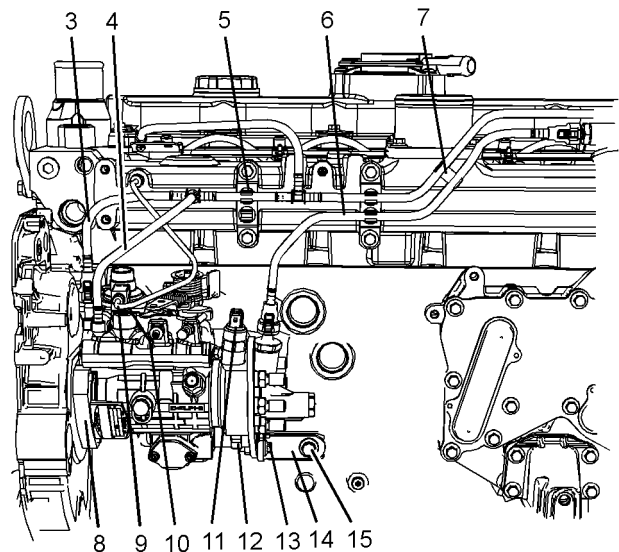

Illustration 31

g02791603

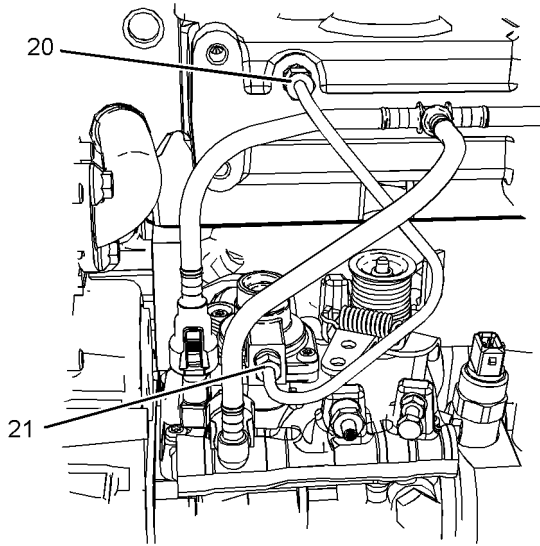

Illustration 32

g02792516

7. Position bracket (14) onto the cylinder block and the fuel injection pump. Install bolt (15) to the cylinder block finger tight.
8. Install the nut and bolt (13) to fuel injection pump (8) finger tight.
9. Tighten bolts (15) to a torque of 44 N·m (32 lb ft). Tighten the nut and bolt (13) to a torque of 22 N·m (195 lb in).

Note: Ensure that the fuel injection pump is not stressed as the bolts for the bracket are tightened.

10. Ensure that the No. 1 cylinder is at top dead center on the compression stroke. Refer to Systems Operation, Testing and Adjusting, "Fuel Injection Timing - Check". If necessary, use Tooling (A) in order to rotate the crankshaft so that number one piston is at the top center position on the compression stroke. Refer to Systems Operation, Testing and Adjusting, "Finding Top Center Position for No.1 Piston" for the correct procedure.
11. Use Tooling (C) in order to lock the camshaft in the correct position. Use Tooling (B) in order to lock the crankshaft in the correct position.
12. Install the fuel injection pump gear to fuel injection pump (8). Refer to Disassembly and Assembly, "Fuel Injection Pump Gear - Install".
13. Remove Tooling (C) and Tooling (B).
14. Install the fuel injection lines. Refer to Disassembly and Assembly, "Fuel Injection Lines - Install" for the correct procedure.

15. Install a new seal (10) (not shown) to tube assembly (9).
16. Connect tube assembly (9) to fuel injection pump (8) and the cylinder head.
17. Tighten tube nut (20) to a torque of 8 N·m (71 lb in).
18. Tighten tube nut (21) to a torque of 6 N·m (53 lb in).
19. Remove the plugs from fuel injection pump (8).
20. Remove the caps from plastic tube assembly (3), plastic tube assembly (4), and plastic tube assembly (6).
21. Connect plastic tube assembly (3), plastic tube assembly (4), and plastic tube assembly (4) to fuel injection pump (8).
22. Install plastic tube assembly (3), plastic tube assembly (5), and plastic tube assembly (6) to clips (5) and clip (7).
23. Connect the OEM harness assemblies to solenoid (11) and solenoid (12).

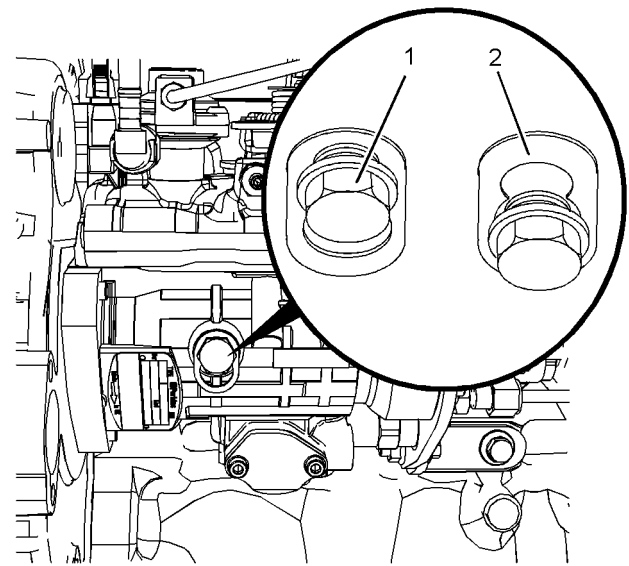

Illustration 33

g02791601

24. Loosen locking screw (1). Rotate spacer (2) in order to allow locking screw (1) to tighten against spacer (2). Tighten locking screw (1) to a torque of 12 N·m (106 lb in).

Note: Ensure that the fuel injection pump is in the unlocked position.

25. Turn the fuel supply to the OFF position.

- 26. Turn the battery disconnect switch to the ON position.
- 27. Remove the air from the fuel system. Refer to Operation and Maintenance Manual, "Fuel System - Prime" for the correct procedure.

End By:

- a. Install the front cover. Refer to Disassembly and Assembly, "Front Cover - Remove and Install" for the correct procedure .

i04473031

Fuel Injection Pump Gear - Remove

Removal Procedure

Table 10

Required Tools			
Tool	Part Number	Part Description	Qty
A ⁽¹⁾	T400011	Crankshaft Turning Tool	1
A ⁽²⁾	27610291	Housing	1
	27610289	Engine Turning Tool	1
B	27610212	Timing Pin (Camshaft)	1
C	27610286	Timing Pin (Crankshaft)	1
D	-	Puller (Three Leg)	1

(1) The Crankshaft Turning Tool is used on the front pulley.
 (2) This Tool is used in the aperture for the electric starting motor.

Start By:

- a. Remove the front cover. Refer to Disassembly and Assembly, "Front Cover - Remove and Install".

Note: Either Tooling (A) can be used. Use the Tooling that is most suitable.

NOTICE

Keep all parts clean from contaminants.

Contaminants may cause rapid wear and shortened component life.

NOTICE

Care must be taken to ensure that fluids are contained during performance of inspection, maintenance, testing, adjusting and repair of the product. Be prepared to collect the fluid with suitable containers before opening any compartment or disassembling any component containing fluids.

Dispose of all fluids according to local regulations and mandates.

Note: Care must be taken in order to ensure that the fuel injection pump timing is not lost during the removal of the fuel pump gear. Carefully follow the procedure in order to remove the fuel pump gear.

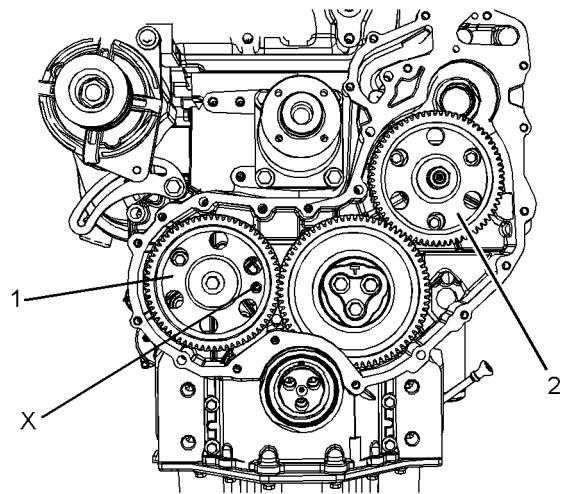

Illustration 34

g02695977

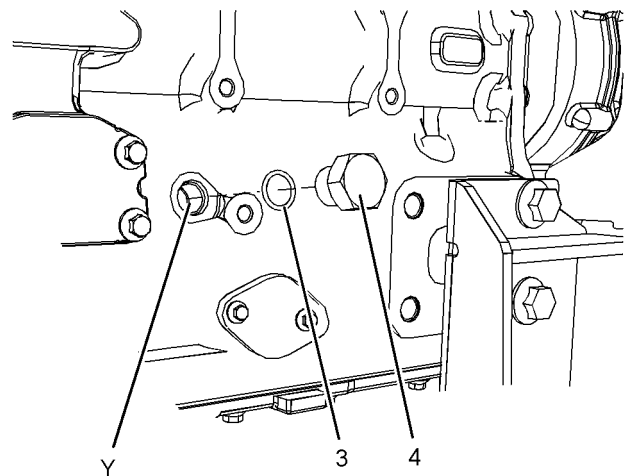

Illustration 35

g02695979

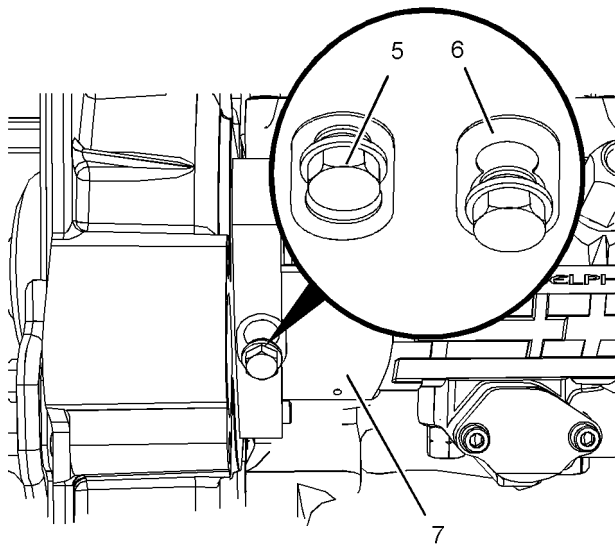

Illustration 36
With Electronic Governor

g02695996

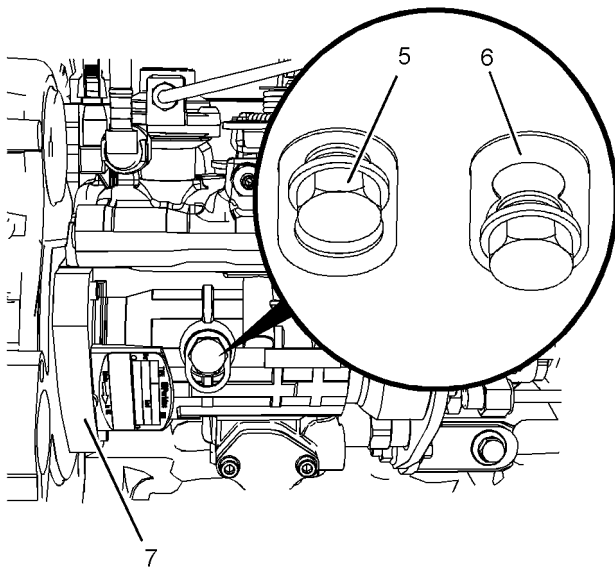

Illustration 37
With Boost Control

g02792627

1. Remove plug (4) from the cylinder block. Remove O-ring seal (3) from plug (4).
2. Use Tooling (A) in order to rotate the crankshaft so that number one piston is at top dead center on the compression stroke. Refer to System Operation, Testing and Adjusting, "Finding Top Center Position for No.1 Piston".
3. Install Tooling (B) through Hole (X) in camshaft gear (1) into the front housing. Use Tooling (B) in order to lock the camshaft in the correct position.

4. Install Tooling (C) into Hole (Y) in the cylinder block. Use Tooling (C) in order to lock the crankshaft in the correct position.

Note: Do not use excessive force to install Tooling (C). Do not use Tooling (C) to hold the crankshaft during repairs.

5. Apply sufficient pressure to fuel injection pump gear (2) in a counterclockwise direction in order to remove the backlash. Lock fuel injection pump (2) in this position.

In order to lock fuel injection pump (7), loosen locking screw (5) in the fuel injection pump. Slide spacer (6) into the locked position. Tighten locking screw (5) against the shaft of the fuel injection pump to a torque of 15 N·m (133 lb in).

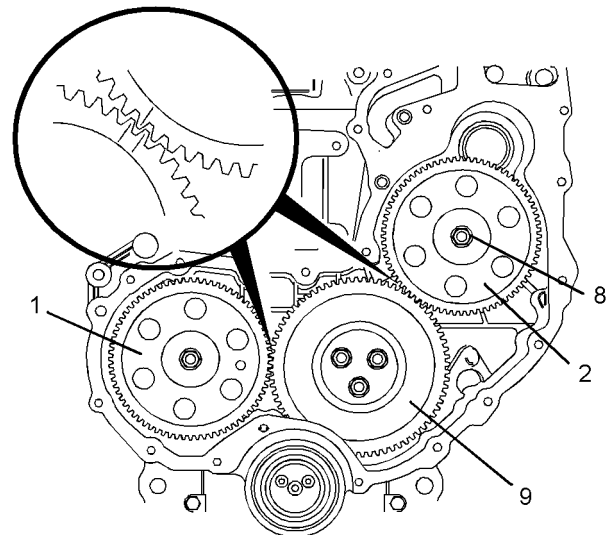

Illustration 38

g02697836

6. Mark gear (1), gear (2) and gear (9) in order to show alignment.

Alignment of timing marks

Note: Identification will ensure that the gears can be installed in the original alignment.

7. Loosen nut (8) for the fuel pump gear.
8. Install Tooling (D) through three holes in gear (2). Tighten Tooling (D) until gear (2) is released.
9. Remove Tooling (D) from gear (2).
10. Remove nut (8) and the washer from fuel pump gear (3). Remove the gear (2).

i04473030

Fuel Injection Pump Gear - Install

Installation Procedure

Table 11

Required Tools			
Tool	Part Number	Part Description	Qty
A ⁽¹⁾	T400011	Crankshaft Turning Tool	1
A ⁽²⁾	27610291	Housing	1
	27610289	Engine Turning Tool	1
B	27610212	Timing Pin (Camshaft)	1
C	27610286	Timing Pin (Crankshaft)	1

(1) The Crankshaft Turning Tool is used on the front pulley.

(2) This Tool is used in the aperture for the electric starting motor.

NOTICE

Keep all parts clean from contaminants.

Contaminants may cause rapid wear and shortened component life.

Note: The fuel injection pump must remain locked until the procedure instructs you to unlock the fuel injection pump.

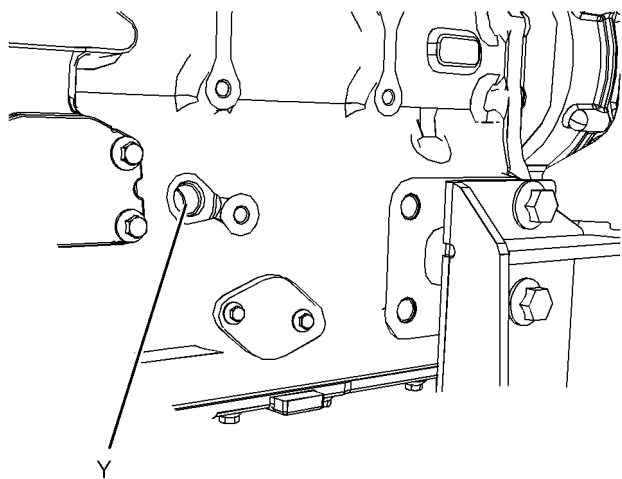

Illustration 39

g02697876

1. If necessary, use Tooling (A) to ensure that number one piston is at top dead center on the compression stroke. Refer to System Operation, Testing and Adjusting, "Finding Top Center Position for No.1 Piston".
2. Ensure that Tooling (C) is installed in Hole (Y) in the cylinder block. Use Tooling (C) in order to lock the crankshaft in the correct position.

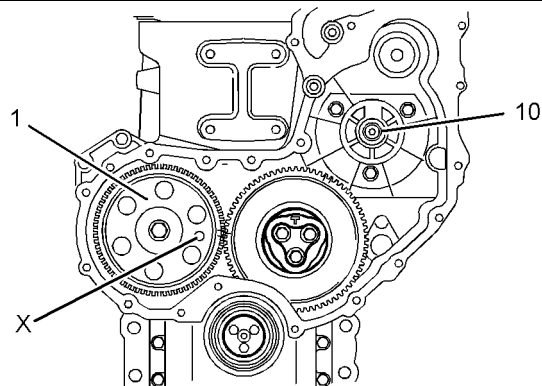

Illustration 40

g02697877

3. Ensure that Tooling (B) is installed into Hole (X) in camshaft gear (1).
4. Ensure that shaft (10) of the fuel injection pump is clean and free from damage.
5. Ensure that the fuel injection pump is locked in the correct position. Refer to Disassembly and Assembly, "Fuel Injection Pump - Install".
6. Ensure that the fuel pump gear is clean and free from wear of damage. If necessary, replace the fuel pump gear.

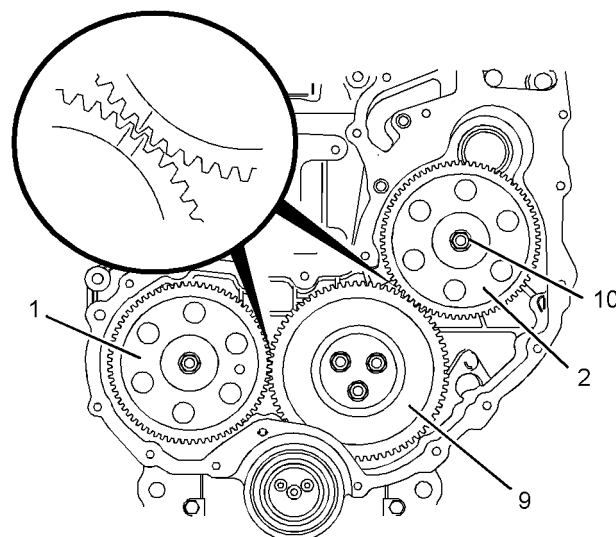

Illustration 41

g02698099

7. Install fuel pump gear (2) to shaft (10) of the fuel injection pump. Ensure that the timing marks on gear (1), gear (2), and gear (9) are in alignment and that the mesh of the gears is correct.

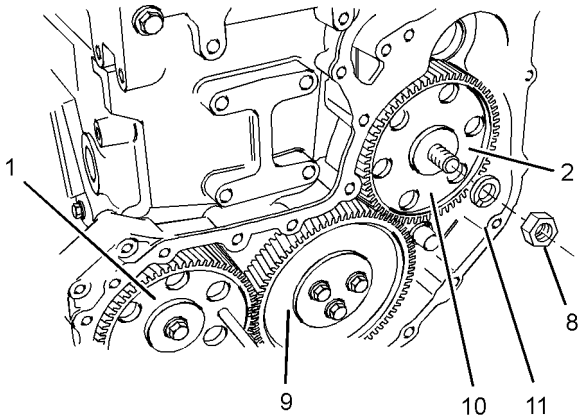

Illustration 42

g02698100

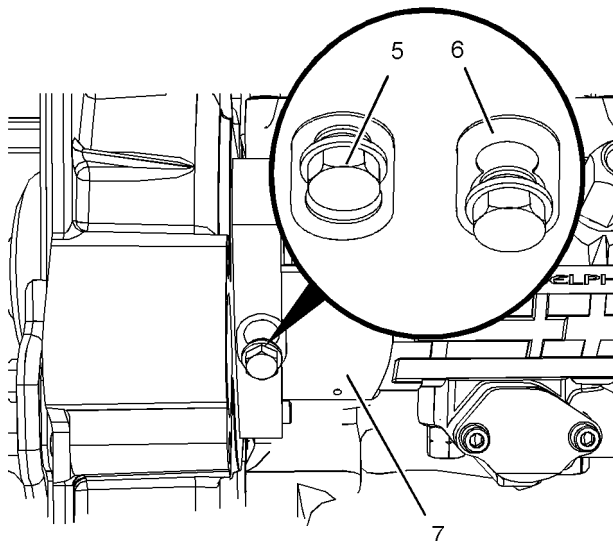

Illustration 43

g02695996

With Electronic Governor

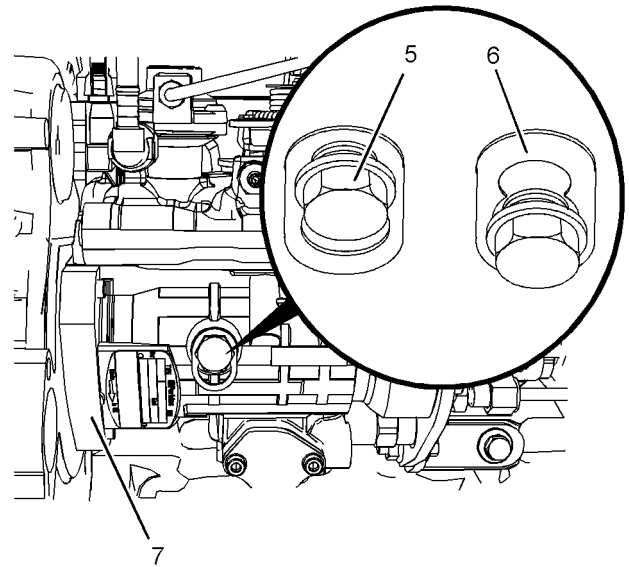

Illustration 44

g02792627

With Boost Control

8. Install a new spring washer (11) and install nut (8) to shaft (10) of the fuel injection pump. Apply sufficient pressure to fuel injection pump gear (2) in a counterclockwise direction in order to remove the backlash. Tighten nut (8) to a torque of 24 N·m (212 lb in).
9. In order to unlock fuel injection pump (7), loosen locking bolt (5) in the fuel injection pump. Slide spacer (6) into unlock position. Tighten locking bolt (5) against the spacer to a torque of 12 N·m (106 lb in). The spacer will prevent the locking bolt from tightening against the shaft of the fuel injection pump.
10. Remove Tooling (B) and Tooling (C).
11. Tighten nut (8) to a torque of 90 N·m (66 lb ft).
12. Ensure that the backlash for gear (1), gear (2) and gear (9) is within specified values. Refer to the Specifications, "Gear Group (Front)" for further information.

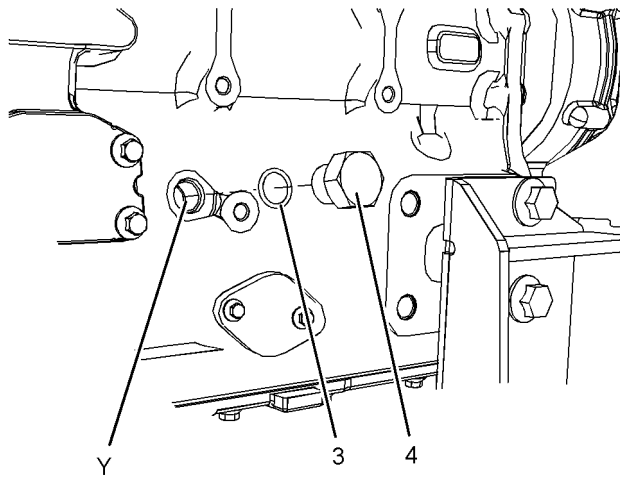

Illustration 45

g02695979

13. Install a new O-ring seal (3) to plug (4). Install plug (4) to the cylinder block. Tighten plug (4) to a torque of 21 N·m (186 lb in).

14. Lubricate the teeth of the gears with clean engine oil.

End By:

- a. Install the front cover. Refer to Disassembly and Assembly, "Front Cover - Remove and Install".

i04473049

Fuel Injector - Remove

Removal Procedure

Table 12

Required Tools			
Tool	Part Number	Part Description	Qty
A	-	Laser 4044 Fuel Injector Puller	1
B	T400106	Capping Kit	

Start By:

- a. Remove the fuel injection lines. Refer to Disassembly and Assembly, "Fuel Injection Lines - Remove".

NOTICE

Keep all parts clean from contaminants.

Contaminants may cause rapid wear and shortened component life.

NOTICE

Care must be taken to ensure that fluids are contained during performance of inspection, maintenance, testing, adjusting and repair of the product. Be prepared to collect the fluid with suitable containers before opening any compartment or disassembling any component containing fluids.

Dispose of all fluids according to local regulations and mandates.

Note: Put identification marks on all tube assemblies for installation purposes. Plug all plastic tube assemblies and tube assemblies. Plugging tube assemblies will prevent fluid loss and will keep contaminants from entering the system.

1. Turn the fuel supply to the OFF position.
2. Turn the battery disconnect switch to the OFF position.

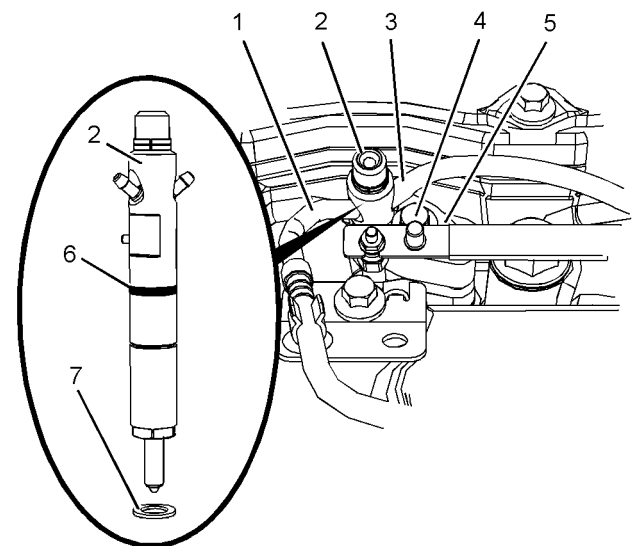

Illustration 46

g02699460

3. Remove hose assembly (1) and hose assembly (3) from fuel injector (2).
4. Use Tooling (B) to plug fuel injector (2).
5. Use Tooling (B) to cap hose assembly (1) and hose assembly (3).
6. Remove bolt (4). Remove clamp (5) from fuel injector (2).

7. Use Tooling (A) in order to remove fuel injector (2) from the cylinder head. Remove O-ring seal (6) from fuel injector (2).
8. Remove seat washer (7).
9. If necessary, repeat Step 3 through Step 8 in order to remove the remaining fuel injectors.

i04473032

Fuel Injector - Install

Installation Procedure

NOTICE

Keep all parts clean from contaminants.

Contaminants may cause rapid wear and shortened component life.

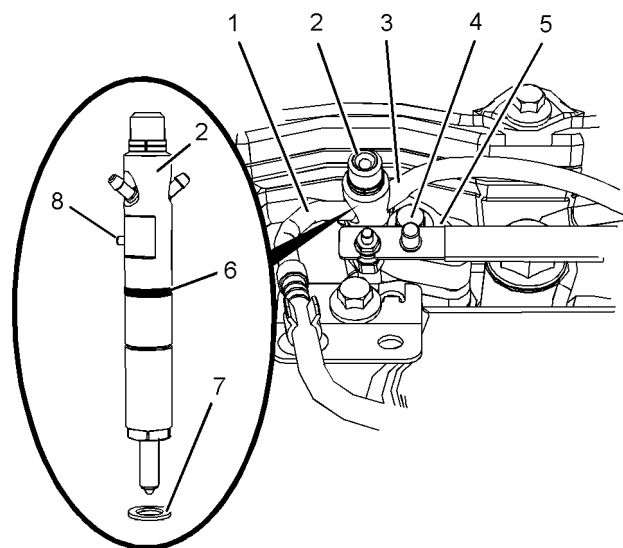

Illustration 47

g02699476

1. Ensure that the seat for the fuel injector in the cylinder head and the fuel injector is clean and free from damage.
2. Install a new sealing washer (7) on the seat for fuel injector (2).
3. Install a new O-ring seal (6) on fuel injector (2).
4. Position clamp (5) onto fuel injector (2). Install fuel injector (2) into the cylinder head.

Note: Alignment Pin (8) must be located opposite clamp (5).

5. Install bolt (4) finger tight.

6. Tighten bolt (4) to a torque of 27 N·m (239 lb in).
7. Remove plugs from hose assembly (1) and hose assembly (3). Remove cap from fuel injector (2).
8. Install hose assembly (1) and hose assembly (3) to fuel injector (2).
9. If necessary, repeat Step 11 through Step 7 in order to install the remaining fuel injector.
10. Turn the fuel supply to the ON position.
11. Turn the battery disconnect switch to the ON position.

End By:

- a. Install the fuel injection lines. Refer to Disassembly and Assembly, "Fuel Injection Lines - Install".

i04647253

Turbocharger - Remove (Turbocharger Top Mounted)

Removal Procedure

NOTICE

Keep all parts clean from contaminants.

Contaminants may cause rapid wear and shortened component life.

NOTICE

Care must be taken to ensure that fluids are contained during performance of inspection, maintenance, testing, adjusting and repair of the product. Be prepared to collect the fluid with suitable containers before opening any compartment or disassembling any component containing fluids.

Dispose of all fluids according to local regulations and mandates.

Note: Plug and cap all open ports and tube assemblies.

1. Loosen the hose clamps and disconnect the hose assembly from the turbocharger inlet.
2. Loosen the hose clamps and disconnect the hose assembly from the turbocharger outlet.
3. If necessary, remove the hose assembly from the wastegate actuator on the turbocharger.

4. Remove the exhaust out tube assembly from the turbocharger, refer to the Original Equipment Manufactures (OEM) for the correct procedure.
5. If necessary, remove the exhaust elbow. Refer to Disassembly and Assembly, "Exhaust Elbow - Remove and Install" for the correct procedure.

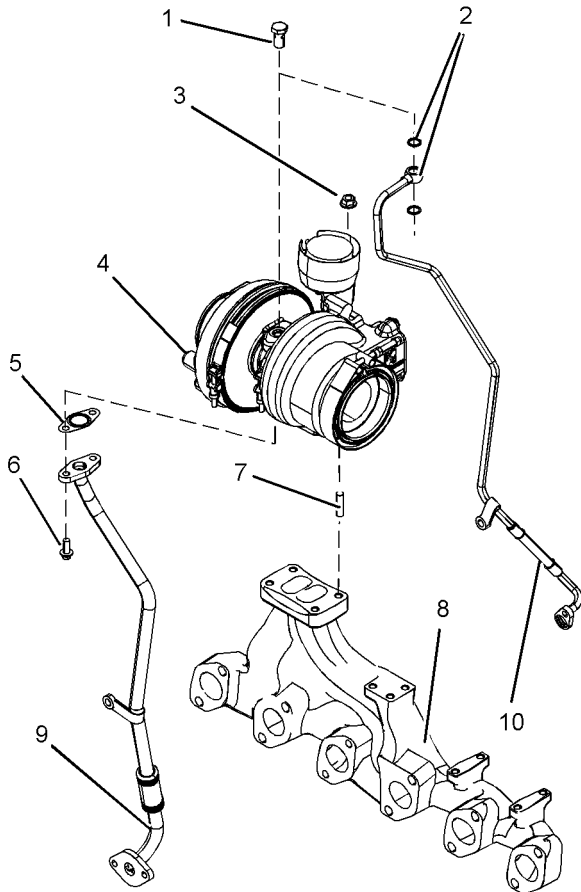

Illustration 48
Typical example

g02790856

6. Remove banjo bolt (1) and remove sealing washers (2) from tube assembly (10).
7. Remove bolts (6) from tube assembly (9). Remove gasket (5).
8. Remove the tube clamps from tube assembly (9) and tube assembly (10). Position tube assembly (10) away from turbocharger (4).
9. Remove nuts (3) from turbocharger (4).
10. Remove turbocharger (4) from exhaust manifold (8).
11. If necessary, remove studs (7) from exhaust manifold (8).

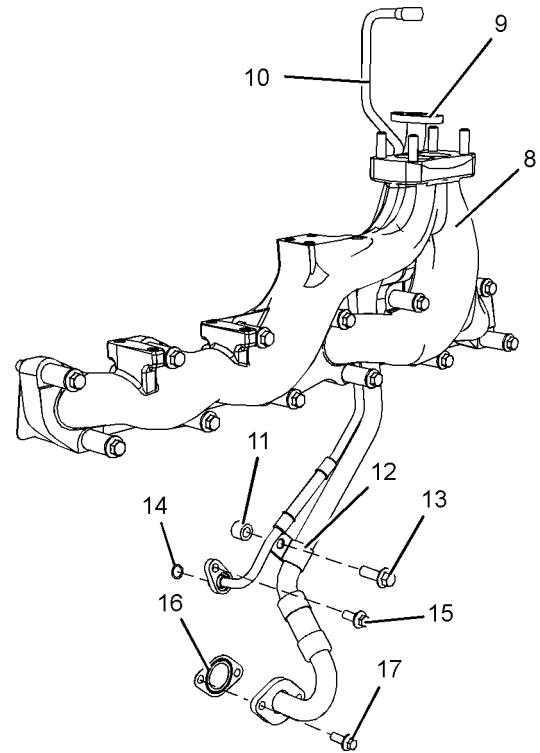

Illustration 49
Typical example

g02790880

12. In order to remove tube assembly (9) and tube assembly (10) the removal of exhaust manifold (8) will be necessary.
13. Remove bolt (13) from tube clips (12) and remove spacer (11).
14. Remove bolt (15) from tube assembly (10). Disconnect tube assembly (10) from the cylinder block.
15. Remove bolts (17) from tube assembly (9). Remove gasket (16).
16. Remove exhaust manifold. Refer to Disassembly and Assembly, "Exhaust Manifold (Top Mounted Turbo Charger Exhaust Manifold) - Remove and Install" for the correct procedure.
17. Remove tube assembly (9) and tube assembly (10). Remove O-ring seal (14) from tube assembly (10).

i04473093

Turbocharger - Remove (Side Mounted Turbocharger)

Removal Procedure

NOTICE

Keep all parts clean from contaminants.

Contaminants may cause rapid wear and shortened component life.

NOTICE

Care must be taken to ensure that fluids are contained during performance of inspection, maintenance, testing, adjusting and repair of the product. Be prepared to collect the fluid with suitable containers before opening any compartment or disassembling any component containing fluids.

Dispose of all fluids according to local regulations and mandates.

Note: Plug and cap all open ports and tube assemblies.

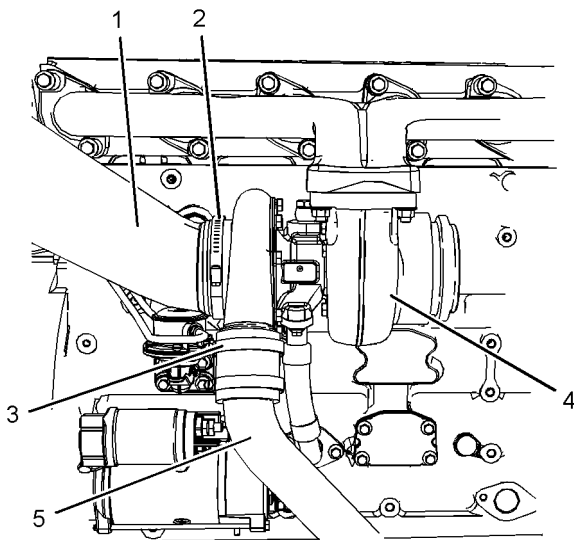

Illustration 50

g02719460

1. Loosen hose clamp (2) and disconnect hose assembly (1) from turbocharger (4).
2. Loosen hose clamp (3) and disconnect tube assembly (5) from turbocharger (4).
3. If necessary, remove the hose assembly from the wastegate actuator on the turbocharger.

4. Remove the exhaust out tube assembly from the turbocharger, refer to the Original Equipment Manufactures (OEM) for the correct procedure.
5. If necessary, remove the exhaust elbow. Refer to Disassembly and Assembly, "Exhaust Elbow - Remove and Install" for the correct procedure.

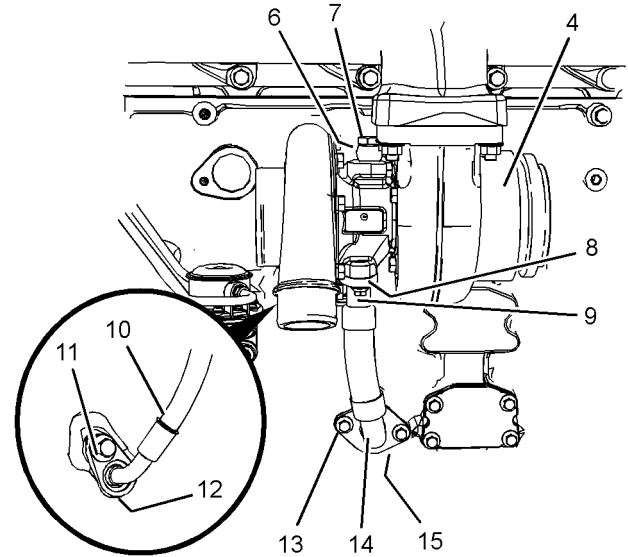

Illustration 51

g02719476

6. Remove banjo bolt (7) from tube assembly (10). Remove sealing washers (6) (not shown).
7. Remove bolt (11) from tube assembly (10). Remove tube assembly (10) from turbocharger (4) and the cylinder block.
8. Remove O-ring seal (12) (not shown) from tube assembly (10).
9. Remove bolts (9) from tube assembly (14). Remove bolts (13) from tube assembly (14).
10. Remove tube assembly (14) from turbocharger (4) and the cylinder block.
11. Remove gasket (8) (not shown) and gasket (15) (not shown).

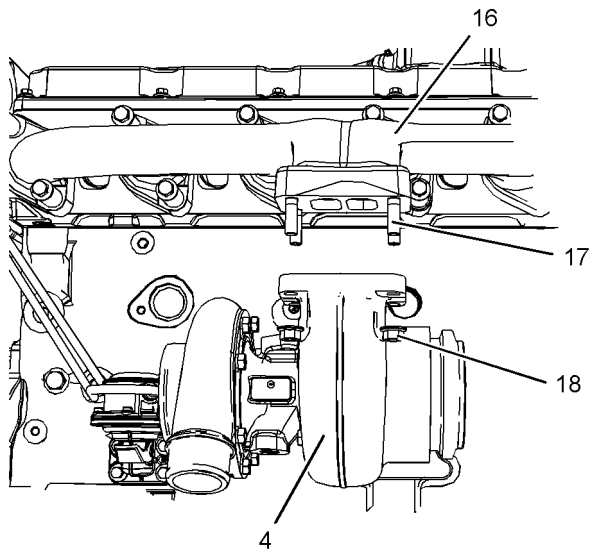

Illustration 52

g02719461

12. Remove nuts (18) from turbocharger (4). Remove turbocharger (4) from exhaust manifold (16).

Note: Ensure that the weight of the turbocharger is supported as the nuts are removed.

13. If necessary, remove studs (17) from exhaust manifold (16).

i04473092

Turbocharger - Install (Side Mounted Turbocharger)

Installation Procedure

Table 13

Required Tools			
Tool	Part Number	Part Description	Qty
A	-	Delphi Lockheed Rubber Grease	1

NOTICE

Keep all parts clean from contaminants.

Contaminants may cause rapid wear and shortened component life.

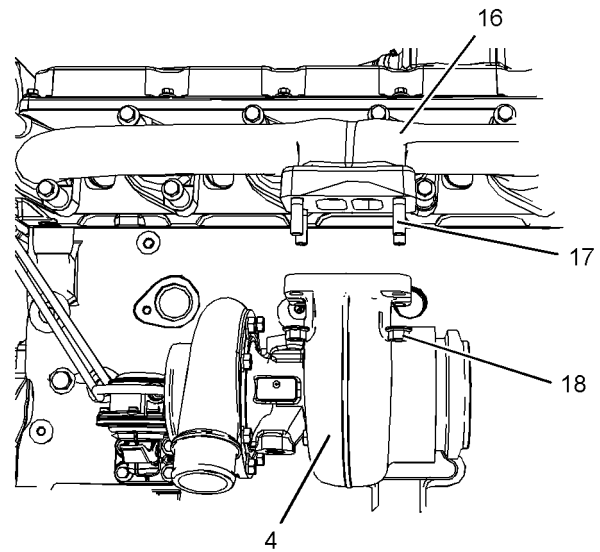

Illustration 53

g02719461

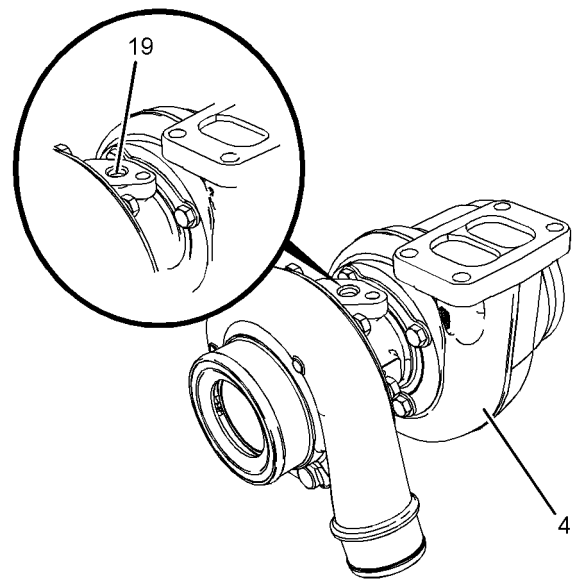

Illustration 54

g02719579

1. Ensure that turbocharger (4) is clean and free from damage. Inspect the turbocharger for wear. Refer to System Operation, Testing and Adjusting, "Turbocharger Inspect" for more information. If any part of the turbocharger is worn or damaged, the complete turbocharger must be replaced.
2. If necessary, test the wastegate actuator for correct operation. Refer to System Operation, Testing and Adjusting, "Turbocharger Inspect". If the wastegate actuator is damaged or the wastegate actuator does not operate within the specified limits, the complete turbocharger must be replaced.

3. Clean the gasket surfaces of exhaust manifold (16). If necessary, install studs (17) to the exhaust manifold. Tighten the studs to a torque of 18 N·m (160 lb in).

4. Position turbocharger (4) on exhaust manifold (16).

Note: Ensure that the turbocharger is correctly oriented.

5. Install nuts (18).

Note: Support the turbocharger as the nuts are installed.

6. Tighten nuts (18) to a torque of 44 N·m (32 lb ft).

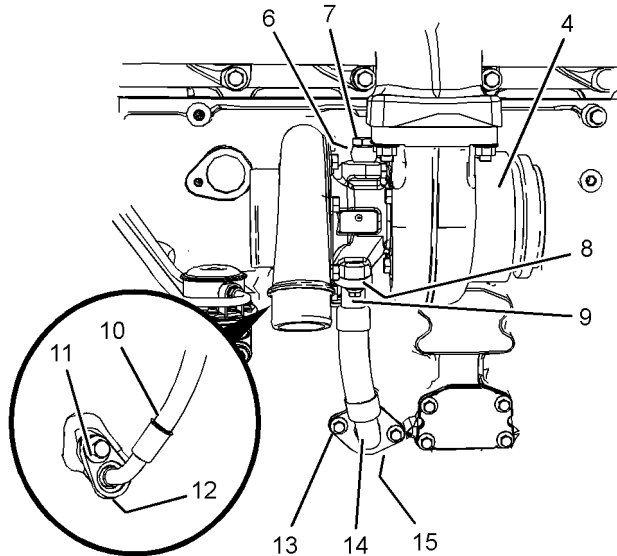

Illustration 55

g02719476

7. Ensure that tube assembly (14) and tube assembly (10) are clean, free from damage and restriction. Replace any damaged components.

8. Position a new gasket (8) (not shown) and bolts (9) onto tube assembly (14).

9. Install tube assembly (14) to turbocharger (4). Install bolts (9) finger tight.

10. Position a new gasket (15) (not shown) between the flange of tube assembly (10) and the cylinder block. Install bolts (13) finger tight.

11. Tighten bolts (9) and bolts (13) to a torque of 22 N·m (195 lb in).

12. Remove the plug from oil inlet port (19). Refer to Illustration 54. Lubricate the turbocharger bearings with clean engine oil through the oil inlet port. Rotate the wheel of the compressor several times in order to lubricate the bearings.

13. Use Tooling (A) in order to lubricate a new O-ring seal (12) (not shown). Install O-ring seal (12) (not shown) to tube assembly (10).

14. Install tube assembly (10) to the cylinder block and position onto turbocharger (4).

15. Install bolt (11) finger tight. Ensure that tube assembly (10) installed correctly into the cylinder block.

16. Install banjo bolt (7) and two new sealing washers (6) (not shown) to tube assembly (10).

17. Tighten banjo bolt (7) to a torque of 20 N·m (177 lb in).

18. Tighten bolt (11) to a torque of 22 N·m (195 lb in).

19. If necessary, install the exhaust elbow. Refer to Disassembly and Assembly, "Exhaust Elbow - Remove and Install" for the correct procedure.

20. Connect the exhaust outlet tube assembly from the turbocharger, refer to the Original Equipment Manufactures (OEM) for the correct procedure.

21. If necessary, install the hose assembly to the wastegate actuator on the turbocharger.

22. Connect tube assembly (5) to turbocharger (4). Tighten hose clamp (3) securely.

23. Connect hose assembly (1) to turbocharger (4). Tighten hose clamp (2) securely.

i04647254

Turbocharger - Install (Turbocharger Top Mounted)

Installation Procedure

Table 14

Required Tools			
Tool	Part Number	Part Description	Qty
A	-	Delphi Lockheed Rubber Grease	1

NOTICE

Keep all parts clean from contaminants.

Contaminants may cause rapid wear and shortened component life.

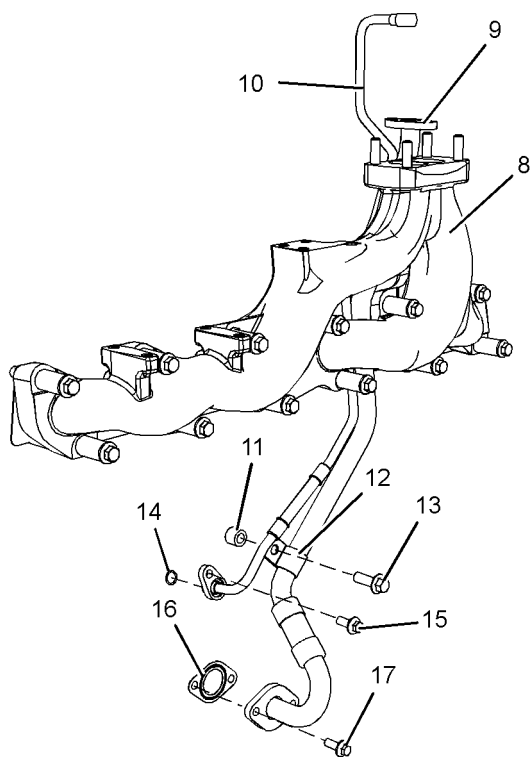

Illustration 56
Typical example

1. Loosely position tube assembly (9) and tube assembly (10) onto the cylinder block prior to the installation of exhaust manifold (8).
2. Follow Step 2.a through Step 2.e in order to install tube assembly (9) and tube assembly (10).
 - a. Ensure that tube assembly (9) and tube assembly (10) are clean and free from damage. Replace any damaged components.
 - b. Use Tooling (A) in order to lubricate a new O-ring seal (14). Install O-ring seal (14) to tube assembly (10).
 - c. Position tube assembly (10) onto the cylinder block. Ensuring that tube assembly (10) is correctly positioned into the cylinder block. Install bolt (15) finger tight.
 - d. Position a new gasket (16) onto tube assembly (9). Position tube assembly (9) onto the cylinder block and install bolts (17) finger tight.
 - e. Install spacer (11) between the clip (12) and the cylinder block. Install bolt (13) finger tight.
3. Install exhaust manifold. Refer to Disassembly and Assembly, "Exhaust Manifold (Top Mounted Turbo Charger Exhaust Manifold) - Remove and Install" for the correct procedure.

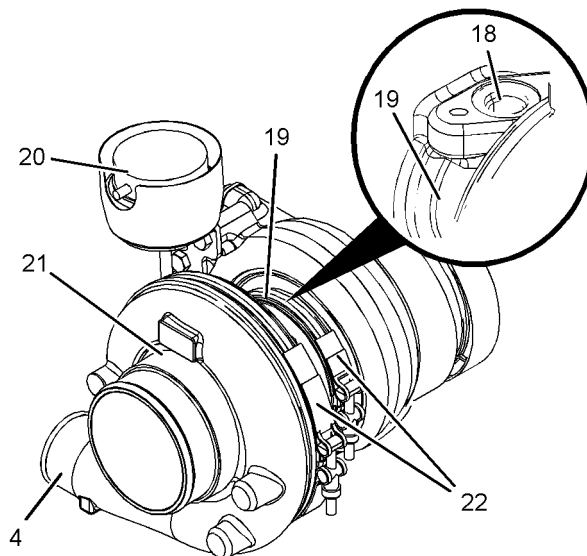

Illustration 57
Typical example

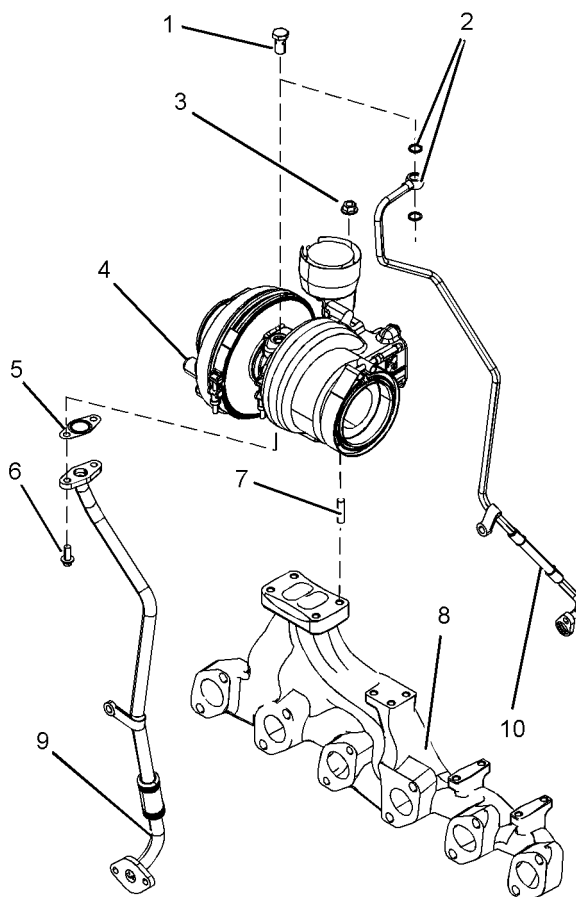

Illustration 58
Typical example

4. Clean the gasket surfaces of exhaust manifold (8). If necessary, install studs (7) to the exhaust manifold. Tighten the studs to a torque of 18 N·m (13 lb ft).
 5. Ensure that turbocharger (4) is clean and free from damage. Inspect the turbocharger for wear. Refer to System Operation, Testing and Adjusting, "Turbocharger Inspect" for more information. If the turbocharger is worn, the complete turbocharger must be replaced.
 6. If necessary, test wastegate actuator (20) for correct operation. Refer to System Operation, Testing and Adjusting, "Turbocharger Inspect". If the wastegate actuator, is damaged or the wastegate actuator does not operate within the specified limits. If the wastegate actuator, is worn or does not operate within the specified limits the complete turbocharger must be replaced.
 7. If a new turbocharger (4) is to be installed, bearing housing (19) and compressor housing (21) must be oriented to the correct positions. Follow Step 7.a through Step 7.d in order to orient the bearing housing and the compressor housing.
 - a. Loosen band clamps (22) sufficiently in order to allow the housings to rotate.
- Note:** If the band clamps are damaged, replace the band clamps.
- b. Carefully turn bearing housing (9) until the port for oil feed (18) is upward position and aligns with tube assembly (9).
 - c. Rotate compressor housing (21) until the compressor outlet is in the correct position. Refer to the turbocharger that was originally installed for the correct orientation.
 - d. Ensure that band clamps (22) are correctly oriented. Refer to the turbocharger that was originally installed for the correct orientation. Tighten the band clamps finger tight.
8. Position turbocharger (4) on exhaust manifold (8).
- Note:** Ensure that the turbocharger is correctly oriented.
9. Install nuts (3). Tighten the nuts to a torque of 44 N·m (32 lb ft).
 10. Position a new gasket (5) between tube assembly (9) and the turbocharger.
 11. Install bolts (6) and tighten the bolts finger tight.
 12. Remove the plug from oil inlet port (18). Refer to Illustration 57. Lubricate the turbocharger bearings with clean engine oil through the oil inlet port. Rotate the wheel of the compressor several times in order to lubricate the bearings.
 13. Install new sealing washer (2) onto banjo bolt (1). Install banjo bolt (1) to tube assembly (10) and install remaining new sealing washer (2). Tighten the banjo bolt finger tight.
 14. Install the tube clamps onto tube assembly (9) and tube assembly (10). Ensure that the tube clamps are installed in the original positions and are correctly positioned.
 15. If a new turbocharger has been installed, check that the orientation of bearing housing (19) is correct. Tighten band clamps (22) to a torque of 13 N·m (115 lb in).
 16. Tighten banjo bolt (1) to a torque of 20 N·m (177 lb in).
 17. Tighten bolts (6) to a torque of 22 N·m (195 lb in).
 18. Tighten bolts (17) and bolt (15) to a torque of 22 N·m (195 lb in). Refer to Illustration 56
 19. Tighten bolt (13) to a torque of 44 N·m (32 lb ft).
 20. If necessary, install the exhaust elbow. Refer to Disassembly and Assembly, "Exhaust Elbow - Remove and Install" for the correct procedure.
 21. Connect the exhaust outlet tube assembly from the turbocharger, refer to the Original Equipment Manufactures (OEM) for the correct procedure.
 22. If necessary, install the hose assembly to the wastegate actuator on the turbocharger.
 23. Connect the hose assembly to the turbocharger inlet. Tighten the hose clamps securely.
 24. Connect the hose assembly to the turbocharger outlet. Tighten the hose clamps securely.

i04647251

Exhaust Manifold - Remove and Install (Top Mounted Exhaust Manifold)

Removal Procedure

1. Remove the turbocharger from the exhaust manifold. Refer to Disassembly and Assembly, "Turbocharger - Remove".

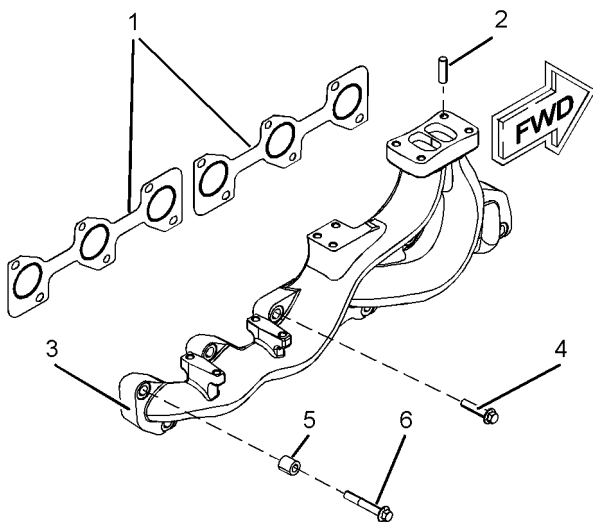

Illustration 59

g01335809

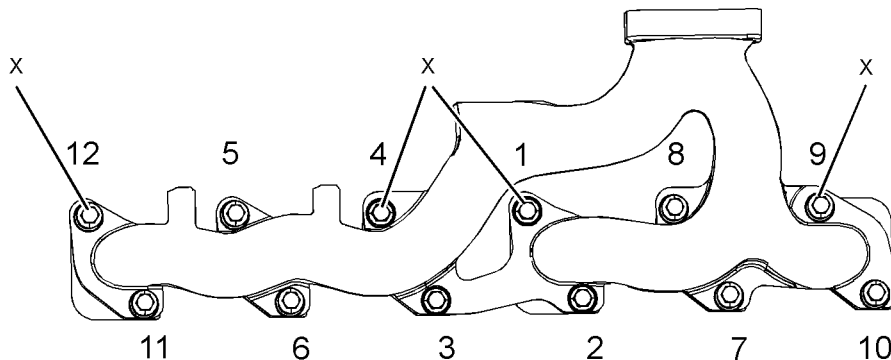

Illustration 60

g01335810

2. Loosen bolts (4) and bolts (6) in reverse numerical order. Refer to Illustration 60.

Note: Loosening bolts in reverse numerical order will help prevent distortion of the exhaust manifold.

3. Remove center bolts (4) from exhaust manifold (3). Remove outer bolts (6) and spacers (5) from exhaust manifold (3).

Note: Support the manifold as the bolts are removed.

4. Remove the assembly of exhaust manifold (3).

5. Remove exhaust manifold gaskets (1).
6. If necessary, remove studs (2) from exhaust manifold (3).

Installation Procedure

Table 15

Required Tools			
Tool	Part Number	Part Description	Qty
A	-	Guide Stud (M10 by 100 mm)	4
B	-	Loctite 575	1

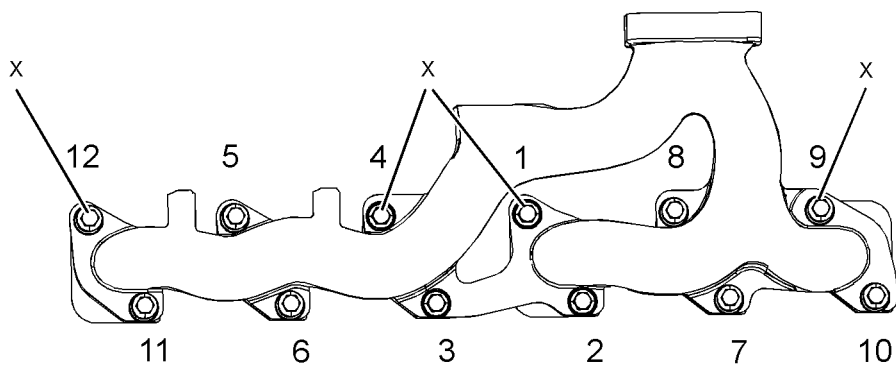

Illustration 61

g01335810

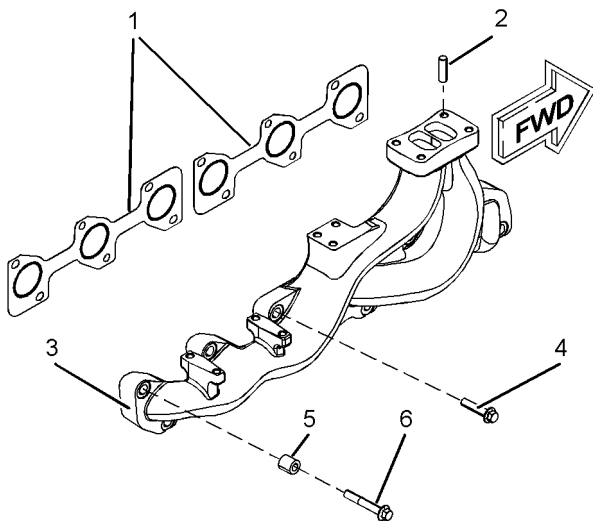

Illustration 62

g01335809

1. Ensure that the exhaust manifold is clean and free from damage. If necessary, replace the exhaust manifold. Clean the gasket surface of the cylinder head.

2. If necessary, install studs (2) to exhaust manifold (3). Tighten the studs to a torque of 18 N·m (159 lb in).
 3. Install Tooling (A) to the cylinder head in Positions (X). Refer to Illustration 61.
 4. Position two new exhaust manifold gaskets (1) onto Tooling (A).
- Note:** Ensure that the word TOP is outward and upward.
5. Align exhaust manifold (3) with Tooling (A). Install the exhaust manifold to the cylinder head.
 6. If bolts (4) and bolts (6) have been previously used, the bolts should be cleaned thoroughly. Tooling (B) should be applied to the first two threads of the bolts.

Note: Do not apply Tooling (B) to new bolts.

7. Install bolts (4) finger tight. Install bolts (6) and spacers (5) finger tight.
8. Remove Tooling (A). Install remaining bolts (4) finger tight. Install remaining bolts (6) and spacers (5) finger tight.

9. Tighten bolts (4) and bolts (6) to a torque of 44 N·m (32 lb ft). Tighten the bolts in the sequence that is shown in Illustration 61.
10. Install the turbocharger to the exhaust manifold. Refer to Disassembly and Assembly, "Turbocharger - Install"4.

i04472993

Exhaust Manifold - Remove and Install (Side Mounted Turbocharger Exhaust Manifold)

Removal Procedure

Start By:

- a. Remove the turbocharger. Refer to Disassembly and Assembly, "Turbocharger - Remove" for the correct procedure.

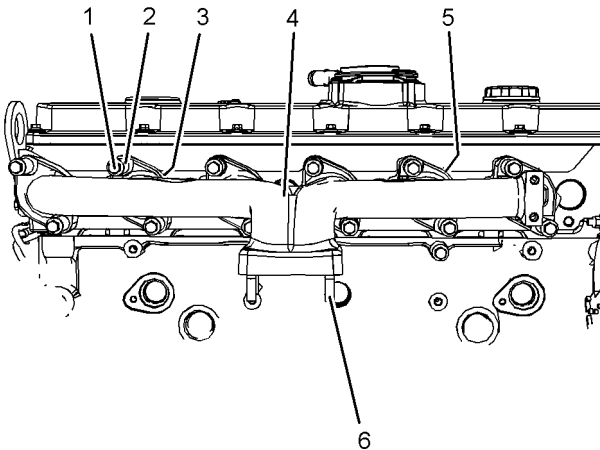

Illustration 63

g02699657

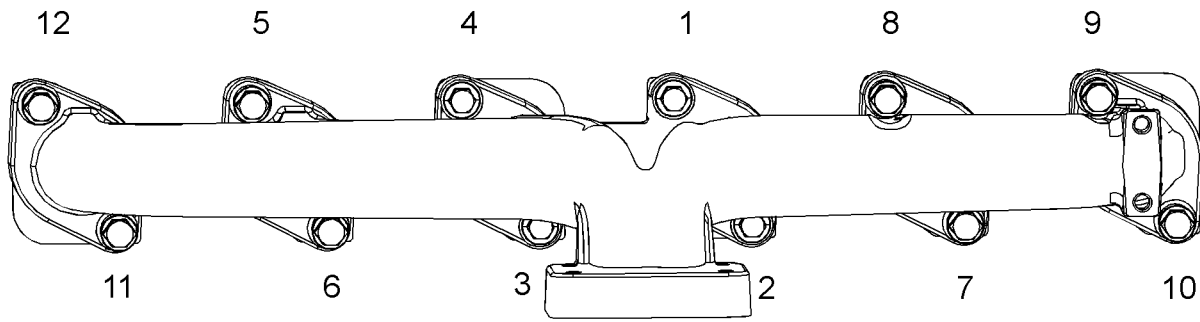

Illustration 64

g02699661

1. Loosen bolts (1) in reverse numerical order. Refer to Illustration 64.

Note: Loosen the bolts in reverse numerical order will help prevent distortion of the exhaust manifold.

2. Remove bolts (1) and spacers (2) from exhaust manifold (4).

Note: Support the manifold as the bolts are removed.

3. Remove exhaust manifold (4).
4. Remove exhaust manifold gasket (3) (not shown) and gasket (5) (not shown).
5. If necessary, remove studs (6) from exhaust manifold (4).

Installation Procedure

Table 16

Required Tools			
Tool	Part Number	Part Description	Qty
A	-	Guide Stud (M10 by 100 mm)	4
B	-	Loctite 575	1

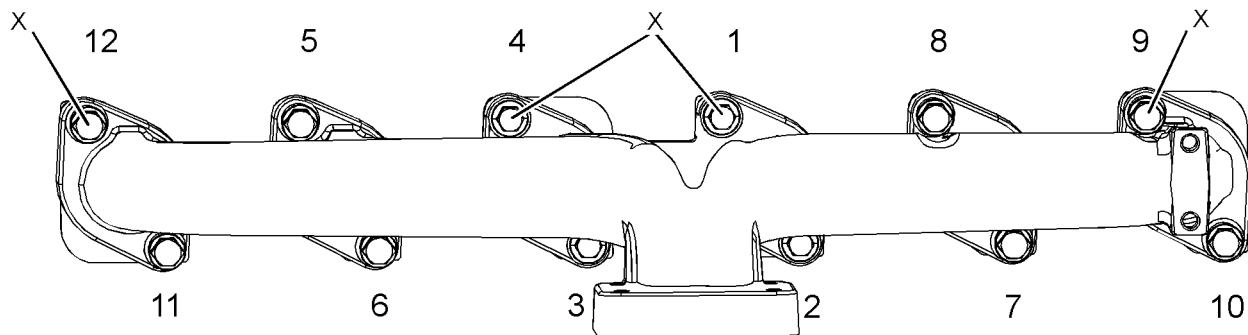

Illustration 65

g02699676

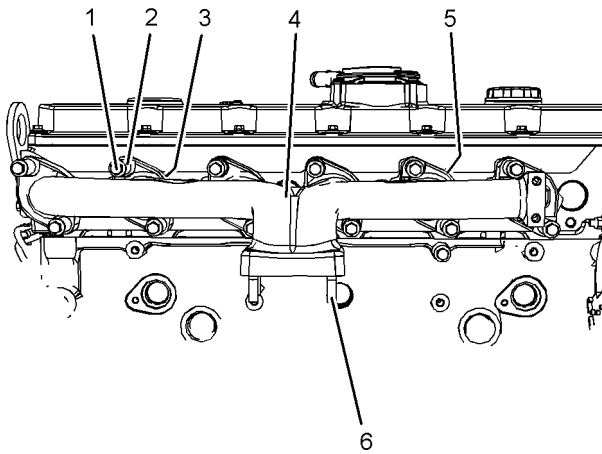

Illustration 66

g02699657

1. Ensure that the exhaust manifold is clean and free from damage. If necessary, replace the exhaust manifold. Clean the gasket face of the cylinder head.
2. If necessary, install studs (6) to exhaust manifold (4). Tighten the studs to a torque of 18 N·m (159 lb in).
3. Install Tooling (A) to the cylinder head in Positions (X). Refer to Illustration 65.
4. Position new gasket (3) (not shown) and gasket (5) (not shown) onto Tooling (A).

Note: Ensure that the words “Cylinder Head Side” is facing to wards the cylinder head.

5. Align exhaust manifold (4) with Tooling (A). Install the exhaust manifold to the cylinder head.
6. If bolts (1) have been previously used. Clean and inspect bolts (1). Apply Tooling (B) to the first two threads of the bolts.

Note: Do not apply Tooling (B) to new bolts.

7. Install bolts (1) and spacers (2) hand tight.
8. Remove Tooling (A). Install remaining bolts (1) and spacers (2) hand tight.
9. Tighten bolts (1) to a torque of 44 N·m (32 lb ft). Tighten the bolts in the sequence that is shown in Illustration 65.

End By:

- a. Install the turbocharger. Refer to Disassembly and Assembly, “Turbocharger - Install” for the correct procedure.

i04472992

Exhaust Elbow - Remove and Install

Removal Procedure

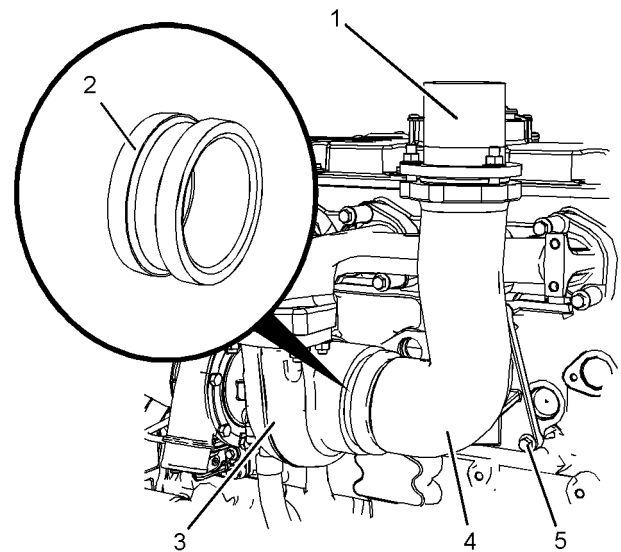

Illustration 67

g02699557

1. Remove exhaust tube assembly (1) from exhaust elbow (4). Refer to the Original Equipment Manufactures (OEM) for the correct removal procedure.
 2. Remove bolts (5) from exhaust elbow (4).
- Note:** Support the exhaust elbow as the bolts are removed.
3. Remove exhaust elbow (4) from the engine.
 4. Remove coupling (2) that connects exhaust elbow (4) to turbocharger (3).

Installation Procedure

i04473058

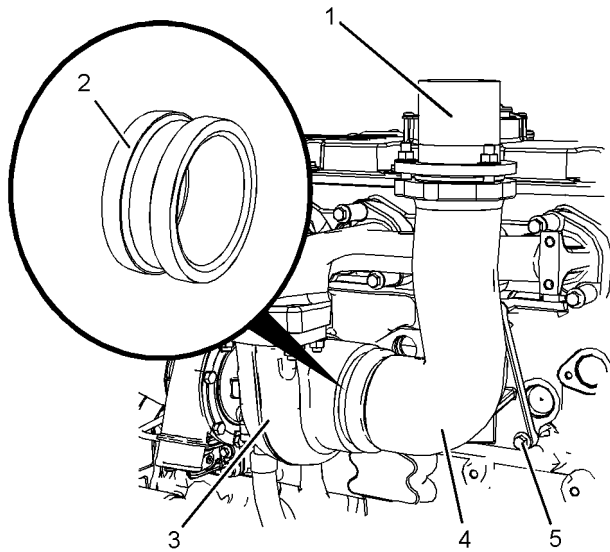

Illustration 68

g02699557

1. Thoroughly clean exhaust elbow (4), coupling (1) and outlet of turbocharger (3). Inspect the sealing faces of the components for wear or damage. Replace any components that are worn or damaged.
2. Install coupling (2) to exhaust elbow (4).
3. Align coupling (2) to the outlet of turbocharger (3). Install assembly of coupling (1) and exhaust elbow (4) to turbocharger (3).
4. Install new bolts (5) hand tight.
5. Ensure that coupling (2) is fully engaged into the outlet of turbocharger (3) and into exhaust elbow (4). Ensure that the gap between the turbocharger and the exhaust elbow is evenly spaced.
6. Tighten bolts (5) to a torque of 44 N·m (32 lb ft).
7. Install exhaust tube assembly (1) onto exhaust elbow (4). Refer to the OEM for the correct installation procedure.

Inlet and Exhaust Valve Springs - Remove and Install

Removal Procedure

Table 17

Required Tools			
Tool	Part Number	Part Description	Qty
A	21825739	Valve Spring Compressor	1
	27610235	Adapter	1
	27610295	Head	1
B ⁽¹⁾	T400011	Crankshaft Turning Tool	1
B ⁽²⁾	27610291	Housing	1
	27610289	Engine Turning Tool	1

(1) The Crankshaft Turning Tool is used on the front pulley.

(2) This Tool is used in the aperture for the electric starting motor.

Start By:

- a. Remove the rocker shaft assembly. Refer to Disassembly and Assembly, "Rocker Shaft and Pushrod - Remove" for the correct procedure.

Note: Either Tooling (B) can be used. Use the Tooling that is most suitable.

NOTICE

Keep all parts clean from contaminants.

Contaminants may cause rapid wear and shortened component life.

Note: The following procedure should be adopted in order to remove the valve springs when the cylinder head is installed to the engine. Refer to Disassembly and Assembly, "Inlet and Exhaust Valves - Remove and Install" for the procedure to remove the valve springs from a cylinder head that has been removed from the engine.

Note: Ensure that the appropriate piston is at top dead center before the valve spring is removed. Failure to ensure that the piston is at top dead center may allow the valve to drop into the cylinder bore.

⚠ WARNING

Personal injury can result from being struck by parts propelled by a released spring force.

Make sure to wear all necessary protective equipment.

Follow the recommended procedure and use all recommended tooling to release the spring force.

NOTICE

Plug the apertures for the push rods in the cylinder head in order to prevent the entry of loose parts into the engine.

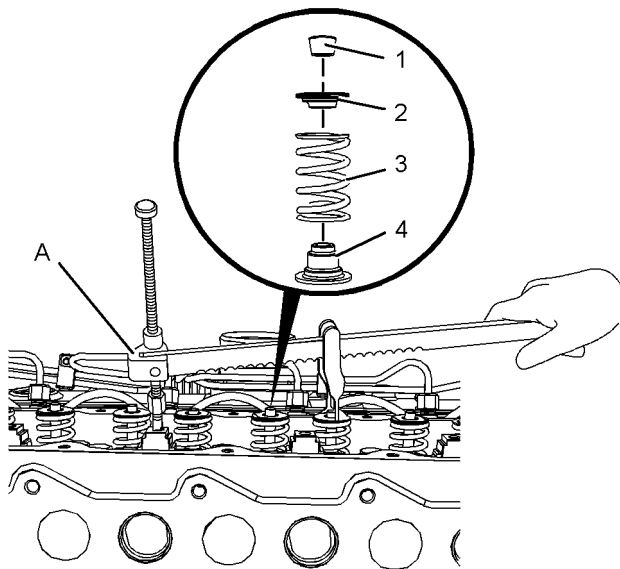

Illustration 69

g02725667

NOTICE

Ensure that the valve spring is compressed squarely or damage to the valve stem may occur.

1. Follow Step 1.a through Step 1.d in order to position the appropriate piston at top dead center.
 - a. Install Tooling (A) in position on the cylinder head in order to compress a valve spring (3) for the appropriate cylinder.
 - b. Use Tooling (A) in order to compress valve spring (3) and open the valve slightly.

Note: Do not compress the spring so that valve spring retainer (2) touches valve stem seal (4).

- c. Use Tooling (B) in order to rotate the crankshaft carefully, until the piston touches the valve.

Note: Do not use excessive force to turn the crankshaft. The use of force can result in bent valve stems.

- d. Continue to rotate the crankshaft and gradually release the pressure on Tooling (A) until the piston is at the top dead center position. The valve is now held in a position that allows the valve spring to be safely removed.

Note: Valve springs must be replaced in pairs for the inlet valve or the exhaust valve of each cylinder. If all valve springs require replacement, the procedure can be carried out on two cylinders at the same time. The procedure can be carried out on the following pairs of cylinders. 1 with 6, 2 with 5, and 3 with 4. Ensure that all of the valve springs are installed before changing from one pair of cylinders to another pair of cylinders.

NOTICE

Do not turn the crankshaft while the valve springs are removed.

2. Apply sufficient pressure to Tooling (A) in order to allow removal of valve keepers (1).

Note: Do not compress the spring so that valve spring retainer (2) touches valve stem seal (4).

3. Slowly release pressure on Tooling (A).
4. Remove valve spring retainer (2).
5. Remove valve spring (3).
6. If necessary, remove valve stem seals (4). The inlet and exhaust valve stem seals are different, the valve stem seals are denoted by the color. Identify the position of the different color valve stem seals for installation purposes.
7. Repeat Step 2 through Step 6 in order to remove the remaining valve springs from the appropriate cylinder.
8. Remove Tooling (A).

Installation Procedure

Table 18

Required Tools			
Tool	Part Number	Part Description	Qty
A	21825739	Valve Spring Compressor	1
	27610235	Adapter	1
	27610295	Head	1
B ⁽¹⁾	T400011	Crankshaft Turning Tool	1
B ⁽²⁾	27610291	Housing	1
	27610291	Engine Turning Tool	1

⁽¹⁾ The Crankshaft Turning Tool is used on the front pulley.

⁽²⁾ This Tool is used in the aperture for the electric starting motor.

Note: Either Tooling (B) can be used. Use the Tooling that is most suitable.

NOTICE

Keep all parts clean from contaminants.

Contaminants may cause rapid wear and shortened component life.

NOTICE

Do not turn the crankshaft while the valve springs are removed.

NOTICE

Plug the apertures for the push rods in the cylinder head in order to prevent the entry of loose parts into the engine.

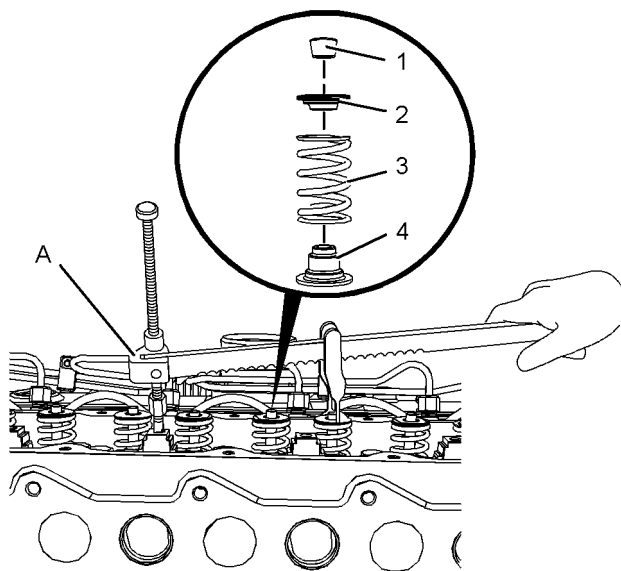

Illustration 70

g02725667

1. Inspect valve springs (3) for damage and for the correct length. Refer to Specifications, "Cylinder Head Valves " for more information.

2. If necessary, install a new valve stem seal (4) onto the valve guide. The inlet and exhaust valve stem seals are different, the valve stem seals are denoted by the color.

Note: The outer face of the valve guide must be clean and dry before installing the valve stem seal.

3. Install valve spring (3) onto the cylinder head. Position valve spring retainer (2) on valve spring (3).

WARNING

Improper assembly of parts that are spring loaded can cause bodily injury.

To prevent possible injury, follow the established assembly procedure and wear protective equipment.

NOTICE

Ensure that the valve spring is compressed squarely or damage to the valve stem may occur.

4. Install Tooling (A) in the appropriate position on the cylinder head in order to compress valve spring (3).

5. Apply sufficient pressure to Tooling (A) in order to install valve keepers (1).

Note: Do not compress the spring so that valve spring retainer (2) touches valve stem seal (4).

6. Install valve spring keepers (1).

7. Carefully release the pressure on Tooling (A).

8. Repeat Step 2 through Step 7 for the remaining valve springs.

WARNING

The valve spring keepers can be thrown from the valve when the valve spring compressor is released. Ensure that the valve spring keepers are properly installed on the valve stem. To help prevent personal injury, keep away from the front of the valve spring keepers and valve springs during the installation of the valves.

9. Remove Tooling (A).

Note: If all valve springs require replacement, the procedure can be carried out on two cylinders at the same time. The procedure can be carried out on the following cylinders. 1 and 6, 2 and 5, and 3 and 4. Remember that the crankshaft must not be turned while the valve springs are removed. Ensure that all of the valve springs are installed before changing from one pair of cylinders to the other pair of cylinders. If all valve springs do not require replacement, the springs must be replaced in pairs.

End By:

- a. Install the rocker shaft assembly. Refer to Disassembly and Assembly, "Rocker Shaft and Pushrod - Install" for the correct procedure.

i04473060

Inlet and Exhaust Valves - Remove and Install

Removal Procedure

Table 19

Required Tools			
Tool	Part Number	Part Description	Qty
A	21825739	Valve Spring Compressor	1
	27610235	Adapter	1
	27610295	Head	1

Start By:

- a. Remove the cylinder head. Refer to Disassembly and Assembly, "Cylinder Head - Remove" for the correct procedure.

NOTICE

Keep all parts clean from contaminants.

Contaminants may cause rapid wear and shortened component life.

1. Clean the bottom gasket surface of the cylinder head. Check the depth of the valves below the face of the cylinder head before the valve springs are removed. Refer to Specifications, "Cylinder Head Valves" for the correct dimensions.
2. Place a temporary identification mark on the heads of the valves in order to identify the correct position.

Note: Inlet valves have a recess in the center of the head.

3. Use a suitable lifting device to position the cylinder head with the valve springs upward. The weight of the cylinder head is approximately 96 kg (212 lb).

Note: Ensure that the cylinder head is kept on a clean, soft surface in order to prevent damage to the machined face.

WARNING

Personal injury can result from being struck by parts propelled by a released spring force.

Make sure to wear all necessary protective equipment.

Follow the recommended procedure and use all recommended tooling to release the spring force.

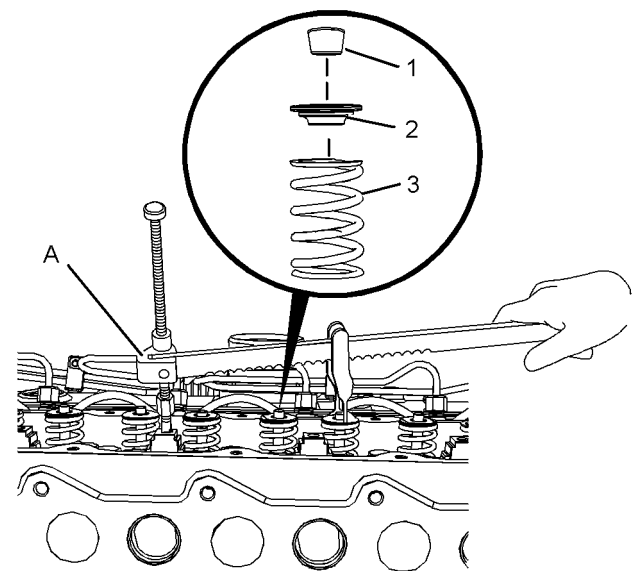

Illustration 71

g02727668

4. Install Tooling (A) into position on the cylinder head in order to compress appropriate valve spring (3).

NOTICE

Ensure that the valve spring is compressed squarely or damage to the valve stem may occur.

5. Apply sufficient pressure to Tooling (A) in order to remove valve keepers (1).

Note: Do not compress the spring so that valve spring retainer (2) touches valve stem seal (4).

6. Slowly release the pressure on Tooling (A).

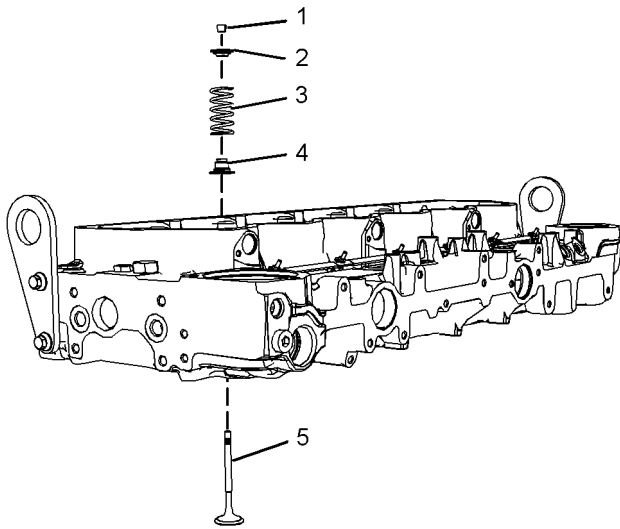

Illustration 72

g02727669

7. Place a temporary identification mark on valve spring (3) in order to identify the correct position.
8. Remove valve spring retainer (2). Remove valve spring (3).
9. Repeat Step 4 through Step 8 for the remaining valves.
10. Remove Tooling (A).
11. Remove valve stem seals (4). The inlet and exhaust valve stem seals are different, the valve stem seals are denoted by the color. Identify the position of the different color valve stem seals for installation purposes.
12. Use a suitable lifting device to turn over the cylinder head.
13. Place a temporary identification mark on valves (5). Remove valves (5) from the cylinder head.

Installation Procedure

Table 20

Required Tools			
Tool	Part Number	Part Description	Qty
A	21825739	Valve Spring Compressor	1
	27610235	Adapter	1
	27610295	Head	1

NOTICE

Keep all parts clean from contaminants.

Contaminants may cause rapid wear and shortened component life.

Note: The valves have a hard surface finish. Grinding compound must not be used on the valves. Grinding compound will damage the hard surface finish of the valves.

1. Clean all components of the cylinder head assembly. Ensure that all ports, all coolant passages, and, all lubrication passages in the cylinder head are free from debris. Follow Step 1.a through Step 1.e in order to inspect the components of the cylinder head assembly. Replace any components that are worn or damaged.
 - a. Inspect the cylinder head for wear and for damage. Refer to System Operation, Testing and Adjusting, "Cylinder Head Inspect" for the correct procedure.
 - b. Inspect the valve seats for wear and for damage. Refer to Specifications, "Cylinder Head Valves" for more information.
 - c. Inspect the valve guides for wear and for damage. Refer to Specifications, "Cylinder Head Valves" and System Operation, Testing and Adjusting, "Valve Guide - Inspect" for more information.
 - d. Inspect the valves for wear and for damage. Refer to Specifications, "Cylinder Head Valves" for more information.
 - e. Inspect the valve springs for damage and for the correct length. Refer to Specifications, "Cylinder Head Valves" for more information.

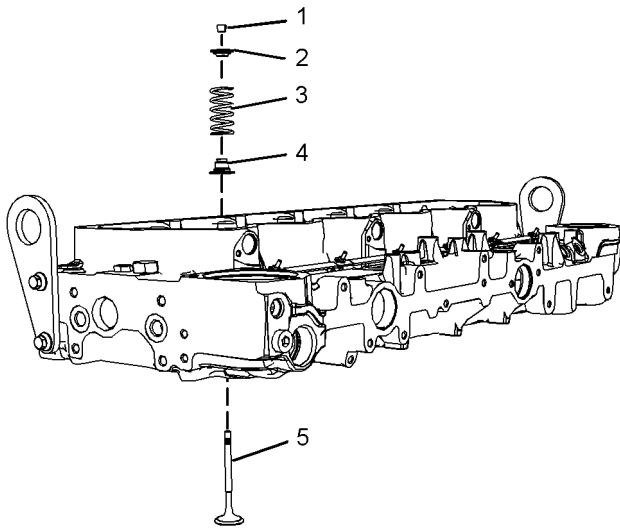

Illustration 73

g02727669

2. Lubricate the stems of valves (5) with clean engine oil. Install valves (5) in the appropriate positions in the cylinder head. Check the depth of the valves below the face of the cylinder head. Refer to System Operation, Testing and Adjusting, "Valve Depth - Inspect" for more information.
3. Use a suitable lifting device to turn over the cylinder head. The weight of the cylinder head is approximately 96 kg (212 lb).

Note: Ensure that all of the valves remain in place.

4. Install new valve stem seals (4) onto each of the valve guides. The inlet and exhaust valve stem seals are different, the valve stem seals are denoted by the color.

Note: The outer face of the valve guides must be clean and dry before installing valve stem seals (4).

5. Install valve spring (3) onto the cylinder head. Position valve spring retainer (2) on valve spring (3).

WARNING

Personal injury can result from being struck by parts propelled by a released spring force.

Make sure to wear all necessary protective equipment.

Follow the recommended procedure and use all recommended tooling to release the spring force.

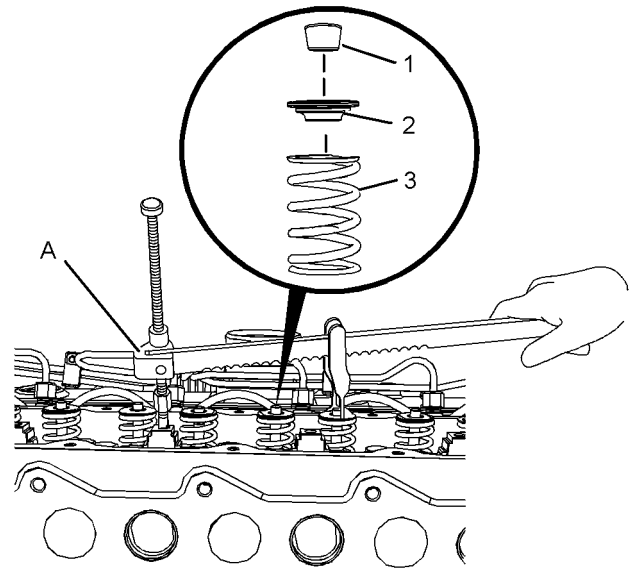

Illustration 74

g02727668

6. Install Tooling (A) in the appropriate position on the cylinder head in order to compress valve spring (3).

NOTICE

Ensure that the valve spring is compressed squarely or damage to the valve stem may occur.

7. Apply sufficient pressure to Tooling (A) in order to install valve keepers (1).

Note: Do not compress the spring so that valve spring retainer (2) touches valve stem seal (4).

WARNING

The valve spring keepers can be thrown from the valve when the valve spring compressor is released. Ensure that the valve spring keepers are properly installed on the valve stem. To help prevent personal injury, keep away from the front of the valve spring keepers and valve springs during the installation of the valves.

8. Carefully release the pressure on Tooling (A).
9. Repeat Step 5 through Step 8 for the remaining valves.
10. Remove Tooling (A) from the cylinder head.

End By:

- a. Install the cylinder head. Refer to Disassembly and Assembly, "Cylinder Head - Install" for the correct procedure.

i04683730

Inlet and Exhaust Valve Guides - Remove and Install

Removal Procedure

Table 21

Required Tools			
Tool	Part Number	Part Description	Qty
A	T400098	Valve Guide Driver	1

Start By:

- a. Remove the inlet valves and the exhaust valves. Refer to Disassembly and Assembly, "Inlet and Exhaust Valves - Remove and Install".

NOTICE

Removal and installation of the valve guide and valve seat must be carried out by personnel with the correct training. Also special machinery is required. For more information, refer to your authorized Perkins Distributor/Dealer.

NOTICE

Keep all parts clean from contaminants.

Contaminants may cause rapid wear and shortened component life.

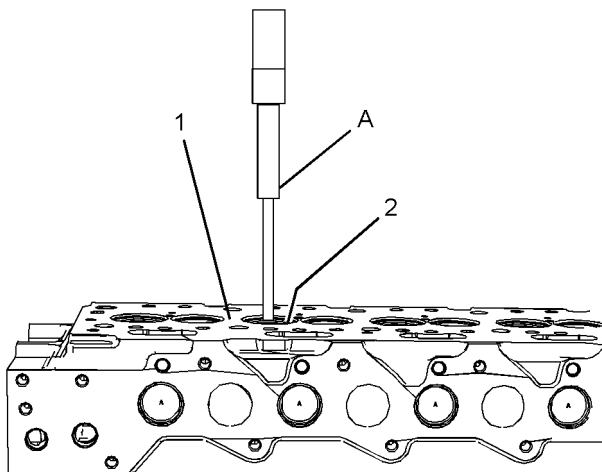

Illustration 75

g02797427

1. Use a suitable press and Tooling (A) in order to remove valve guides (2) (not shown) from cylinder head (1).

2. Repeat the Step 1 for the remaining valve guides.

Installation Procedure

Table 22

Required Tools			
Tool	Part Number	Part Description	Qty
A	T400098	Valve Guide Driver	1
	T400099	Stop Collar	1
B	27610030	Valve Seat Cutter	1

NOTICE

Removal and installation of the valve guide and valve seat must be carried out by personnel with the correct training. Also special machinery is required. For more information, refer to your authorized Perkins Distributor/Dealer.

NOTICE

Keep all parts clean from contaminants.

Contaminants may cause rapid wear and shortened component life.

1. Clean the parent bores in the cylinder head for the valve guides.

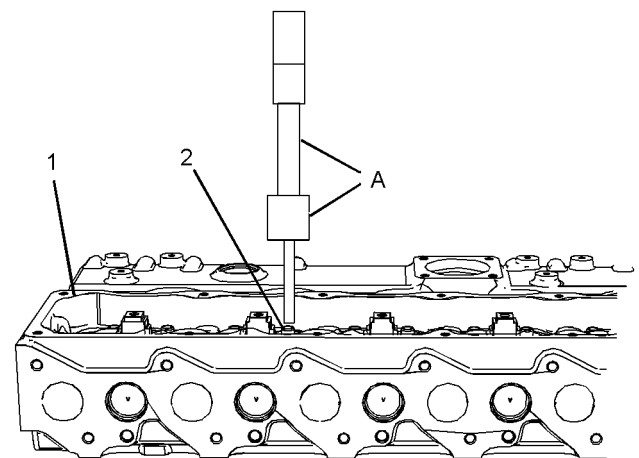

Illustration 76

g02797428

2. Lubricate a new valve guide (2) with clean engine oil. Place valve guide (2) into position on cylinder head (1). Carefully tap the valve guide in order to start the installation.
3. Use a suitable press and Tooling (A) in order to install the valve guide into the cylinder head.

i04472970

4. Repeat Step 2 through Step 3 for the remaining valve guides.

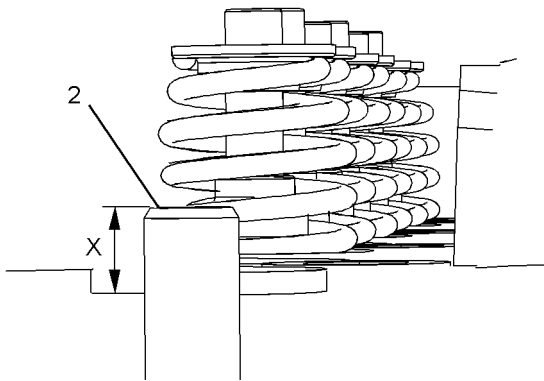

Illustration 77

g02797429

5. Check Protrusion (X) of valve guides (2). The valve guides should protrude 12.7 mm (0.500 inch) above the valve spring recess. Refer to Specifications, "Cylinder Head Valves" for more information.
6. After installation of valve guides (2), the valve guides must be reamed and the valve seat inserts must be cut to the finished diameter. Follow Steps 6.a through 6.d in order to ream the valve guides and cut the valve seat inserts.
- Lubricate the bores of valve guides (2) with clean engine oil.
 - Use Tooling (B) in order to ream the valve guides. Ensure that even pressure is applied to Tooling (B).
 - Use Tooling (B) in order to cut the valve seats. Ensure that even pressure is applied to Tooling (B).
 - Ensure that the cylinder head is clean and free from machining debris.
7. Check the finished diameter of valve guides (2). Refer to Specifications, "Cylinder Head - Valves" for more information.
8. Check the depths of the valves below the face of the cylinder head. Refer to System Operation, Testing and Adjusting, "Valve Depth - Inspect" for more information.

End By:

- Install the inlet valves and the exhaust valves. Refer to Disassembly and Assembly, "Inlet and Exhaust Valves - Remove and Install".

Engine Oil Filter Base - Remove and Install

Removal Procedure

Table 23

Required Tools			
Tool	Part Number	Part Description	Qty
A	-	Chain Wrench	1

NOTICE

Keep all parts clean from contaminants.

Contaminants may cause rapid wear and shortened component life.

NOTICE

Care must be taken to ensure that fluids are contained during performance of inspection, maintenance, testing, adjusting, and repair of the product. Be prepared to collect the fluid with suitable containers before opening any compartment or disassembling any component containing fluids.

Dispose of all fluids according to local regulations and mandates.

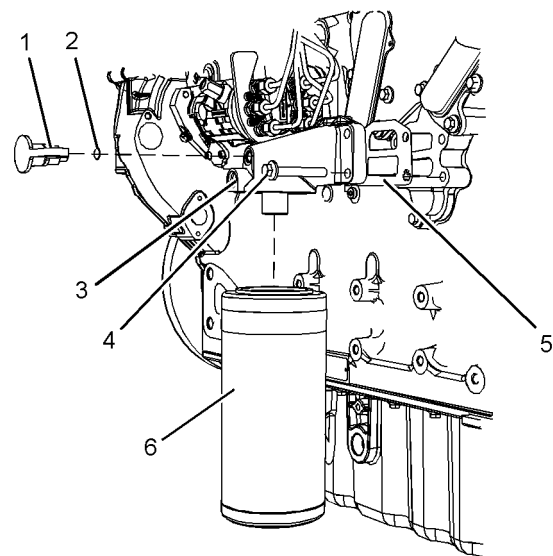

Illustration 78

g02701759

- Place a suitable container below engine oil filter (6) in order to catch any oil that might be spilled.

2. Use Tooling (A) to remove engine oil filter (6). Refer to Operation and Maintenance Manual, "Engine Oil and Filter - Change" for the correct procedure.
3. Remove bolts (4).
4. Remove engine oil filter base (3).
5. Remove gasket (5).
6. If necessary, remove valve (1) from engine oil filter base (3). Remove O-ring seal (2) from valve (1).

Installation Procedure

NOTICE

Keep all parts clean from contaminants.

Contaminants may cause rapid wear and shortened component life.

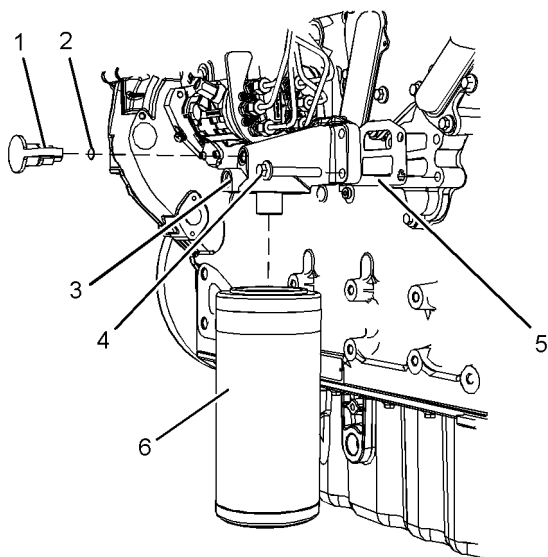

Illustration 79

g02701759

1. Clean engine oil filter base (3). Clean the gasket surfaces of the engine oil cooler.
2. If necessary, install new O-ring seal (2) to valve (1). Install valve (1) to engine oil filter base (3). Tighten the valve to a torque of 12 N·m (106 lb in).
3. Install bolts (4) to engine oil filter base (3).
4. Install a gasket (5) onto bolts (4). Install the assembly of the engine oil filter base to the engine oil cooler.
5. Tighten bolts (4) to a torque of 22 N·m (195 lb in).

6. Install a new engine oil filter (6) and check the level of the engine lubricating oil. Refer to Operation and Maintenance Manual, "Engine Oil Level - Check" for the correct procedure.

i04472969

Engine Oil Cooler - Remove

Removal Procedure

NOTICE

Ensure that all adjustments and repairs that are carried out to the fuel system are performed by authorized personnel that have the correct training.

Before beginning ANY work on the fuel system, refer to Operation and Maintenance Manual, "General Hazard Information and High Pressure Fuel Lines" for safety information.

Refer to System Operation, Testing and Adjusting, "Cleanliness of Fuel System Components" for detailed information on the standards of cleanliness that must be observed during ALL work on the fuel system.

NOTICE

Keep all parts clean from contaminants.

Contaminants may cause rapid wear and shortened component life.

NOTICE

Care must be taken to ensure that fluids are contained during performance of inspection, maintenance, testing, adjusting and repair of the product. Be prepared to collect the fluid with suitable containers before opening any compartment or disassembling any component containing fluids.

Dispose of all fluids according to local regulations and mandates.

1. Drain the coolant from the cooling system into a suitable container. Refer to Operation and Maintenance Manual, "Cooling System Coolant - Drain" for the correct procedure.
2. Place a suitable container below the engine oil cooler in order to catch any fluids that might be spilled.

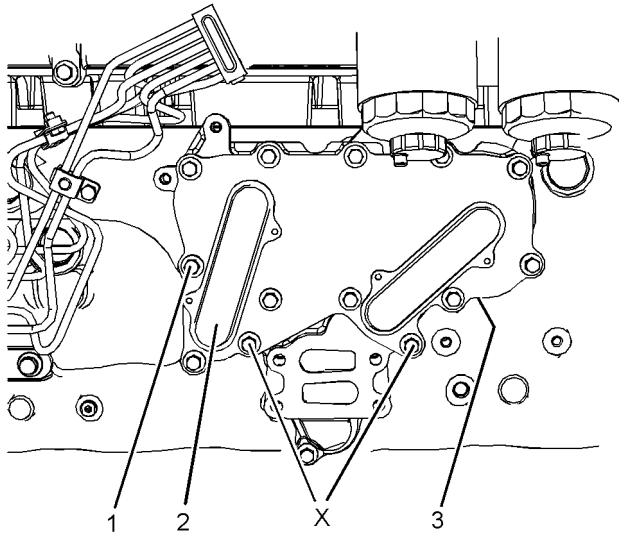

Illustration 80

g02704276

3. Remove the oil filter base. Refer to Disassembly and Assembly, "Oil Filter Base - Remove and Install".

4. Remove bolts (1) from the assembly of engine oil cooler (2). Note the position of different length bolts. Do not remove bolts in Position (X).

Note: Support the engine oil cooler as the bolts are removed.

5. Remove the assembly of engine oil cooler (2) from the cylinder block.

6. Remove gasket (3) (not shown).

Disassembly Procedure

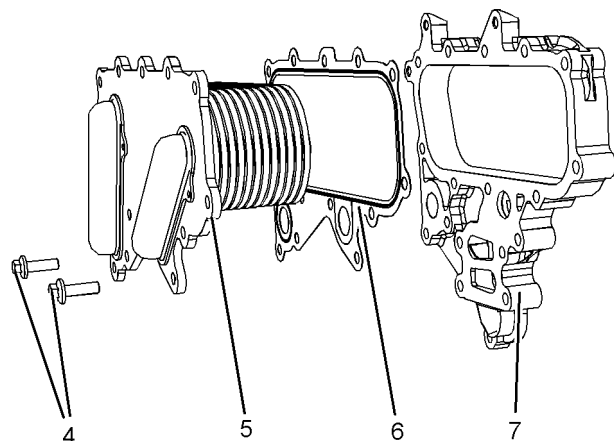

Illustration 81

g02704316

1. Remove bolts (4).
2. Remove cooler matrix (5) from spacer plate (7).
3. Remove gasket (6).

i04472968

Engine Oil Cooler - Install

Assembly Procedure

NOTICE

Keep all parts clean from contaminants.

Contaminants may cause rapid wear and shortened component life.

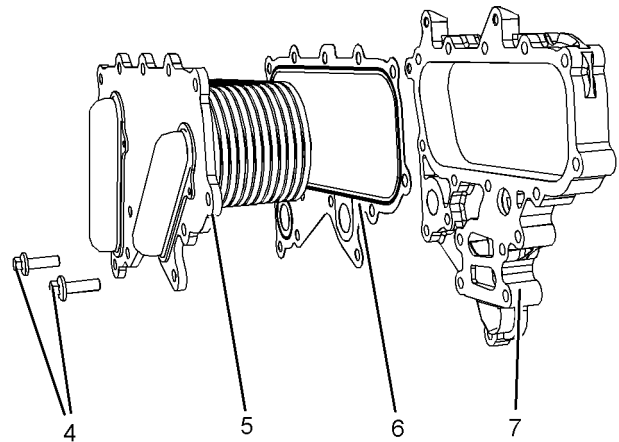

Illustration 82

g02704316

1. Ensure that cooler matrix (5) is clean, free from restriction, and free from damage. Ensure that spacer plate (7) is clean and free from damage. Replace any damaged components.
2. Position a new joint (6) onto spacer plate (7). Install cooler matrix (5) to the spacer plate.
3. Install bolts (4) finger tight.

Installation Procedure

Table 24

Required Tools			
Tool	Part Number	Part Description	Qty
A	-	Guide Studs (M8 by 70 mm)	2

1. Clean the gasket surface of the cylinder block.

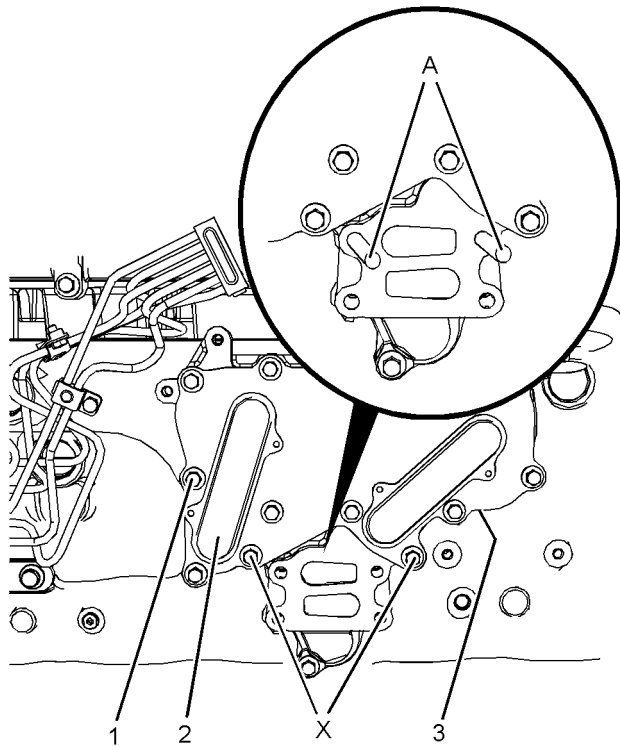

Illustration 83

g02721610

i04472991

4. Install the assembly of oil cooler (2) onto Tooling (A) . Ensure that the assembly of the oil cooler is correctly located into the recess of the cylinder block.
5. Tighten bolts (1) finger tight.
6. Remove Tooling (A).
7. Install remaining bolts (1) to assembly of engine oil cooler (2).
8. Tighten bolts (1) to a torque of 22 N·m (195 lb in) in the sequence that is shown in Illustration 84.
9. Install the oil filter base. Refer to Disassembly and Assembly, "Oil Filter Base - Remove and Install" for the correct procedure.
10. Fill the cooling system to the correct level. Refer to Operation and Maintenance Manual, "Cooling System Coolant - Change" for the correct procedure.
11. Check the level of the engine lubricating oil. Refer to Operation and Maintenance Manual, "Engine Oil Level - Check" for the correct procedure.

Engine Oil Pump - Remove

Removal Procedure

Start By:

- a. Remove the engine oil pan. Refer to Disassembly and Assembly, "Engine Oil Pan - Remove".

NOTICE

Keep all parts clean from contaminants.

Contaminants may cause rapid wear and shortened component life.

NOTICE

Care must be taken to ensure that fluids are contained during performance of inspection, maintenance, testing, adjusting and repair of the product. Be prepared to collect the fluid with suitable containers before opening any compartment or disassembling any component containing fluids.

Dispose of all fluids according to local regulations and mandates.

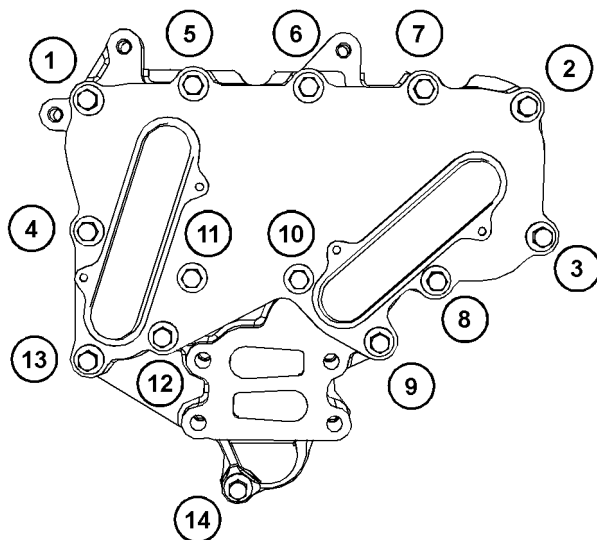

Illustration 84

g02704416

Tightening sequence for an engine oil cooler

2. Position a new gasket (3) (not shown) onto the assembly of engine oil cooler (2). Install bolts (1) to the serrated holes in the gasket.

Note: Ensure that the bolts of different length are installed in the correct position.

3. Install Tooling (A) to the cylinder block.

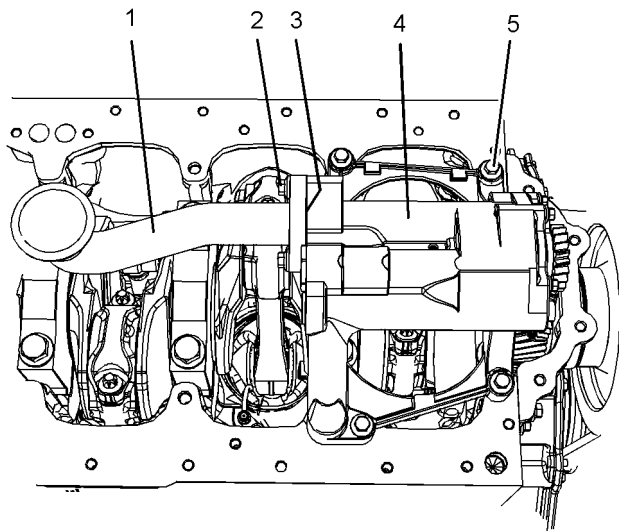

Illustration 85

g02699477

1. Remove bolts (2) and remove suction pipe (1).
2. Remove gasket (3) (not shown).
3. Remove bolts (5). Remove the assembly of engine oil pump (4) from the cylinder block.

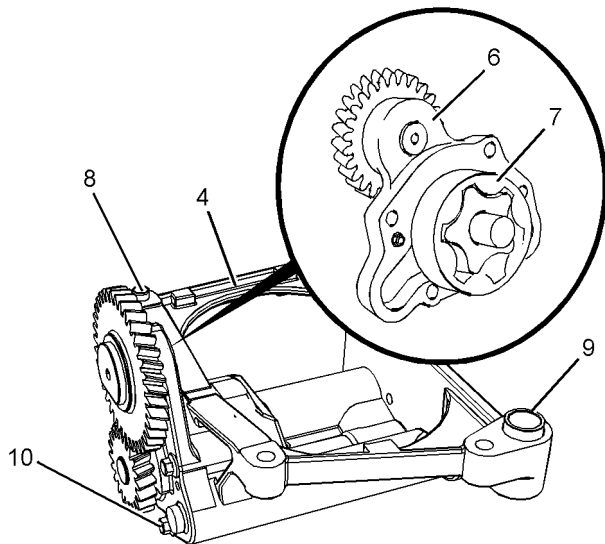

Illustration 86

g02699478

4. If necessary, remove bolts (10) from front cover assembly (6) of the engine oil pump. Remove front cover assembly (6) from engine oil pump (4).
5. Make temporary marks on outer rotor (7). Remove outer rotor (7) from the housing of engine oil pump (4).

6. Do not remove dowel (8) or dowel (9) from the housing of the engine oil pump unless the dowels are damaged.

i04472990

Engine Oil Pump - Install

Installation Procedure

Table 25

Required Tools			
Tool	Part Number	Part Description	Qty
A	21825496	Indicator Bracket	1
	21825617	Dial Indicator	1
	-	Indicator Contact Point	1
	-	Universal Attachment	1

NOTICE

Keep all parts clean from contaminants.

Contaminants may cause rapid wear and shortened component life.

NOTICE

If any part of the engine oil pump is worn or damaged, the complete assembly of the engine oil pump must be replaced.

1. Ensure that all components of the engine oil pump are clean and free from wear or damage. Refer to System Operation, Testing and Adjusting, "Engine Oil Pump - Inspect" for more information. Replace the complete assembly of the engine oil pump if any of the components are worn or damaged.

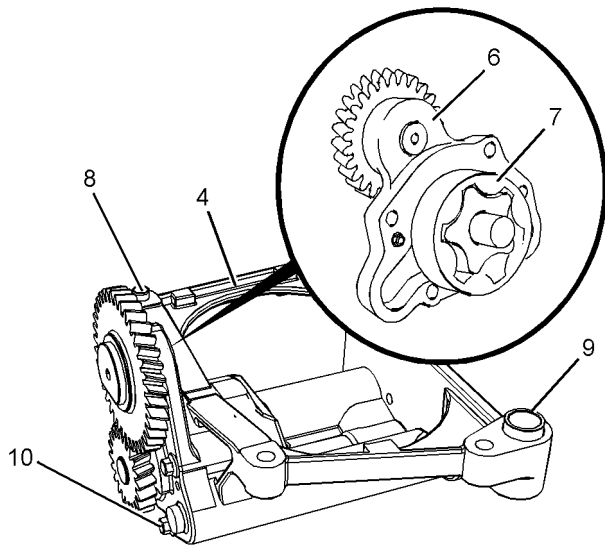

Illustration 87

g02699478

2. If necessary, lubricate the internal components for the assembly of the engine oil pump with clean engine oil. Install outer rotor (7) into housing of engine oil pump (4).

Note: Ensure that the outer rotor is correctly installed into the housing of the engine oil pump.

3. Install front cover (6) to the housing of engine oil pump (4).

Note: Ensure that the front cover dowels are correctly located onto the engine oil pump.

4. Install bolts (10). Tighten the bolts to a torque of 9 N·m (80 lb in).
5. Ensure that two dowel (8) and dowel (9) are correctly located in the housing of engine oil pump (4).

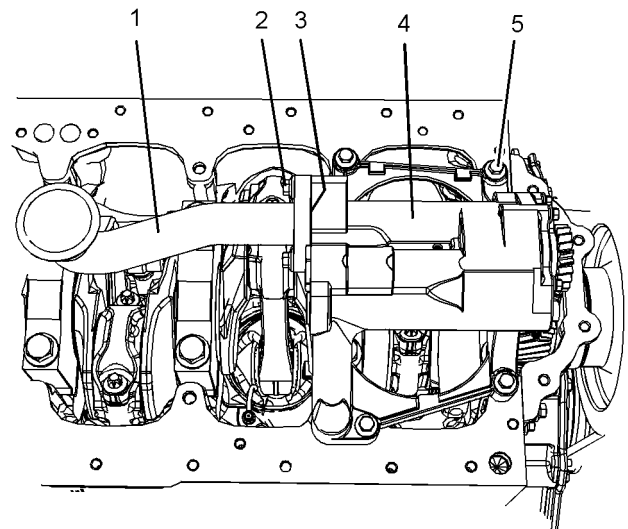

Illustration 88

g02699477

6. Position the assembly of the engine oil pump onto the cylinder block.

Note: Ensure that the dowels in the housing of the engine oil pump are aligned with the holes in the cylinder block.

7. Install bolts (5). Tighten the bolts to a torque of 22 N·m (195 lb in).
8. Use Tooling (A) in order to check the backlash between the idler gear and the crankshaft gear. Refer to Specifications, "Gear Group (Front)" for further information.
9. Position a new (3) (not shown) onto suction pipe (2)
10. Position suction pipe (2) onto engine oil pump (4).
11. Install bolts (2). Tighten the bolts to a torque to 22 N·m (195 lb in).

End By:

- a. Install the engine oil pan. Refer to Disassembly and Assembly, "Engine Oil Pan - Install".

i04473102

Water Pump - Remove

Removal Procedure

Start By:

- a. Remove the fan and the fan pulley. Refer to Disassembly and Assembly, "Fan - Remove and Install".

NOTICE

Keep all parts clean from contaminants.

Contaminants may cause rapid wear and shortened component life.

NOTICE

Care must be taken to ensure that fluids are contained during performance of inspection, maintenance, testing, adjusting and repair of the product. Be prepared to collect the fluid with suitable containers before opening any compartment or disassembling any component containing fluids.

Dispose of all fluids according to local regulations and mandates.

1. Drain the coolant from the cooling system into a suitable container for storage or disposal. Refer to Operation and Maintenance Manual, "Cooling System Coolant - Change" for the correct procedure.
2. Loosen the hose clamps and remove the hose from the water pump inlet.

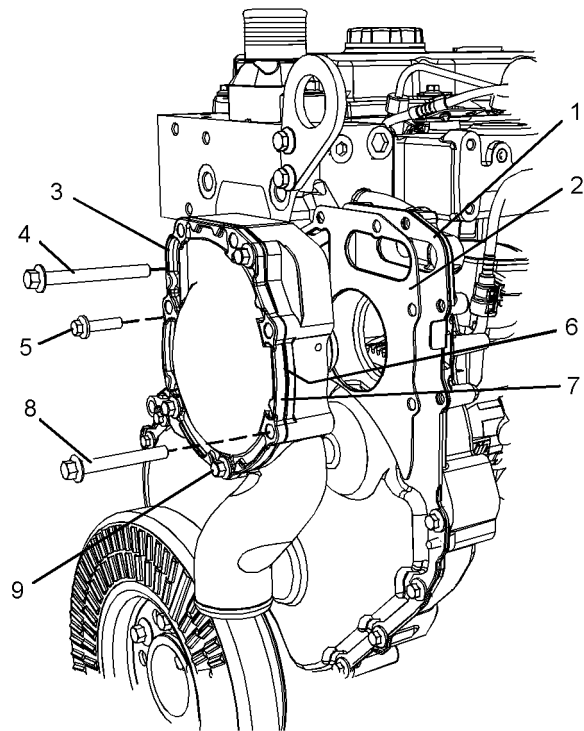

Illustration 89

g02717775

3. Remove bolts (4), bolts (5), and bolts (8).

Note: The bolts are three different lengths. Note the positions of the three length different bolts.

4. Remove water pump (3) from front cover (1).

Note: If necessary, tap the water pump with a soft hammer in order to loosen the water pump.

5. Remove gasket (2).

6. If necessary, remove the cover from the water pump. Follow Step 6.a through Step 6.c in order to remove the cover.

- a. Remove bolts (9).
- b. Remove cover (7).
- c. Remove gasket (6) (not shown).

i04473099

Water Pump - Install

Installation Procedure

Table 26

Required Tools			
Tool	Part Number	Part Description	Qty
A	-	Guide Studs (M8 by 70 mm)	2

NOTICE

Keep all parts clean from contaminants.

Contaminants may cause rapid wear and shortened component life.

NOTICE

Care must be taken to ensure that fluids are contained during performance of inspection, maintenance, testing, adjusting and repair of the product. Be prepared to collect the fluid with suitable containers before opening any compartment or disassembling any component containing fluids.

Dispose of all fluids according to local regulations and mandates.

1. Ensure that the water pump is clean and free from wear or damage. If necessary, replace the water pump.

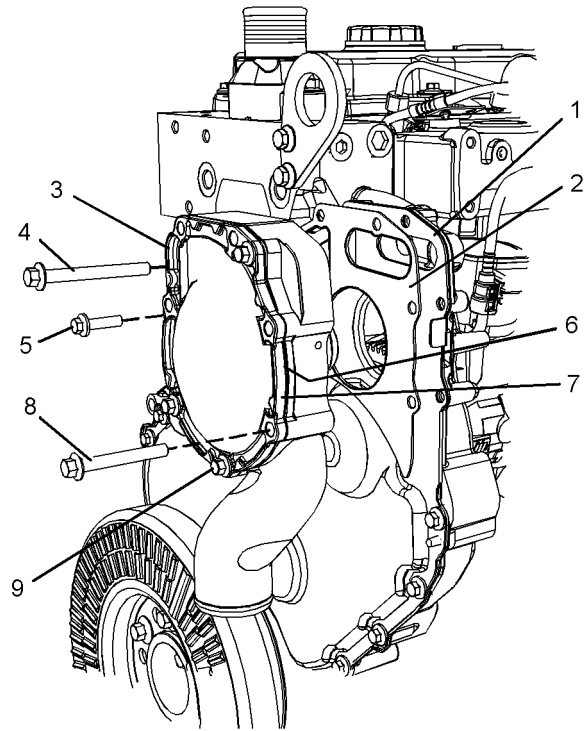

Illustration 90

g02717775

2. If necessary, install the cover to the water pump . Follow Steps 2.a through 2.d in order to install the cover.
 - a. Clean the gasket surface of cover (7).
 - b. Position a new gasket (6) (not shown) on water pump (3).
 - c. Install cover (7) to water pump (3).
 - d. Install bolts (9) to cover (7). Tighten bolts finger tight.

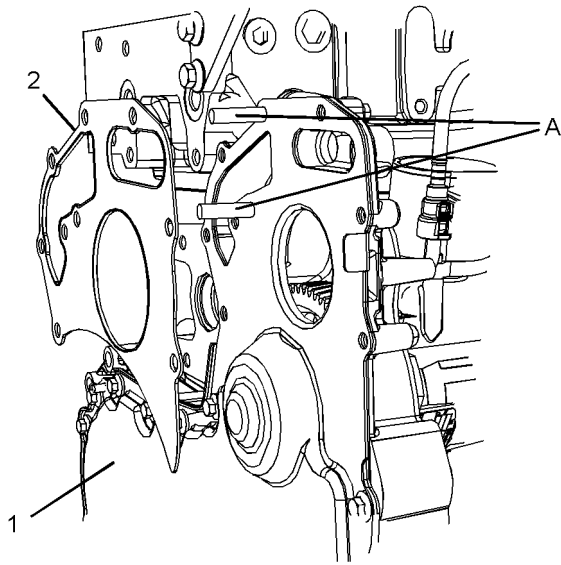

Illustration 91 g02721481

3. Clean the gasket surface of front cover (1).
4. Install Tooling (A) in Position (X).
5. Use Tooling (A) in order to align new gasket (2) to front cover (1). Install the gasket to the front cover.
6. Align water pump (3) to Tooling (A). Install the water pump to front cover (1).

Note: Ensure that the gear of the water pump and the gear of the fuel injection pump mesh.

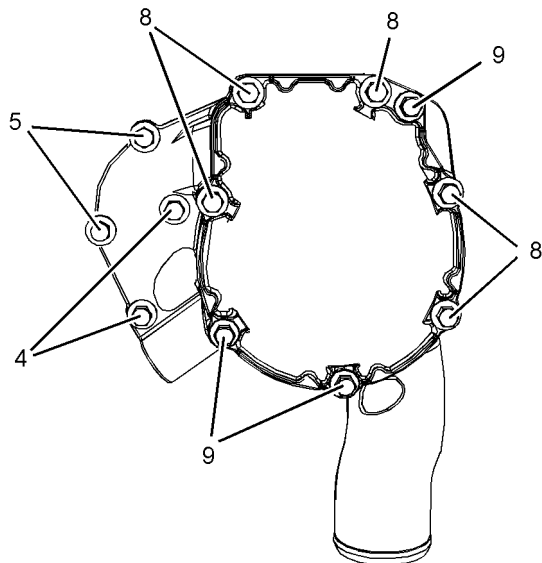

Illustration 92 g02721493

Bolts (9) for cover plate.

- (5) M8 by 30 mm
- (4) M8 by 75 mm
- (8) M8 by 65 mm

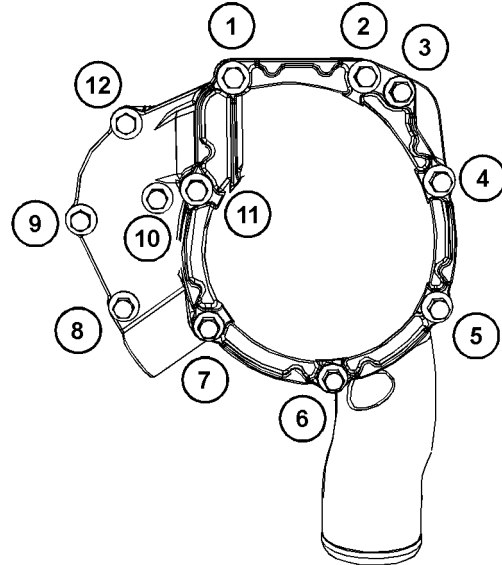

Illustration 93 g02721495

7. Install bolts (4), bolts (5), and bolts (8). Refer to Illustration 92. Tighten the bolts finger tight.
- Note:** Ensure that all bolts of different lengths are installed in the correct positions.
8. Remove Tooling (A) and install remaining bolts (4).
 9. Tighten bolts (4), bolts (5), bolts (8), and bolts (9) in the sequence that is shown in Illustration 93 to a torque of 22 N·m (195 lb in).
 10. Install the hose to the water pump inlet. Tighten the hose clamps securely.
 11. Fill the cooling system with coolant. Refer to Operation and Maintenance Manual, "Cooling System Coolant - Change" for the correct procedure.

End By:

- a. Install the fan and the fan pulley. Refer to Disassembly and Assembly, "Fan - Remove and Install".

i04473106

Water Temperature Regulator - Remove and Install

Removal Procedure

NOTICE

Keep all parts clean from contaminants.

Contaminants may cause rapid wear and shortened component life.

NOTICE

Care must be taken to ensure that fluids are contained during performance of inspection, maintenance, testing, adjusting and repair of the product. Be prepared to collect the fluid with suitable containers before opening any compartment or disassembling any component containing fluids.

Dispose of all fluids according to local regulations and mandates.

1. Drain the coolant from the cooling system to a level below the water temperature regulator, into a suitable container for storage or for disposal. Refer to Operation and Maintenance Manual, "Cooling System Coolant - Change" for the correct draining procedure.
2. Loosen the hose clamps from the upper radiator hose and disconnect the upper radiator hose from water temperature regulator housing (2).

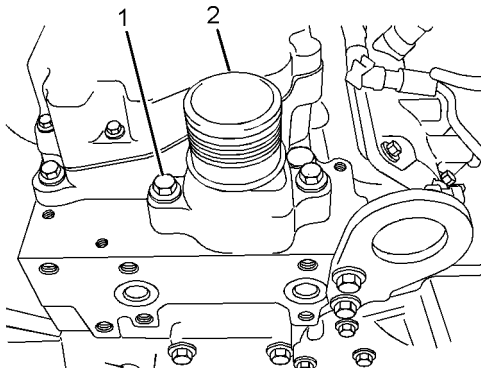

Illustration 94
Typical example

g01336665

3. Remove bolts (1) from water temperature regulator housing (2).
4. Remove water temperature regulator housing (2) from the cylinder head.

Note: Note the orientation of the water temperature regulator housing.

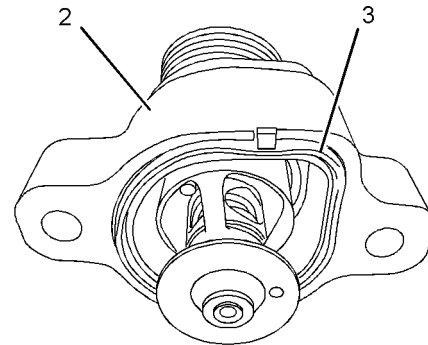

Illustration 95
Typical example

g01336667

5. Remove seal (3) from water temperature regulator housing (2).

Installation Procedure

NOTICE

Keep all parts clean from contaminants.

Contaminants may cause rapid wear and shortened component life.

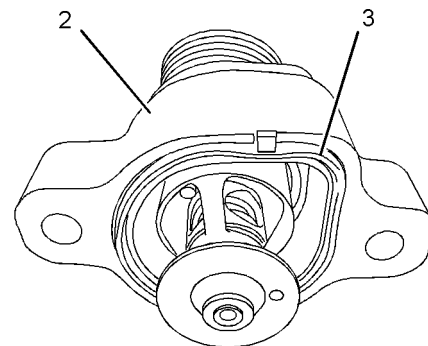

Illustration 96
Typical example

g01336667

1. Ensure that all components of water temperature regulator housing (2) are clean and free of wear or damage.
2. Check the water temperature regulator for correct operation. Refer to System Operation, Testing and Adjusting, "Water Temperature Regulator - Test" for the procedure to test the water temperature regulator. If any components of the water temperature regulator housing are worn or damaged, the complete assembly must be replaced.

3. Thoroughly clean the gasket surface of the cylinder.
4. If the original water temperature regulator housing is installed, position a new O-ring seal (3) into the groove in water temperature regulator housing (2).

A new water temperature regulator housing is supplied with a new O-ring seal.

5. Install water temperature regulator housing (2) to the cylinder head.

Note: Ensure the correct orientation of the water temperature regulator housing.

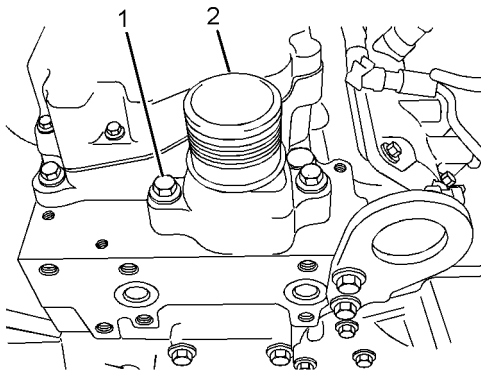

Illustration 97
Typical example g01336665

6. Install bolts (1). Tighten bolts (1) to a torque of 44 N·m (32 lb ft).
7. Connect the upper radiator hose and securely tighten the hose clamps.
8. Fill the cooling system to the correct level. Refer to Operation and Maintenance Manual, "Cooling System Coolant - Check" and Operation and Maintenance Manual, "Cooling System Coolant - Change" for the correct filling procedure.

i04472997

Flywheel - Remove

Removal Procedure

Table 27

Required Tools			
Tool	Part Number	Part Description	Qty
A	-	Guide Stud 1/2 inch - UNF by 4 inch	2

Start By:

- a. Remove the electric starting motor. Refer to Disassembly and Assembly, "Electric Starting Motor - Remove and Install" for the correct procedure.

NOTICE

Keep all parts clean from contaminants.

Contaminants may cause rapid wear and shortened component life.

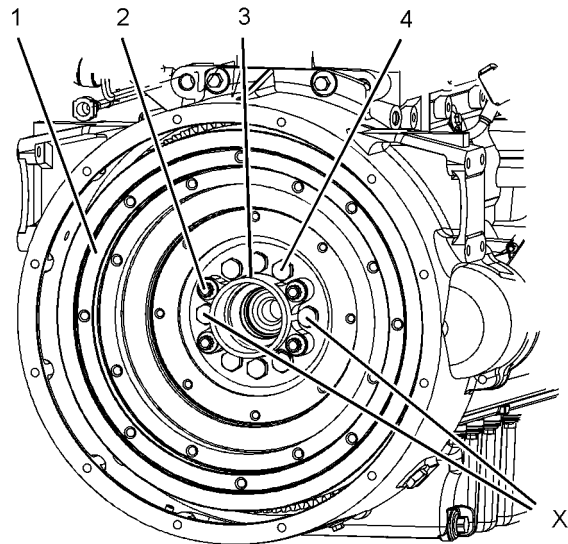

Illustration 98
Typical example g01336668

1. Remove bolts from Position (X) from flywheel (1).
2. Install Tooling (A) in Position (X) to flywheel (1).
3. Install a suitable lifting device onto flywheel (1). Support the weight of the flywheel. The flywheel can weigh 71 kg (156 lb).
4. If necessary, remove bolts (2) that secure the housing for pilot bearing (3) to flywheel (1). Remove the housing for pilot bearing (3).
5. Remove remaining bolts (4).
6. Use the lifting device to remove the flywheel from the engine.

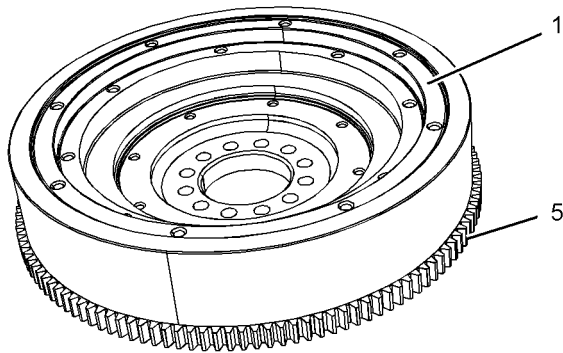

Illustration 99 g01336669
Typical example

7. Inspect flywheel (1) and ring gear (5) for wear and damage. Replace any worn components or damaged components.
8. To remove flywheel ring gear (5), follow Step 8.a through Step 8.b.
 - a. Place the flywheel assembly on a suitable support.
 - b. Use a hammer and a punch in order to remove ring gear (5) from flywheel (1).

Note: Identify the orientation of the teeth on the flywheel ring gear.

i04472996

Flywheel - Install

Installation Procedure

Table 28

Required Tools			
Tool	Part Number	Part Description	Qty
A	-	Guide Stud 1/2 inch - UNF by 4 inch	2

NOTICE

Keep all parts clean from contaminants.

Contaminants may cause rapid wear and shortened component life.

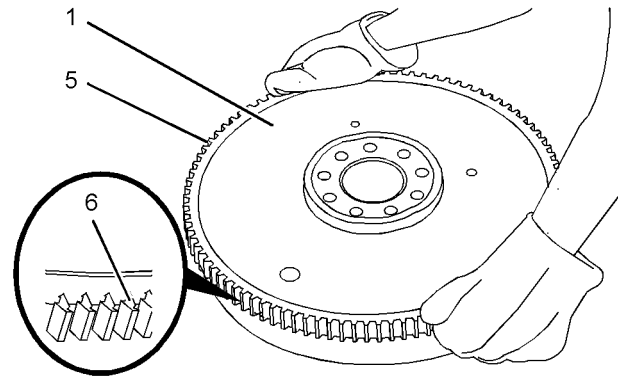

Illustration 100 g01336671
Typical example

WARNING

Always wear protective gloves when handling parts that have been heated.

1. If the flywheel ring gear was removed, follow Step 1.a through Step 1.c in order to install ring gear (5) to flywheel (1).
 - a. Identify the orientation of teeth (6) on new ring gear (5).

Note: The chamfered side of ring gear teeth (6) must face toward the starting motor when the flywheel is installed. The chamfered side of ring gear teeth ensures the correct engagement of the starting motor.

- b. Heat flywheel ring gear (5) in an oven to a maximum temperature of 250 °C (482 °F) prior to installation.

Note: Do not use a torch to heat the ring gear.

- c. Ensure that the orientation of ring gear (5) is correct and quickly install the ring gear onto flywheel (1).
2. Inspect the crankshaft rear seal for leaks. If there are any oil leaks, replace the crankshaft rear seal. Refer to Disassembly and Assembly, "Crankshaft Rear Seal - Install" for the correct procedure.

i04472964

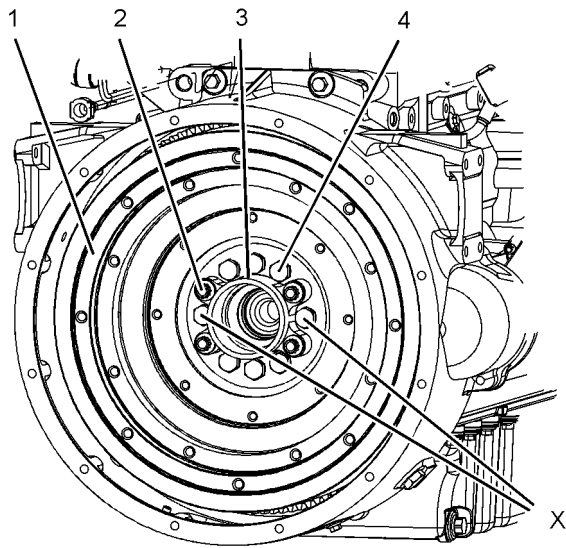

Illustration 101

g01336668

Typical example

3. Install a suitable lifting device onto flywheel (1). The flywheel can weigh 71 kg (156 lb).
4. Install Tooling (A) in Position (X) on the crankshaft.
5. Use the lifting device to position flywheel (1) onto Tooling (A).
6. If necessary, install pilot bearing (3) and bolts (2) to flywheel (1).
7. Install bolts (4) to flywheel (1).
8. Remove Tooling (A) and install remaining bolts (4) to flywheel (1).
9. Use a suitable tool to prevent the flywheel from rotating. Tighten bolts (2) and (4) to a torque of 140 N·m (103 lb ft).
10. Remove the lifting device from flywheel (1).
11. Check the run out of the flywheel. Refer to Specifications, "Flywheel" for further information.

End By:

- a. Install the electric starting motor. Refer to Disassembly and Assembly, "Electric Starting Motor - Remove and Install" for the correct procedure.

Crankshaft Rear Seal - Remove**Removal Procedure**

Table 29

Required Tools			
Tool	Part Number	Part Description	Qty
A	-	E10 Torx Socket	1

Start By:

- a. Remove the flywheel. Refer to Disassembly and Assembly, "Flywheel - Remove".

NOTICE

Keep all parts clean from contaminants.

Contaminants may cause rapid wear and shortened component life.

NOTICE

Care must be taken to ensure that fluids are contained during performance of inspection, maintenance, testing, adjusting and repair of the product. Be prepared to collect the fluid with suitable containers before opening any compartment or disassembling any component containing fluids.

Dispose of all fluids according to local regulations and mandates.

Note: The crankshaft rear seal and the housing are manufactured as a one-piece assembly. The assembly is not serviceable. If the crankshaft rear seal is removed, the assembly must be replaced.

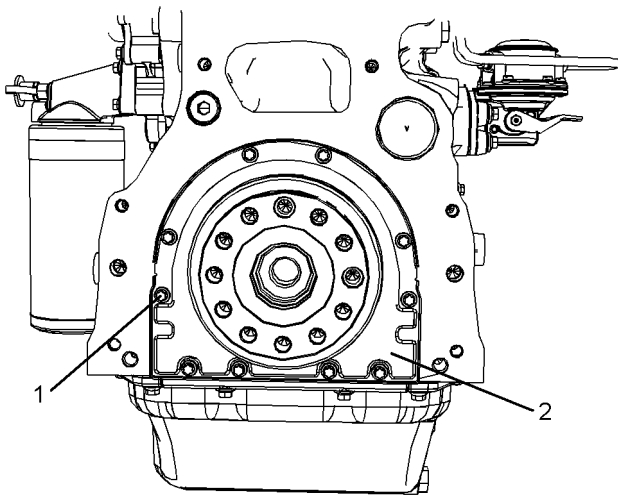

Illustration 102

g02711971

1. Use Tooling (A) in order to remove torx screws (1) from crankshaft rear seal (2).
2. Remove crankshaft rear seal (2) from the cylinder block. Discard the crankshaft rear seal.

i04472963

Crankshaft Rear Seal - Install

Installation Procedure

Table 30

Required Tools			
Tool	Part Number	Part Description	Qty
A	-	E10 Torx Socket	1
B	27610306	Alignment Tool	1

Note: The crankshaft rear seal and the housing are manufactured as a one-piece assembly.

NOTICE

Keep all parts clean from contaminants.

Contaminants may cause rapid wear and shortened component life.

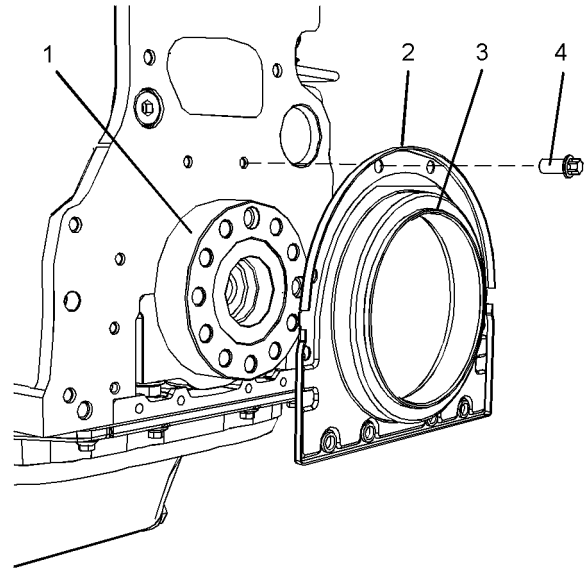

Illustration 103

g02717043

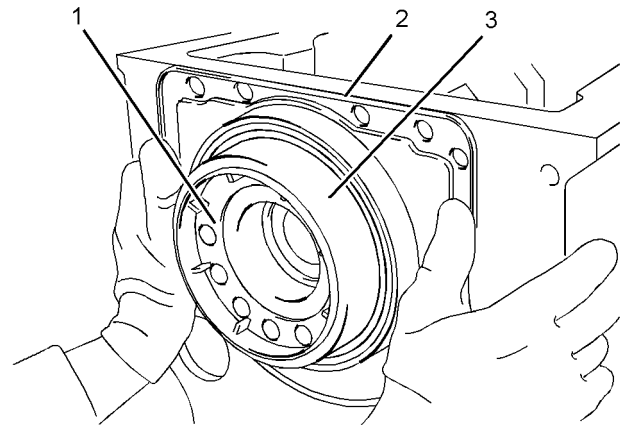

Illustration 104

g02717045

1. Ensure that crankshaft flange (1) is clean, dry, and free from damage.
2. Ensure that the face of the cylinder block and the bridge piece are clean and dry.
3. A new crankshaft rear seal is supplied with a plastic sleeve (3). Ensure that the plastic sleeve is squarely installed within crankshaft rear seal (2).

Note: The plastic sleeve is included in order to protect the lip of the seal as the seal is pushed over the crankshaft flange.

Note: Do not lubricate the crankshaft rear seal or the crankshaft flange. The crankshaft rear seal must be installed dry.

i04473009

4. Align plastic sleeve (3) with crankshaft flange (1). Ensure that the plastic sleeve is engaged onto the crankshaft flange. Push new crankshaft rear seal (2) squarely onto the crankshaft flange.

During this process, the plastic sleeve will be forced out of the crankshaft rear seal. Discard the plastic sleeve.

5. Ensure that crankshaft rear seal (2) is seated against the cylinder block.

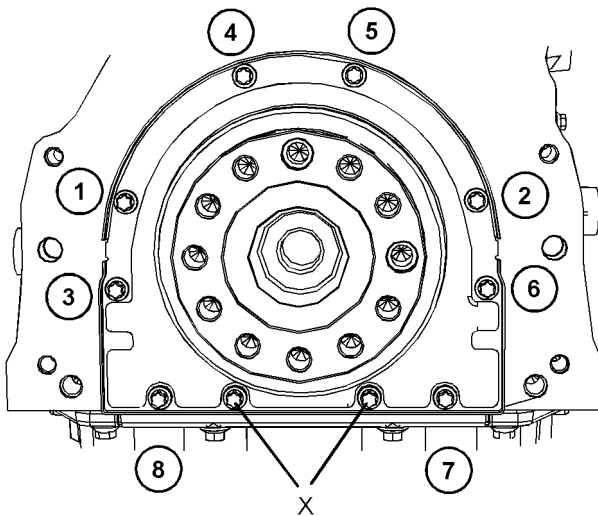

Illustration 105

g02717046

6. Install torx screws (4) finger tight.

Note: Do not install torx screws to Positions (X) at this stage.

7. Install Tooling (B) to crankshaft rear seal (2) and to crankshaft flange (1). Use Tooling (B) to align crankshaft rear seal (2) with crankshaft flange (1).
8. Use Tooling (A) in order to tighten torx screws (4) to a torque of 22 N·m (195 lb in). Tighten torx screws (4) in the sequence that is shown in Illustration 105.
9. Remove Tooling (B).
10. Install remaining torx screws (4) to Positions (X). Use Tooling (A) in order to tighten the torx screws to a torque of 22 N·m (195 lb in). Refer to Illustration 105.

End By:

- a. Install the flywheel. Refer to Disassembly and Assembly, "Flywheel - Install".

Flywheel Housing - Remove and Install (Standard Housing)

Removal Procedure

Table 31

Required Tools			
Tool	Part Number	Part Description	Qty
A	-	Guide Stud M10 by 100 mm	2

Start By:

- a. Remove the flywheel. Refer to Disassembly and Assembly, "Flywheel - Remove" for the correct procedure.

NOTICE

Keep all parts clean from contaminants.

Contaminants may cause rapid wear and shortened component life.

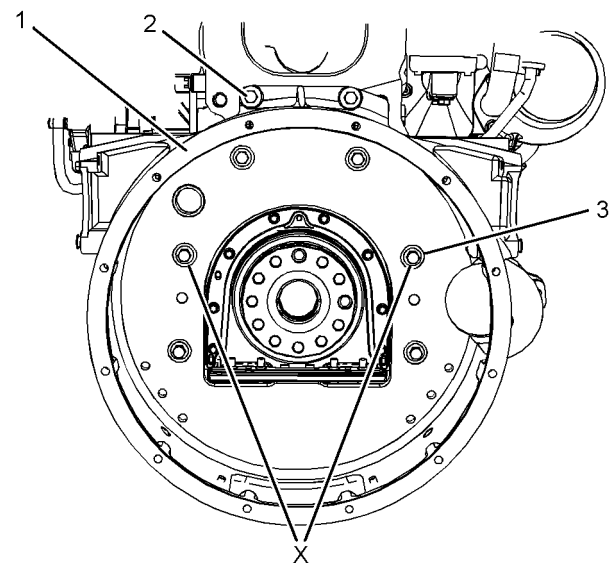

Illustration 106

g02227473

Typical example

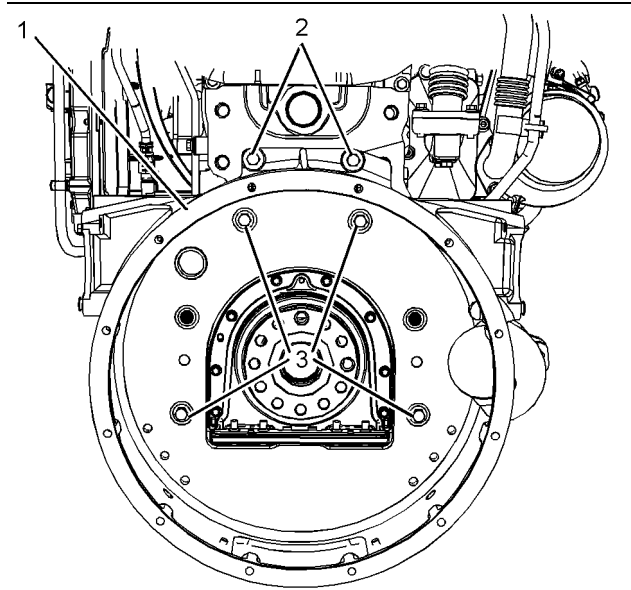

Illustration 107
Typical example g02227474

1. Remove bolts (3) from Position (X) from flywheel housing (1).
2. Install Tooling (A) into Position (X) on flywheel housing (1).
3. Install a suitable lifting device onto the flywheel housing in order to support the flywheel housing. The weight of the flywheel housing is approximately 40 kg (88 lb).
4. Remove bolts (2) and remaining bolts (3) from flywheel housing (1).
5. Use a suitable lifting device in order to remove flywheel housing (1) from the cylinder block.

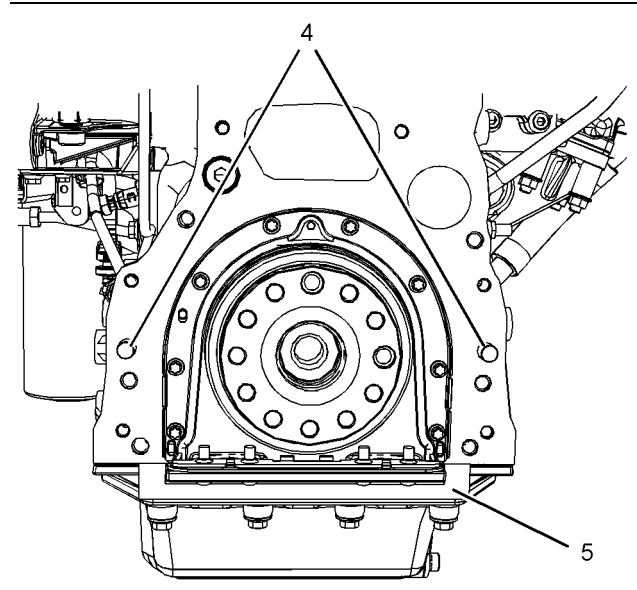

Illustration 108
Typical example g01983533

6. Remove dust seal (5).
7. If necessary, remove dowels (4) from the cylinder block.

Installation Procedure (Standard Housing)

Table 32

Required Tools			
Tool	Part Number	Part Description	Qty
A	-	Guide Stud M10 by 100 mm	2

NOTICE

Keep all parts clean from contaminants.

Contaminants may cause rapid wear and shortened component life.

1. Ensure that the flywheel housing is clean and free from damage. If necessary, replace the flywheel housing.

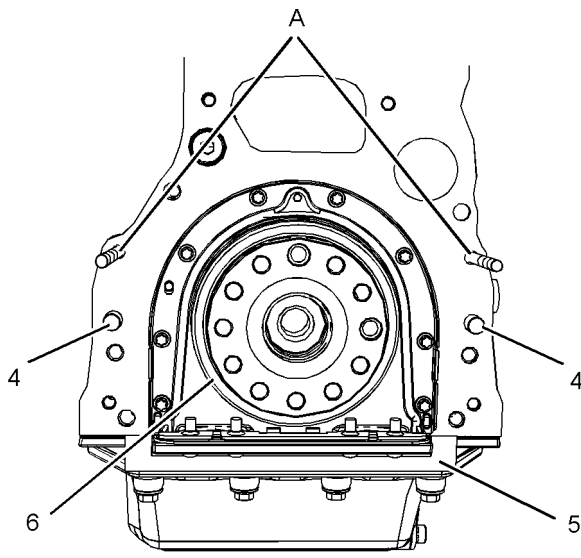

Illustration 109

g01983535

Typical example

2. Inspect crankshaft rear seal (6) for leaks. If there are any oil leaks, replace the crankshaft rear seal. Refer to Disassembly and Assembly, "Crankshaft Rear Seal - Remove" and refer to Disassembly and Assembly, "Crankshaft Rear Seal - Install" for the correct procedure.
3. Clean the rear face of the cylinder block. If necessary, install dowels (4) to the cylinder block.
4. Install Tooling (A) to the cylinder block.
5. Install dust seal (5).

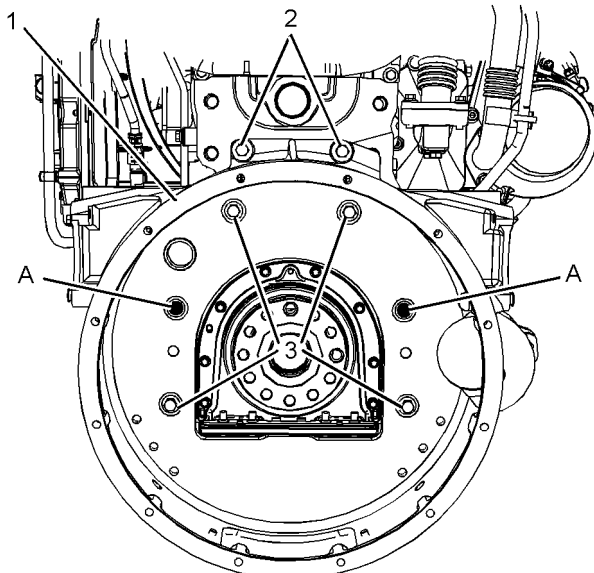

Illustration 110

g02227475

Typical example

6. Install a suitable lifting device onto the flywheel housing. The weight of the flywheel housing is approximately 40 kg (88 lb).
7. Use the lifting device to align flywheel housing (1) with Tooling (A). Install the flywheel housing to the cylinder block.
8. Install bolts (2) and bolts (3).
9. Remove Tooling (A). Install remaining bolts (3).

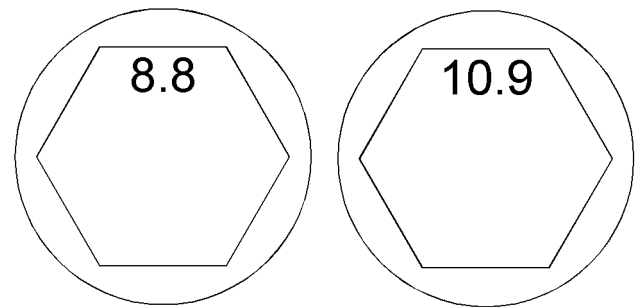

Illustration 111

g01984554

Identification of the bolt Grade.

10. When 8.8 Graded bolts are installed, follow Step 10.a through Step 10.b.
 - a. Tighten bolts (3) to a torque of 63 N·m (46 lb ft).
 - b. Tighten bolts (2) to a torque of 78 N·m (58 lb ft).
 11. When 10.9 Graded bolts are installed follow Step 11.a through Step 11.b.
 - a. Tighten bolts (3) to a torque of 115 N·m (85 lb ft).
 - b. Tighten bolts (2) to a torque of 190 N·m (140 lb ft).
 12. Check the alignment of flywheel housing (1) with the crankshaft. Refer to System Operation, Testing and Adjusting, "Flywheel Housing - Inspect" for more information.
- End By:**
- a. Install the flywheel. Refer to Disassembly and Assembly, "Flywheel - Install" for the correct procedure.

i04481819

Vibration Damper and Pulley - Remove

Removal Procedure

Table 33

Required Tools			
Tool	Part Number	Part Description	Qty
A	-	Guide Stud M14 x 1.5 by 100 mm	1
B	27610299	E18 Torx Socket	1

Start By:

- a. Remove the alternator belt. Refer to Disassembly and Assembly, "V- Belts - Remove and Install" for the correct procedure.

Note: The weight of the assembly of the crankshaft pulley, the vibration damper, and the crankshaft adapter is approximately 22 kg (48 lb).

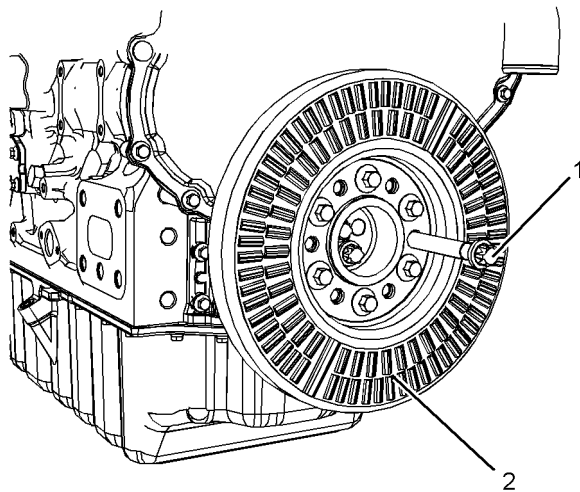

Illustration 112

g02717789

1. Use a suitable tool in order to prevent the crankshaft from rotating. Use Tooling (B) to remove one Torx screws (1) from crankshaft pulley assembly (2).
2. Install Tooling (A) into crankshaft pulley assembly (2).
3. Remove remaining Torx screws (1) from crankshaft pulley assembly (2).
4. Remove crankshaft pulley assembly (2).

5. Tooling (A).

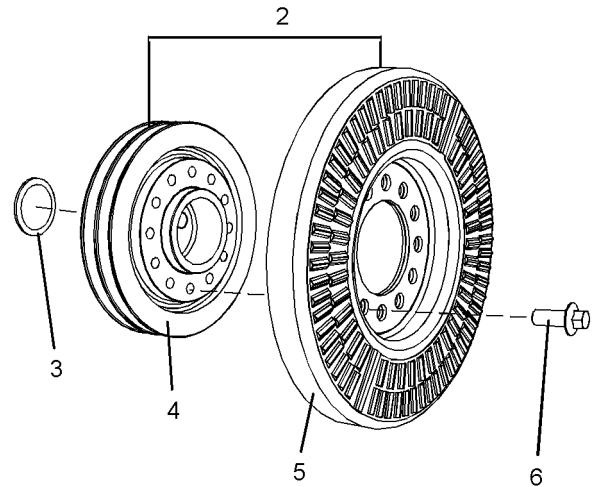

Illustration 113

g02717790

6. If necessary, follow Step 6.a through Step 6.b in order to remove friction shim (3) from the crankshaft.
 - a. Remove the front seal from the front cover. Refer to Disassembly and Assembly, "Crankshaft Front Seal - Remove and Install" for the correct procedure.
 - b. Remove friction shim (3).
7. If necessary, follow Step 7.a through Step 7.c in order to disassemble vibration damper, crankshaft pulley.
 - a. Place the crankshaft pulley assembly onto a suitable support.
 - b. Remove bolts (6) from crankshaft pulley assembly (2).
 - c. Remove vibration damper (5) from crankshaft pulley (5).

i04481820

Vibration Damper and Pulley - Install

Installation Procedure

Table 34

Required Tools			
Tool	Part Number	Part Description	Qty
A	-	Guide Stud M14x1.5 by 100 mm	1
B	27610299	E18 Torx Socket	1
C	21825607	Degree Wheel	1
D	-	Guide Studs M12x1.75 by 50 mm	2

NOTICE

Keep all parts clean from contaminants.

Contaminants may cause rapid wear and shortened component life.

1. Ensure that the crankshaft pulley and the front of the crankshaft are clean and free from damage.

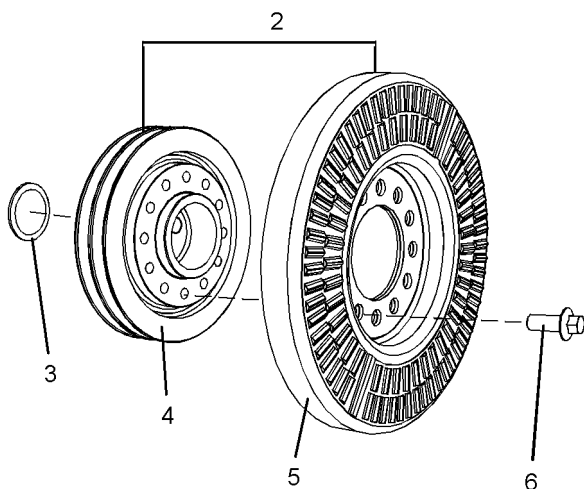

Illustration 114

g02717790

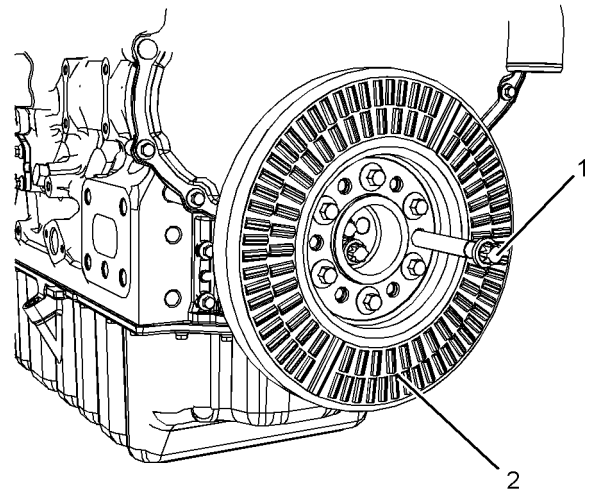

Illustration 115

g02717789

2. Inspect vibration damper (5) for damage. If necessary, replace the vibration damper.
3. If necessary, follow Step 3.a through Step 3.e in order to install vibration damper, crankshaft pulley to crankshaft adapter.
 - a. Place crankshaft pulley (4) onto a suitable support.
 - b. Install Tooling (D) crankshaft pulley (4).
 - c. Install vibration damper (6) over Tooling (D).
 - d. Install bolts (6) to the crankshaft pulley assembly.

Note: Evenly space bolts (6) around the crankshaft pulley assembly.

 - a. Tighten bolts (6) finger tight.
4. If necessary, install friction shim (3). Follow Step 4.a through Step 4.b in order to install friction shim (3).
 - a. Install friction shim (3).
 - b. Install a new front seal to the front cover. Refer to Disassembly and Assembly, "Crankshaft Front Seal - Remove and Install" for the correct procedure.
5. If the friction shim has not been removed, install a new front seal to the front cover. Refer to Disassembly and Assembly, "Crankshaft Front Seal - Remove and Install" for the correct procedure.
6. Install Tooling (A) to the crankshaft.

7. Install crankshaft pulley assembly (2) onto the crankshaft.

Note: Do not lubricate the front seal or the seal face of the crankshaft pulley assembly.

8. Install two Torx screws (1) to crankshaft pulley assembly (2) hand tighten.
9. Remove Tooling (A).
10. Install remaining Torx screws (1) to crankshaft pulley assembly (2).
11. Tighten bolts (6) to a torque of 115 N·m (85 lb ft).
12. Use a suitable tool in order to prevent the crankshaft from rotating. Tighten Torx screws (1) to a torque of 40 N·m (29 lb ft).
13. Use Tooling (B) and Tooling (C) to turn Torx screws (1) through an additional 120 degrees.

End By:

- a. Install the alternator belt. Refer to Disassembly and Assembly, "V-Belt - Remove and Install" for the correct procedure.

i04472960

Crankshaft Front Seal - Remove and Install

Removal Procedure

Table 35

Required Tools			
Tool	Part Number	Part Description	Qty
A	27610301	Front Oil Seal Removal Tool	1

Start By:

- a. Remove the vibration damper and crankshaft pulley. Refer to Disassembly and Assembly, "Vibration Damper and Pulley - Remove" for the correct procedure.

NOTICE

Keep all parts clean from contaminants.

Contaminants may cause rapid wear and shortened component life.

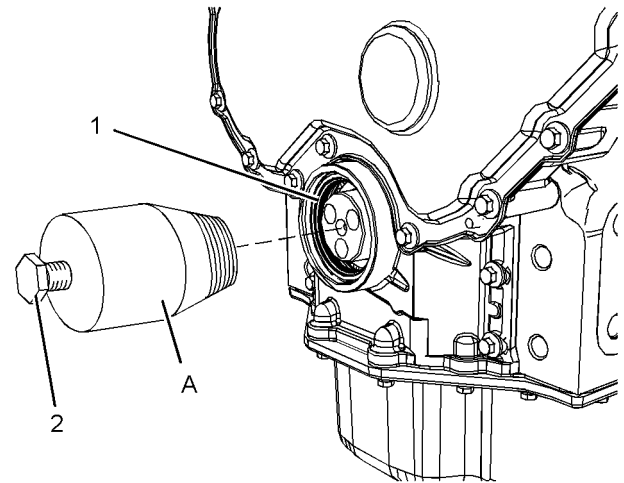

Illustration 116

g02728014

1. Position Tooling (A) on the nose of the crankshaft. Screw Tooling (A) into crankshaft front seal (1).

Note: Do not damage the edge of the housing for the crankshaft front seal.

2. Screw bolt (2) into Tooling (A) in order to remove crankshaft front seal (1).

Installation Procedure

Table 36

Required Tools			
Tool	Part Number	Part Description	Qty
B	21825577	Front Seal Installer	1
	21825578	Plate	1
	T400029	Anchor Plate	1
	27610284	Seal Installer Tool	1
	21825579	Sleeve	1

NOTICE

Keep all parts clean from contaminants.

Contaminants may cause rapid wear and shortened component life.

1. Ensure that the bore for the crankshaft front seal in the front housing is clean and free from damage.

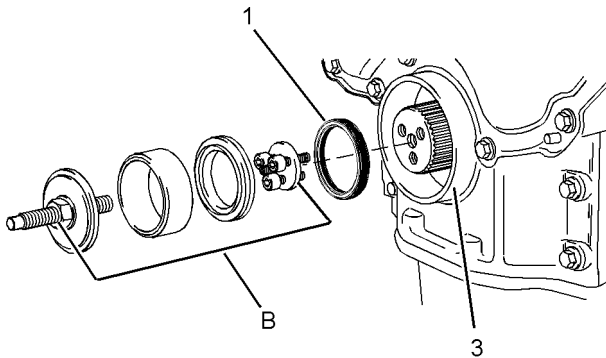

Illustration 117

g02704637

2. Assemble Tooling (B).

3. Align new crankshaft front seal (1) to front housing (4).

Note: If the crankshaft front seal is supplied with a sleeve, remove the sleeve from the crankshaft front seal before installation.

4. Use Tooling (B) to install crankshaft front seal (1). Ensure that the front face of the seal is installed to a depth of 6.5 ± 0.2 mm (0.256 ± 0.008 inch) into front housing (4).

5. Remove Tooling (B) from the crankshaft.

End By:

a. Install the vibration damper and crankshaft pulley. Refer to Disassembly and Assembly, "Vibration Damper and Pulley - Install" for the correct procedure.

i04473010

Front Cover - Remove and Install

Removal Procedure

Start By:

a. If the engine has a fan, remove the fan and pulleys. Refer to Disassembly and Assembly, "Fan - Remove and Install" for the correct procedure.

b. Remove the vibration damper and pulley assembly. Refer to Disassembly and Assembly, "Vibration Damper and Pulley - Remove" for the correct procedure.

c. Remove the water pump. Refer to Disassembly and Assembly, "Water Pump - Remove" for the correct procedure.

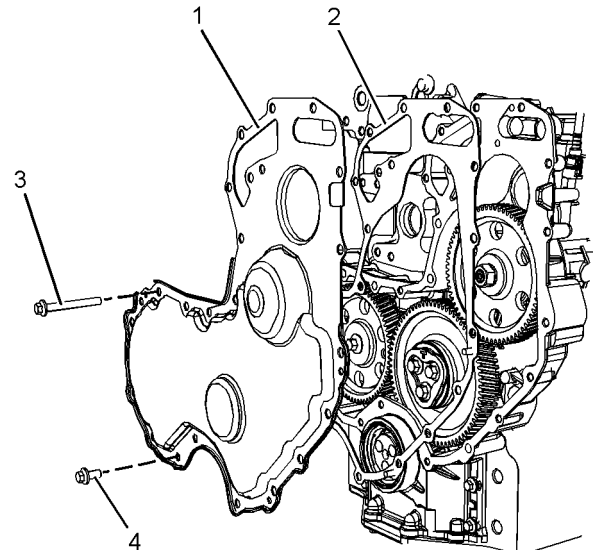

Illustration 118

g02706916

1. Remove bolts (3) and bolts (4). Identify the positions of the different length bolts.

2. Remove front cover (1) from the front housing.

3. Remove gasket (2) from front cover (1).

Installation Procedure

Table 37

Required Tools			
Tool	Part Number	Part Description	Qty
A	-	Guide Stud (M8 by 70 mm)	2

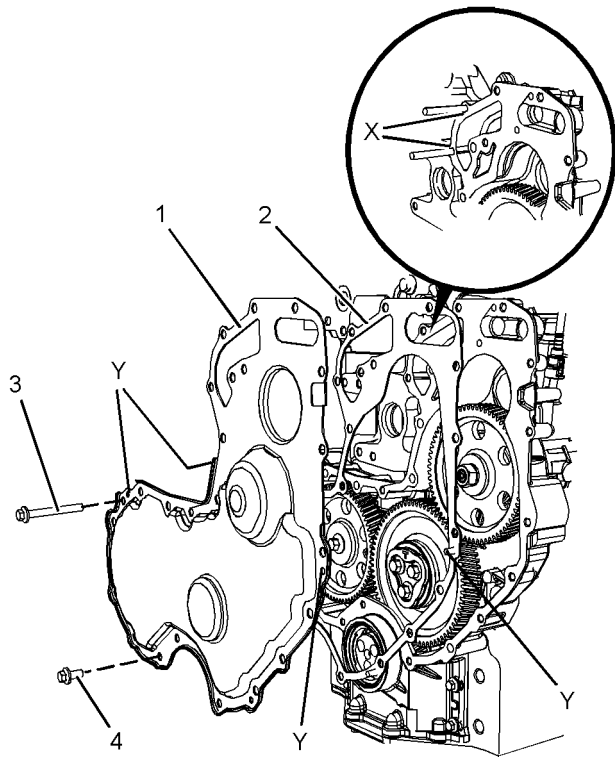

Illustration 119

g02706917

1. Thoroughly clean the gasket surface of the front housing.
2. If the original front cover is installed, follow Step 2.a through Step 2.b.
 - a. Thoroughly clean front cover (1).
 - b. Install a new gasket (2) to front cover (1). Engage three Locators (Y) (not shown) into the holes in the front cover.
3. Install Tooling (A) into Holes (X) in the front housing.
4. Use Tooling (A) in order to position the front cover assembly onto the front housing.
5. Install bolts (3) and bolts (4) finger tight. Ensure that the different length bolts are installed in the correct positions.
6. Loosely install the water pump assembly and remove Tooling (A). Refer to Disassembly and Assembly, "Water Pump - Install" for the correct procedure.
7. Tighten bolts (3) and bolts (4) to a torque of 22 N·m (195 lb in).

8. Tighten the bolts for the water pump to a torque of 22 N·m (195 lb in). Refer to Disassembly and Assembly, "Water Pump - Install" for the correct tightening sequence.

End By:

- a. If the engine has a fan, install the fan and pulleys. Refer to Disassembly and Assembly, "Fan - Remove and Install" for the correct procedure.
- b. Install the vibration damper and pulley assembly. Refer to Disassembly and Assembly, "Vibration Damper and Pulley - Install" for the correct procedure.

i04473051

Gear Group (Front) - Remove and Install

Removal Procedure

Table 38

Required Tools			
Tool	Part Number	Part Description	Qty
A ⁽¹⁾	T400011	Crankshaft Turning Tool	1
A ⁽²⁾	27610291	Housing	1
	27610289	Engine Turning Tool	1
B	27610212	Timing Pin (Camshaft)	1
C	27610286	Timing Pin (Crankshaft)	1

⁽¹⁾ The Crankshaft Turning Tool is used on the front pulley.

⁽²⁾ This Tool is used in the aperture for the electric starting motor.

Start By:

- a. Remove the front cover. Refer to Disassembly and Assembly, "Front Cover - Remove and Install" for the correct procedure .
- b. Remove the valve mechanism cover. Refer to Disassembly and Assembly, "Valve Mechanism Cover - Remove and Install" for the correct procedure .

NOTICE

Keep all parts clean from contaminants.

Contaminants may cause rapid wear and shortened component life.

NOTICE

Care must be taken to ensure that fluids are contained during performance of inspection, maintenance, testing, adjusting and repair of the product. Be prepared to collect the fluid with suitable containers before opening any compartment or disassembling any component containing fluids.

Dispose of all fluids according to local regulations and mandates.

Note: Either Tooling (A) can be used. Use the Tooling that is most suitable.

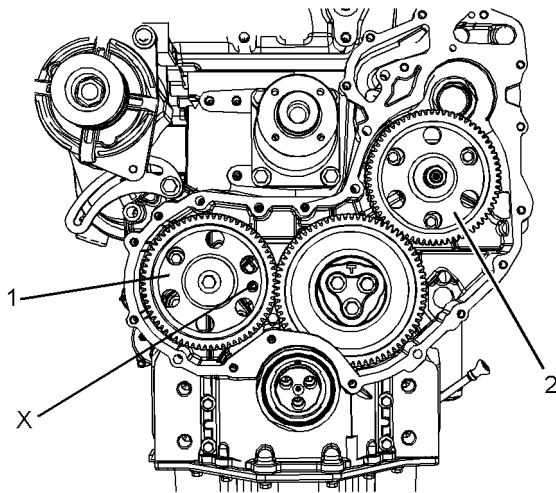

Illustration 120

g02706996

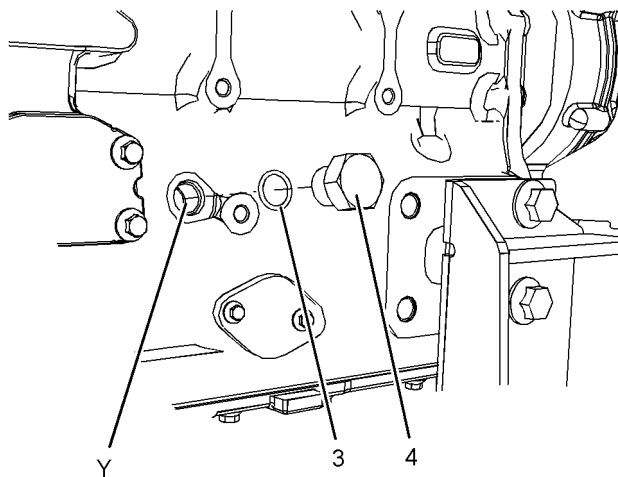

Illustration 121

g02695979

1. Care must be taken in order to ensure that the fuel injection pump timing is not lost during the removal of the front gear group. Carefully follow the procedure in order to remove the gear group.
2. Remove plug (4) from the cylinder block. Remove O-ring seal (3) from plug (4).
3. Use Tooling (A) in order to rotate the crankshaft so that number one piston is at top dead center on the compression stroke. Refer to System Operation, Testing and Adjusting, "Finding Top Center Position for No.1 Piston" for the correct procedure.
4. Install Tooling (B) through Hole (X) in camshaft gear (1) into the front housing. Use Tooling (B) in order to lock the camshaft in the correct position.
5. Install Tooling (C) into Hole (Y) in the cylinder block. Use Tooling (C) in order to lock the crankshaft in the correct position.

Note: Do not use excessive force to install Tooling (C). Do not use Tooling (C) to hold the crankshaft during repairs.

6. Apply sufficient pressure to fuel injection pump gear (2) in a counterclockwise direction in order to remove the backlash. Lock the fuel injection pump in this position. Refer to Disassembly and Assembly, "Fuel Pump Gear - Remove" for the correct procedure.

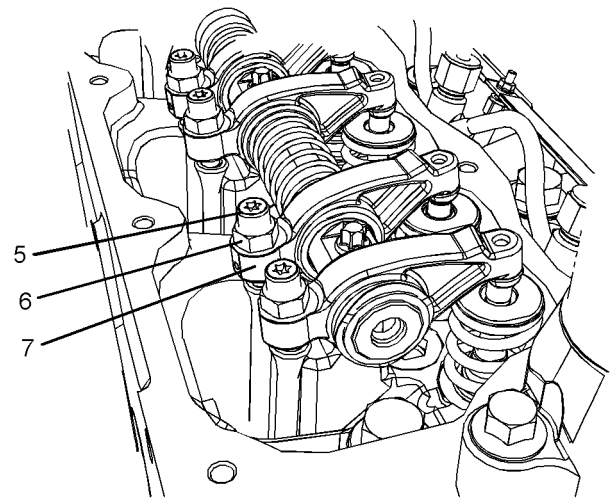

Illustration 122

g02707118

7. Loosen nuts (6) on all rocker arms (7). Unscrew adjusters (5) on all rocker arms (7) until all valves are fully closed.

Note: Failure to ensure that ALL adjusters are fully unscrewed can result in contact between the valves and pistons.

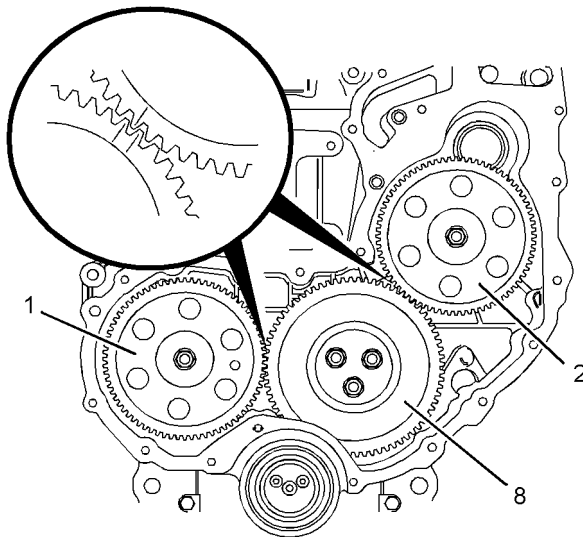

Illustration 123
Alignment of timing marks
g02706997

8. Mark gear (1), gear (2), and gear (8) in order to show alignment. Refer to Illustration 123.

Note: Identification will ensure that the gears can be installed in the original alignment.

9. Remove fuel pump gear (2). Refer to Disassembly and Assembly, "Fuel Pump Gear - Remove and Install" for the correct procedure.

10. Remove camshaft gear (1). Refer to Disassembly and Assembly, "Camshaft Gear - Remove and Install" for the correct procedure.

11. Remove idler gear (8). Refer to Disassembly and Assembly, "Idler Gear - Remove and Install" for the correct procedure.

Installation Procedure

Table 39

Required Tools			
Tool	Part Number	Part Description	Qty
A ⁽¹⁾	T400011	Crankshaft Turning Tool	1
A ⁽²⁾	27610291	Housing	1
	27610289	Engine Turning Tool	1
C	27610286	Timing Pin (Crankshaft)	1
B	27610212	Timing Pin (Camshaft)	1
D	21825496	Indicator Bracket	1
	21825617	Dial Indicator	1
	-	Indicator Contact Point	1
	-	Universal Attachment	1

(1) The Crankshaft Turning Tool is used on the front pulley.

(2) This Tool is used in the aperture for the electric starting motor.

NOTICE

Keep all parts clean from contaminants.

Contaminants may cause rapid wear and shortened component life.

Note: The fuel injection pump must remain locked until the procedure instructs you to unlock the fuel injection pump.

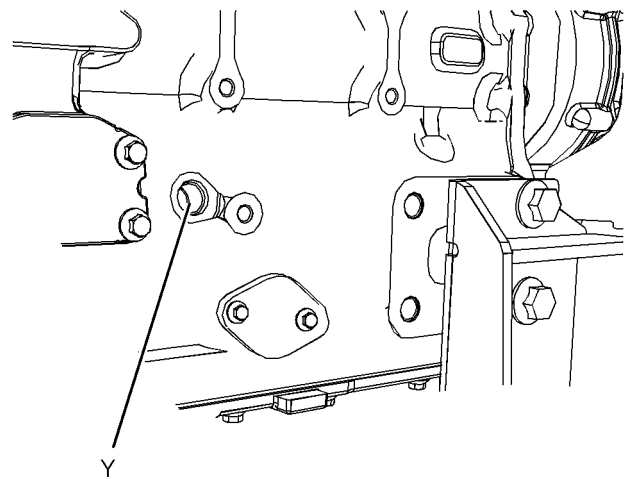

Illustration 124

g02706999

1. If necessary, use Tooling (A) to ensure that number one piston is at top dead center on the compression stroke. Refer to System Operation, Testing and Adjusting, "Finding Top Center Position for No.1 Piston" for the correct procedure.
2. Ensure that Tooling (C) is installed in Hole (Y) in the cylinder block. Use Tooling (C) in order to lock the crankshaft in the correct position.

Note: Do not use excessive force to install Tooling (C). Do not use Tooling (C) to hold the crankshaft during repairs.

3. Ensure that all of the components of the front gear group are clean and free from wear or damage. If necessary, replace any components that are worn or damaged.

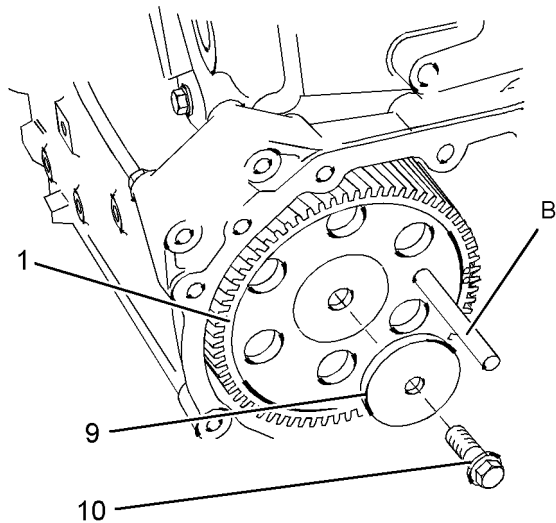

Illustration 125 g02707196

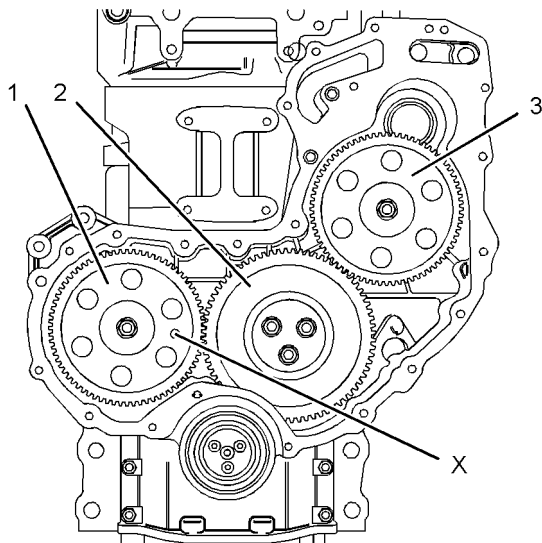

Illustration 126 g02707197

4. Install camshaft gear (1). Loosely install bolt (10) and washer (9) for the camshaft gear. Refer to Disassembly and Assembly, "Camshaft Gear - Remove and Install" for the correct procedure.
5. Install Tooling (B) through Hole (X) in camshaft gear (1) into the front housing.

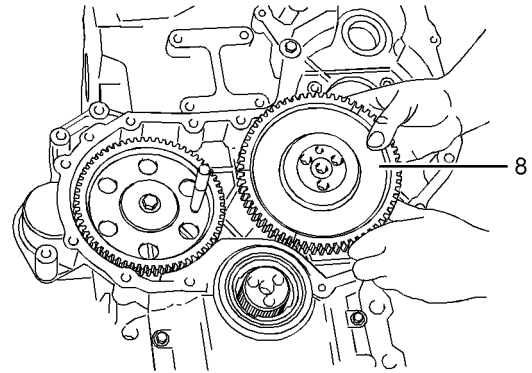

Illustration 127 g02707198

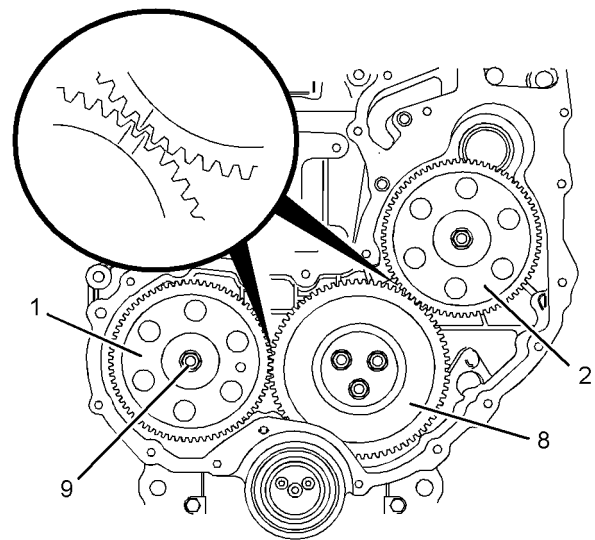

Illustration 128 g02707236

Alignment of timing marks

6. Install idler gear (8). Ensure that the timing mark on gear (1) and the timing mark on gear (8) are aligned. Ensure that the mesh of the gears is correct. Tighten the bolts for idler gear (8) to a torque of 44 N·m (32 lb ft). Refer to Disassembly and Assembly, "Idler Gear - Remove and Install" for the correct procedure.
7. When bolt (9) is a 8.8 Grade. Tighten bolt (10) to a torque of 95 N·m (70 lb ft).

When bolt (9) is a 10.9 Grade. Tighten bolt (10) to a torque of 120 N·m (89 lb ft).

8. Ensure that the fuel injection pump is locked in the correct position. Refer to Disassembly and Assembly, "Fuel Injection Pump - Install" for the correct procedure.
9. Install fuel injection pump gear (2). Ensure that the timing marks on gear (2) and the timing marks on gear (8) are aligned. See Illustration 128. Ensure that the mesh of the gears is correct. Refer to Disassembly and Assembly, "Fuel Injection Pump Gear - Install" for more information.
10. Remove Tooling (B) and Tooling (C).
11. Use Tooling (D) in order to measure the end play of camshaft gear (1). Refer to Specifications, "Camshaft" for more information.
12. Use Tooling (D) in order to measure the backlash for gear (1), gear (2) and gear (8) is within specified values. Refer to Specifications, "Gear Group (Front)" for further information.
13. Adjust the engine valve lash. Refer to System Operation, Testing and Adjusting, "Engine Valve Lash - Inspect/Adjust" for the correct procedure.

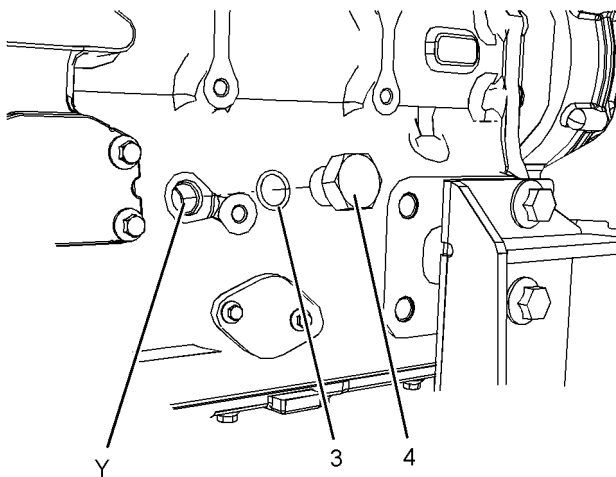

Illustration 129

g02707000

14. Install a new O-ring seal (3) to plug (4). Install plug (4) to the cylinder block. Tighten locking bolt (5) against the spacer to a torque of 21 N·m (186 lb in).
15. Lubricate each gear with clean engine oil.

End By:

- a. Install the front cover. Refer to Disassembly and Assembly, "Front Cover - Remove and Install" for the correct procedure.

- b. Install the front cover. Refer to Disassembly and Assembly, "Front Cover - Remove and Install" for the correct procedure.

i04473057

Idler Gear - Remove

Removal Procedure

Table 40

Required Tools			
Tool	Part Number	Part Description	Qty
A ⁽¹⁾	T400011	Crankshaft Turning Tool	1
A ⁽²⁾	27610291	Housing	1
	27610289	Engine Turning Tool	1
B	27610286	Timing Pin (Crankshaft)	1
C	27610212	Timing Pin (Camshaft)	1

(1) The Crankshaft Turning Tool is used on the front pulley.

(2) This Tool is used in the aperture for the electric starting motor.

Start By:

- a. Remove the fuel injection pump gear. Refer to Disassembly and Assembly, "Fuel Pump Gear - Remove".
- b. Remove the valve mechanism cover. Refer to Disassembly and Assembly, "Valve Mechanism Cover - Remove and Install".

Note: Either Tooling (A) can be used. Use the Tooling that is most suitable.

Note: Care must be taken in order to ensure that the fuel injection pump timing is not lost during the removal of the fuel pump gear. Carefully follow the procedure in order to remove the fuel pump gear.

NOTICE

Keep all parts clean from contaminants.

Contaminants may cause rapid wear and shortened component life.

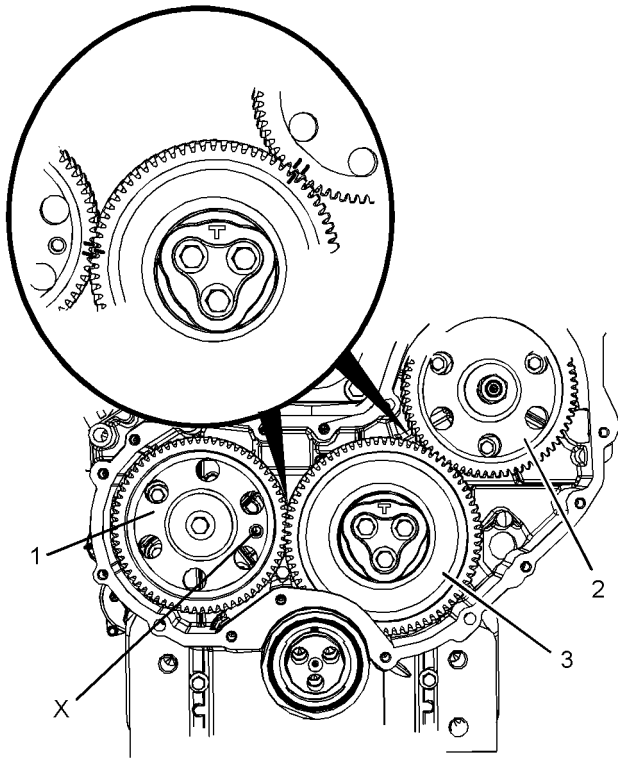

Illustration 130

g02712440

Alignment of timing marks

3. Install Tooling (B) into Hole (Y) in the cylinder block. Use Tooling (B) in order to lock the crankshaft in the correct position.

Note: Do not use excessive force to install Tooling (B). Do not use Tooling (B) to hold the crankshaft during repairs.

4. Ensure that Tooling (C) is installed into Hole (X) in the camshaft gear. Use Tooling (C) in order to lock the camshaft in the correct position.
5. Ensure that gear (1), gear (2), and gear (3) are marked in order to show alignment.

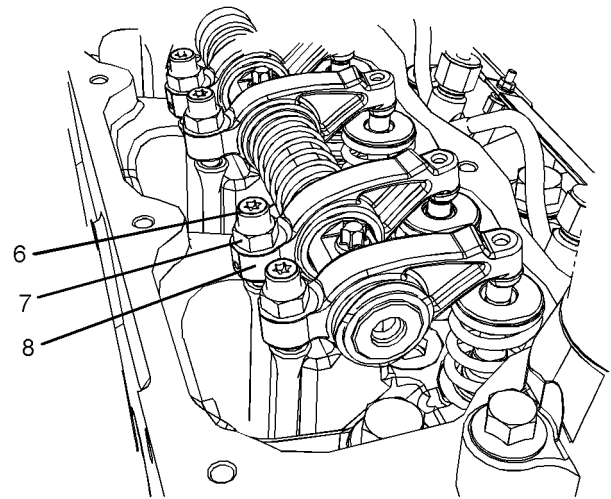

Illustration 132

g02712442

6. Loosen nuts (7) on all rocker arms (8). Unscrew adjusters (6) on all rocker arms (8) until all valves are fully closed.

Note: Failure to ensure that ALL adjusters are fully unscrewed can result in contact between the valves and pistons.

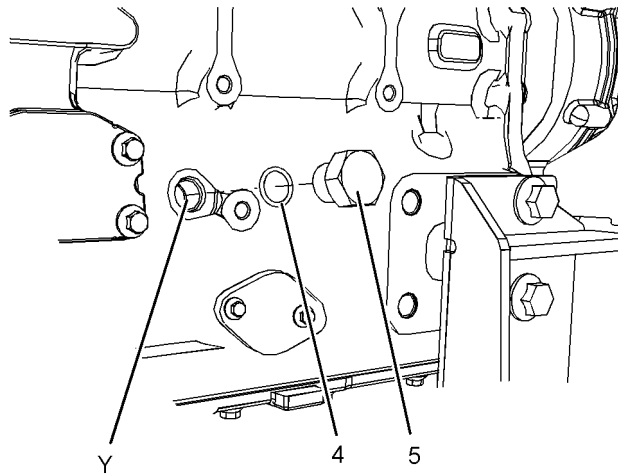

Illustration 131

g02712439

1. Remove plug (5) from the cylinder block. Remove O-ring seal (4) from plug (5).
2. Use Tooling (A) in order to rotate the crankshaft so that number one piston is at top dead center on the compression stroke. Refer to System Operation, Testing and Adjusting, "Finding Top Center Position for No.1 Piston".

i04473056

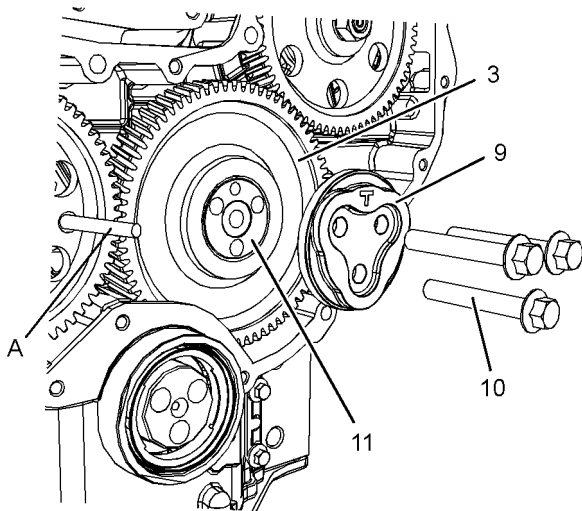

Illustration 133

g02712444

7. Mark plate (9) in order to show orientation.

Note: Identification will ensure that the plate can be installed in the original orientation.

8. Remove bolts (10).

9. Remove plate (9).

10. Remove the assembly of idler gear (3) and hub (11) from the recess in the front housing.

Note: The idler gear must be tilted during removal.

11. Remove hub (11) from idler gear (3).

Idler Gear - Install

Installation Procedure

Table 41

Required Tools			
Tool	Part Number	Part Description	Qty
A ⁽¹⁾	T400011	Crankshaft Turning Tool	1
A ⁽²⁾	27610291	Housing	1
	27610289	Engine Turning Tool	1
B	27610286	Timing Pin (Crankshaft)	1
C	27610212	Timing Pin (Camshaft)	1
D	21825496	Indicator Bracket	1
	21825617	Dial Indicator	1
	-	Indicator Contact Point	1
	-	Universal Attachment	1

(1) The Crankshaft Turning Tool is used on the front pulley.

(2) This Tool is used in the aperture for the electric starting motor.

NOTICE

Keep all parts clean from contaminants.

Contaminants may cause rapid wear and shortened component life.

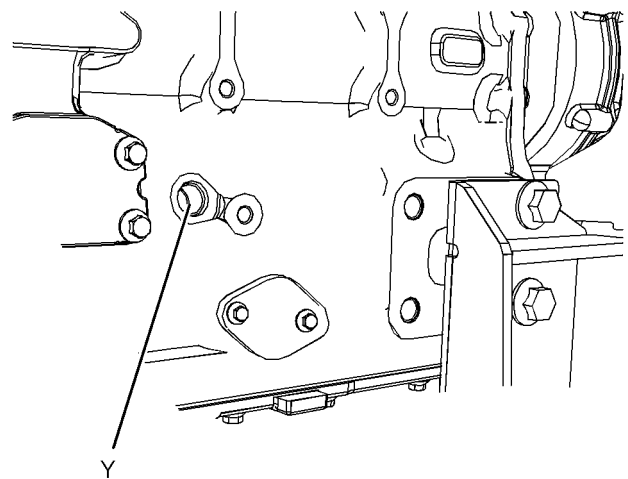

Illustration 134

g02717945

1. If necessary, use Tooling (A) to ensure that number one piston is at top dead center on the compression stroke. Refer to System Operation, Testing and Adjusting, "Finding Top Center Position for No.1 Piston" for the correct procedure.
2. Ensure that Tooling (B) is installed in Hole (Y) in the cylinder block. Use Tooling (B) in order to lock the crankshaft in the correct position.

Note: Do not use excessive force to install Tooling (B). Do not use Tooling (B) to hold the crankshaft during repairs.

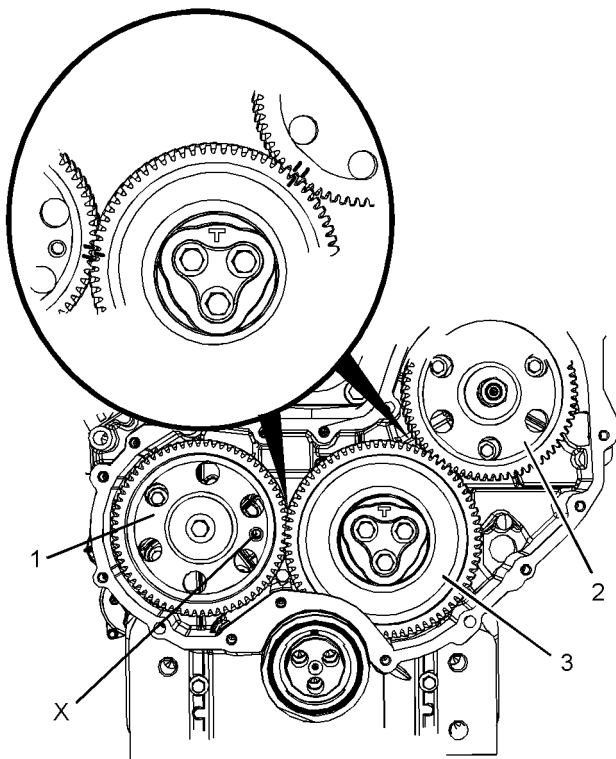

Illustration 135

g02712440

Alignment of timing marks

3. Ensure that Tooling (C) is installed into Hole (X) in camshaft gear (1).

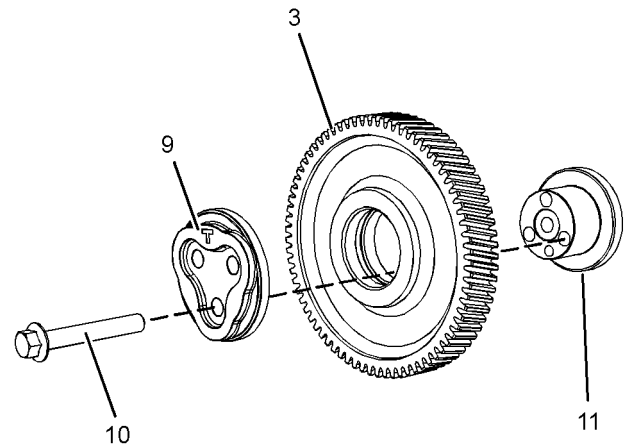

Illustration 136

g02718564

4. Clean idler gear (3) and inspect the idler gear for wear or damage. Refer to Specifications, "Gear Group (Front)" for more information. If necessary, replace the idler gear.
5. Clean hub (11) and inspect the hub for wear or damage. Refer to Specifications, "Gear Group (Front)" for more information. If necessary, replace the hub.
6. Lubricate hub (11) with clean engine oil. Slide hub (11) into idler gear (3). Ensure that the timing marks are toward the front of the idler gear.

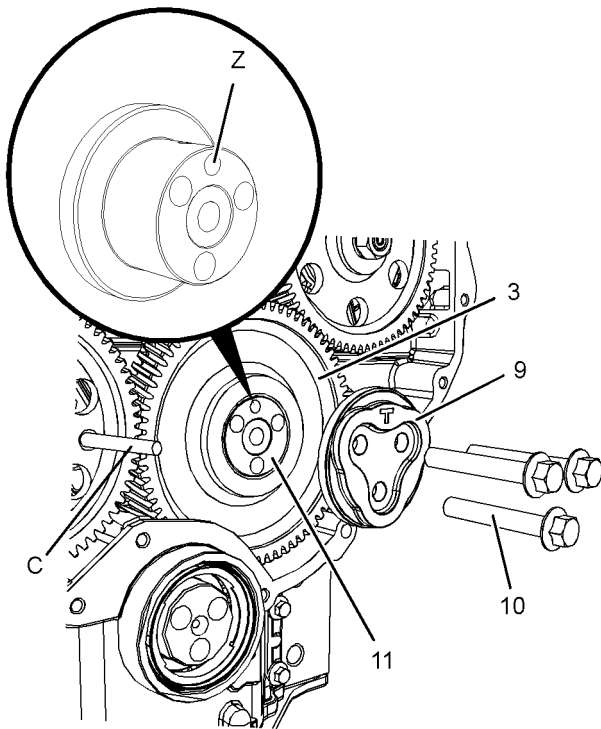

Illustration 137

g02718572

7. Align the timing mark on idler gear (3) with the timing mark on the camshaft gear. Refer to the illustration 135. Install the assembly of idler gear (3) and hub (11) into the recess in the timing case. Ensure that oil Hole (Z) is to the top of the hub.

Note: The idler gear must be tilted during installation. Ensure that the holes in the hub are aligned with the holes in the cylinder block.

- 8. Clean plate (9) and inspect the plate for wear or damage. If necessary, replace the plate.
- 9. Lubricate plate (9) with clean engine oil. Align the holes in plate (9) with the holes in hub (11). Install the plate in the original orientation.
- 10. Install bolts (10).
- 11. Remove Tooling (B) and Tooling (C).

Note: Ensure that timing marks are aligned, before removing Tooling (B) and Tooling (C).

12. Tighten bolts (10) to a torque of 44 N·m (32 lb ft).

13. Use Tooling (D) in order to measure the end play of the camshaft gear. Refer to Specifications, "Gear Group (Front)" for more information.

14. Use Tooling (D) in order to measure the backlash between the idler gear and the camshaft gear. Refer to Specifications, "Gear Group (Front)" for more information.

15. Use Tooling (D) in order to measure the backlash between the idler gear and the crankshaft gear. Refer to Specifications, "Gear Group (Front)" for more information.

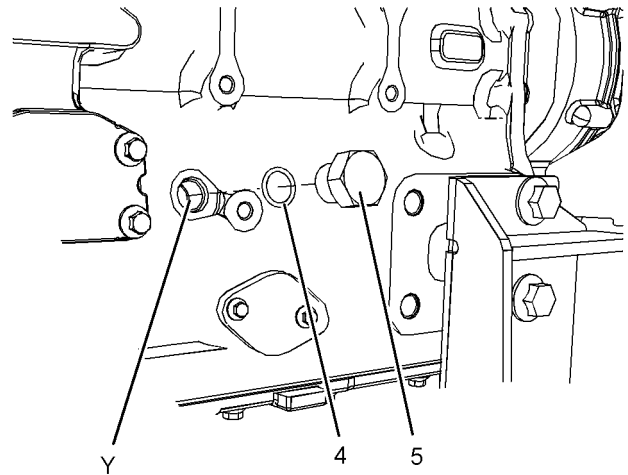

Illustration 138

g02712439

16. Install a new O-ring seal (4) to plug (5). Install plug (5) to the cylinder block. Tighten plug (5) to a torque of 21 N·m (186 lb in).

17. Lightly lubricate all of the gears with clean engine oil.

End By:

- a. Install the fuel injection pump gear. Refer to Disassembly and Assembly, "Fuel Pump Gear - Install".
- b. Adjust the engine valve lash. Refer to System Operation, Testing and Adjusting, "Engine Valve Lash - Inspect/Adjust" for the correct procedure.

i04473055

Housing (Front) - Remove

Removal Procedure

Start By:

- a. Remove the fan and pulley. Refer to Disassembly and Assembly, "Fan - Remove and Install".

- b. If necessary, remove the alternator. Refer to Disassembly and Assembly, "Alternator - Remove".
- c. Remove the front pulley. Refer to Disassembly and Assembly, "Vibration Damper and Pulley - Remove".
- d. Remove the engine oil pan. Refer to Disassembly and Assembly, "Engine Oil Pan - Remove".
- e. If the engine has an accessory drive, remove the accessory drive. Refer to Disassembly and Assembly, "Accessory Drive - Remove and Install".
- f. Drain the coolant into a suitable container for storage or disposal. Refer to Operation and Maintenance Manual, "Cooling System Coolant - Drain" for the correct procedure.
- g. Remove the timing gears. Refer to Disassembly and Assembly, "Gear Group (Front) - Remove and Install".
- h. Remove the fuel injection pump. Refer to Disassembly and Assembly, "Fuel Injection Pump - Remove".

NOTICE

Keep all parts clean from contaminants.

Contaminants may cause rapid wear and shortened component life.

NOTICE

Care must be taken to ensure that fluids are contained during performance of inspection, maintenance, testing, adjusting and repair of the product. Be prepared to collect the fluid with suitable containers before opening any compartment or disassembling any component containing fluids.

Dispose of all fluids according to local regulations and mandates.

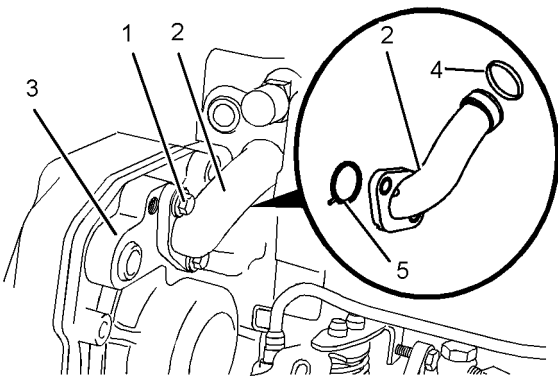

Illustration 139

g01337982

1. Remove bolts (1) that secure bypass tube (2) to front housing (3). Remove bypass tube (2) from the cylinder head. Remove O-ring (4) and O-ring (5) from bypass tube (2).

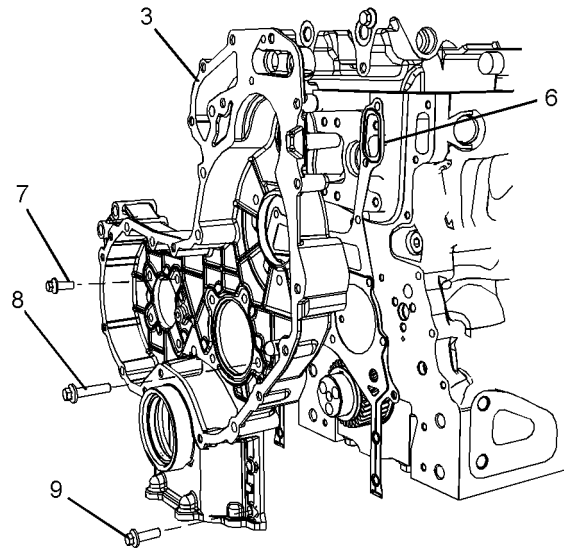

Illustration 140

g02718646

2. Remove bolts (7), bolts (8), and bolts (9) from front housing (3).

Note: The bolts are three different lengths. Note the positions of the different bolts.

3. Remove front housing (3) from the cylinder block.

4. Remove gasket (6).

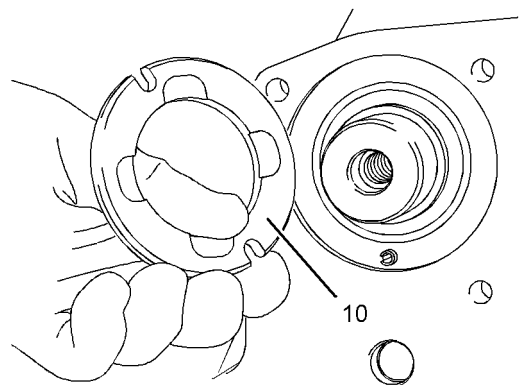

Illustration 141

g01337987

5. If necessary, remove thrust washer (10) from the cylinder block.

i04473053

Housing (Front) - Install

Installation Procedure

Table 42

Required Tools			
Tool	Part Number	Part Description	Qty
A	-	Loctite 575 Sealant	1
B	-	Guide Studs (M8 by 70 mm)	2
C	27610216	Alignment Tool	1
	-	studs (M10 by 50 mm)	3
D	-	Straight Edge	1
E	-	Delphi Lockheed Rubber Grease	1

NOTICE

Keep all parts clean from contaminants.

Contaminants may cause rapid wear and shortened component life.

1. Ensure that the front housing is clean and free from damage. If necessary, replace the front housing.

Install blanking plugs to a new front housing. Use Tooling (A) to seal all D-plugs.

2. Clean all the gasket surfaces of the cylinder block.

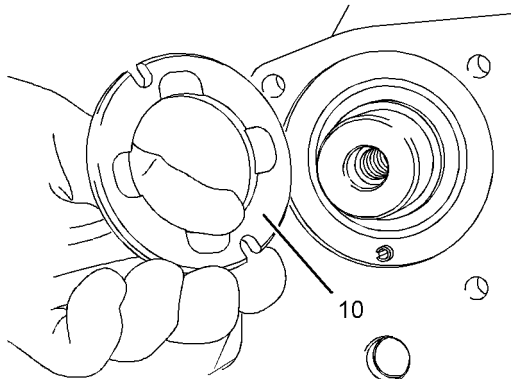

Illustration 142

g01337987

3. If necessary, install thrust washer (10) into the recess in the cylinder block. Refer to Disassembly and Assembly, "Camshaft - Install" for more information.

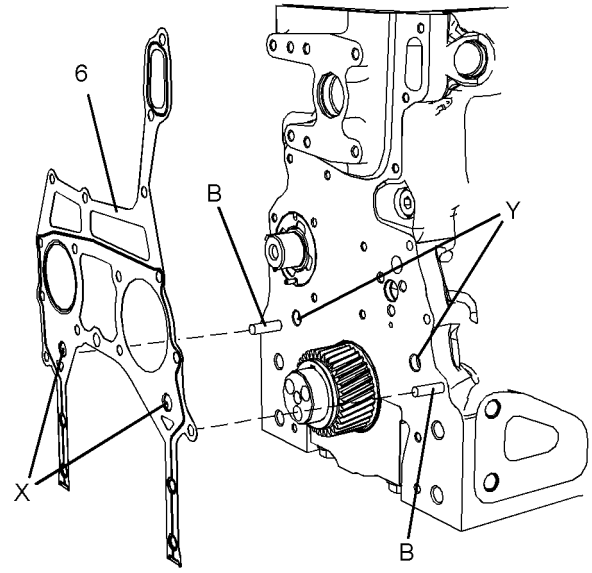

Illustration 143

g02718660

4. Install Tooling (B) to the cylinder block. Refer to Illustration 143.

5. Align a new gasket (6) with Tooling (B). Install the joint to the cylinder block.

Note: Ensure that two circular Tabs (X) on the gasket are engaged in two Holes (Y) in the cylinder block.

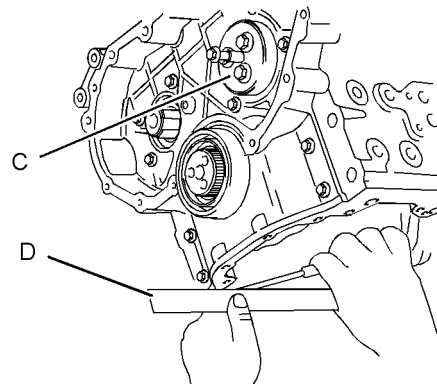

Illustration 144

g01338001

Typical example

6. Install Tooling (C) to the cylinder block.

7. Install the front housing over Tooling (B) and Tooling (C) onto the cylinder block.

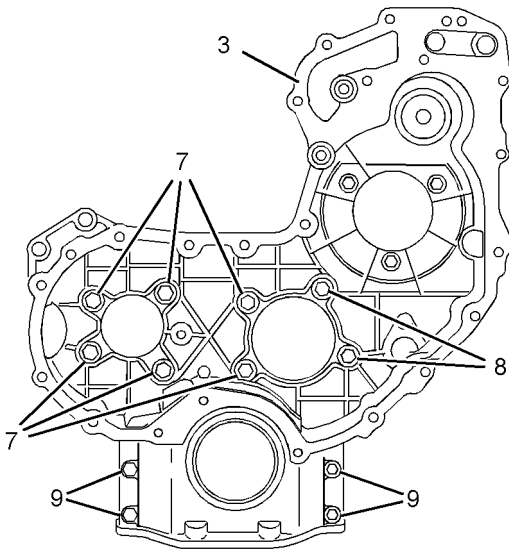

Illustration 145

g01338002

- (7) M8 by 20 mm
- (8) M8 by 35 mm
- (9) M8 by 25 mm

8. Install new bolts (9) to front housing (3) hand tight.
9. Remove Tooling (B).
10. Loosely install bolts (7) and bolts (8). Refer to Illustration 145 for the correct position of the bolts.
11. Align the bottom face of front housing (3) to the lower machined face of the cylinder block. Use Tooling (D) and a feeler gauge in order to check the alignment between the front housing and the cylinder block. Refer to Illustration 144. Refer to Specifications, "Front Housing and Covers" for further information.
12. Tighten bolts (9) in the sequence that is shown in illustration 146 to a torque of 28 N·m (248 lb in).
13. Repeat Step 11 to ensure that the bottom face of front housing (3) to the lower machined face of the cylinder block are still aligned.

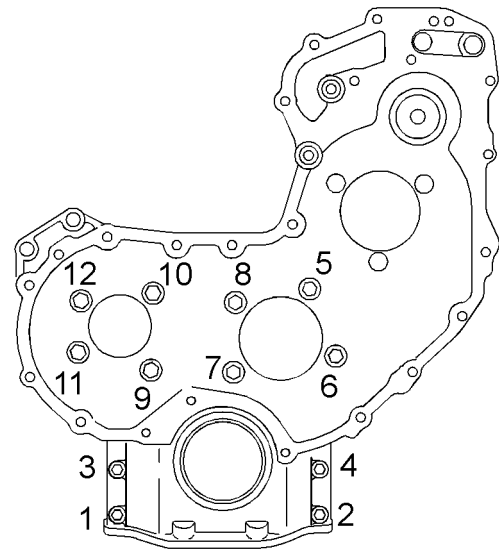

Illustration 146

g01338003

14. Tighten bolts (7), bolts (8) in the sequence that is shown in illustration 146 to a torque of 28 N·m (248 lb in).

Note: Ensure that the housing and the cylinder block are correctly aligned.

15. Remove Tooling (C) from the cylinder block.

16. Install a new crankshaft front seal. Refer to Disassembly and Assembly, "Crankshaft Front Seal - Remove and Install".

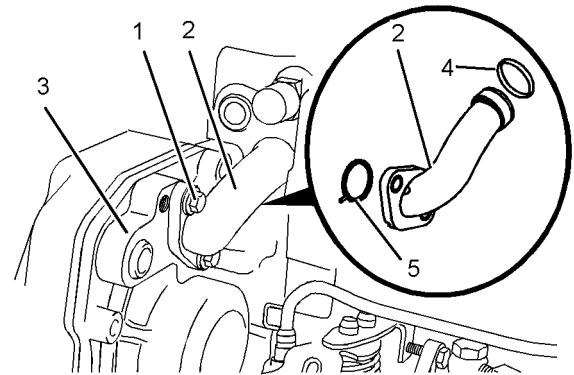

Illustration 147

g01337982

Typical example

17. Install new O-ring seal (4) and new O-ring seal (5) to bypass tube (2). Use Tooling (E) in order to lubricate the O-ring seals. Install bypass tube (2) to the cylinder head. Install bolts (1). Tighten the bolts to a torque of 22 N·m (195 lb in).

End By:

- a. Install the fuel injection pump. Refer to Disassembly and Assembly, "Fuel Injection Pump - Install".
- b. Install the timing gears. Refer to Disassembly and Assembly, "Gear Group (Front) - Install".
- c. If the engine has an accessory drive, install the accessory drive. Refer to Disassembly and Assembly, "Accessory Drive - Remove and Install".
- d. Install the engine oil pan. Refer to Disassembly and Assembly, "Engine Oil Pan - Install".
- e. Install the vibration damper and pulley. Refer to Disassembly and Assembly, "Vibration Damper and Pulley - Install".
- f. If necessary, install the alternator. Refer to Disassembly and Assembly, "Alternator - Install".
- g. Install the fan and pulleys. Refer to Disassembly and Assembly, "Fan - Remove and Install".
- h. Fill the cooling system with coolant. Refer to Operation and Maintenance Manual, "Cooling System Coolant - Fill" for the correct procedure.

i04528053

Accessory Drive - Remove and Install (Accessory Drive SAE "A")

Removal Procedure

Table 43

Required Tools			
Tool	Part Number	Part Description	Qty
A	-	Bearing Puller	1
	-	Puller	1
	-	Crossblock	1
	-	Puller Leg	2

NOTICE

Keep all parts clean from contaminants.

Contaminants may cause rapid wear and shortened component life.

NOTICE

Care must be taken to ensure that fluids are contained during performance of inspection, maintenance, testing, adjusting and repair of the product. Be prepared to collect the fluid with suitable containers before opening any compartment or disassembling any component containing fluids.

Dispose of all fluids according to local regulations and mandates.

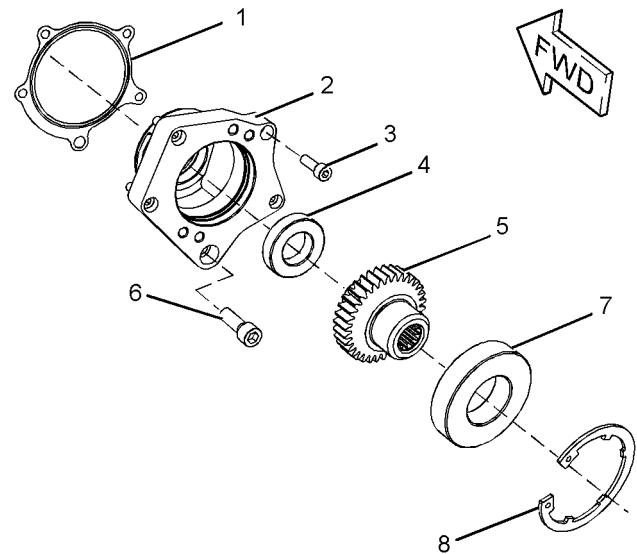

Illustration 148

g02086073

Typical example

1. Remove allen head screw (3) from accessory drive housing (2). Remove allen head screws (6) from accessory drive housing (2).
2. Remove accessory drive housing (2) from the front housing.
3. If necessary, follow Step 3.a through Step 3.d in order to disassemble the accessory drive.
 - a. Remove circlip (8) from accessory drive housing (2).
 - b. Place accessory drive housing (2) onto a suitable support. Press the assembly of gear (5) and bearing (7) and bearing (4) out of accessory drive housing (2).
 - c. Use Tooling (A) in order to remove bearing (7) and bearing (4) from gear (5).
 - d. Remove gasket (1) from accessory drive housing (2).

Installation Procedure

Table 44

Required Tools			
Tool	Part Number	Part Description	Qty
B	-	Loctite 603 Retaining Compound	1-
C	-	Loctite 242 Thread Lock Compound	1

NOTICE

Keep all parts clean from contaminants.

Contaminants may cause rapid wear and shortened component life.

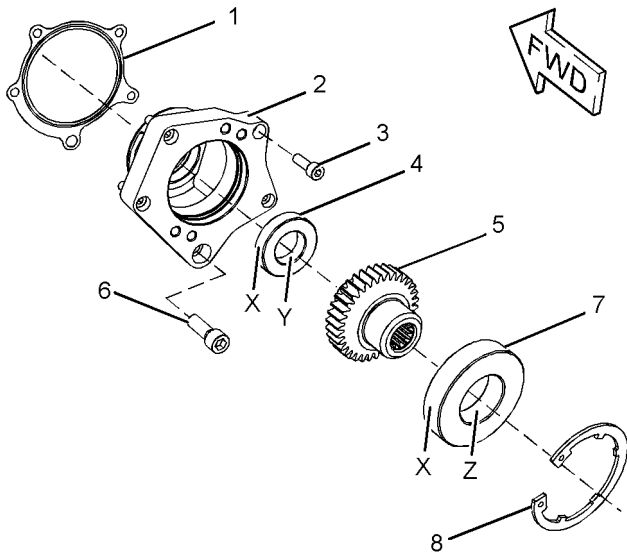

Illustration 149

g02086222

Typical example

1. If necessary, follow Step 1.a through Step 1.e in order to assemble the accessory drive.
 - a. Inspect the condition of the teeth and the splines of gear (5) for wear and damage. Inspect bearing (7), bearing (4), and circlip (8). Inspect the front housing for wear and damage. Replace any components that are worn or damaged.
 - b. Apply a small continuous bead of Tooling (B) to inner Surface (Y) of bearing (4). Place the gear shaft on a suitable support. Press on the inner race of bearing (4) until bearing (4) is against the shoulder of gear (5). Remove any excess compound.

- c. Apply a small continuous bead of Tooling (B) to inner Surface (Z) of bearing (7). Place the inner race of bearing (7) onto a suitable support. Press the shaft of gear (5) into bearing (7) until the shoulder of the gear is against the bearing. Remove any excess compound.

- d. Apply a small continuous bead of Tooling (B) to the outer Surface (X) of bearing (7) and bearing (4). Place accessory drive housing (2) on a suitable support. Press the assembly of the gear into the accessory drive housing. Ensure that bearing (4) is against the front face of the recess in accessory drive housing (2). Remove any excess compound.

- e. Install circlip (8) into the groove in accessory drive housing (2). Ensure that circlip (8) is correctly positioned in the groove.

2. Install gasket (1) to accessory drive housing (2).
3. Inspect the bore in the front housing for damage. If necessary, replace the front housing. Refer to Disassembly and Assembly, "Housing (Front) - Remove" and Disassembly and Assembly, "Housing (Front) - Install" for the correct procedure.
4. Lightly lubricate bearing (7), bearing (4), and gear (5) with clean engine lubricating oil. Install the assembly of the accessory drive to the front housing. Ensure that the flange on the accessory drive housing is flush with the front housing.
5. Install new M8 allen head screws (3) to accessory drive housing (2). Tighten the allen head screws to a torque of 22 N·m (195 lb in).
6. Install a new M12 allen head screw (6) to accessory drive housing (2). Tighten allen head screw (6) to a torque of 78 N·m (58 lb ft).
7. Ensure that there is tactile backlash between the idler gear and the accessory drive gear.

i04472957

Crankcase Breather - Remove (Unfiltered Breather)

Removal Procedure

NOTICE

Keep all parts clean from contaminants.

Contaminants may cause rapid wear and shortened component life.

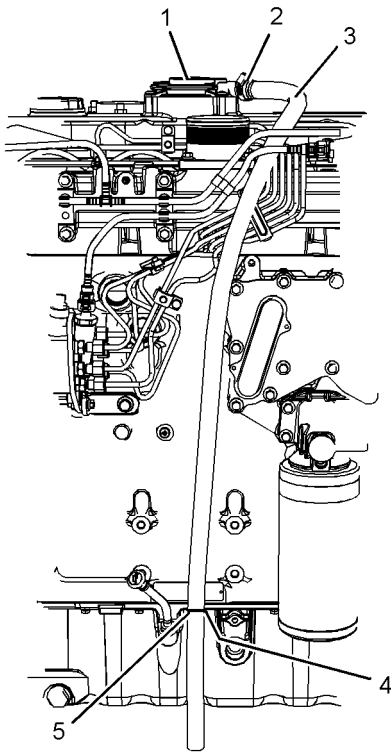

Illustration 150

g02727965

1. Loosen hose clamp (2) and remove plastic tube assembly (3) from breather (1).
2. Remove plastic tube assembly (3) from clip (5).
3. Remove bolt (4) (not shown) from clip (5) and remove the clip.

i04472955

Crankcase Breather - Remove (Filtered Breather)

Removal Procedure

NOTICE

Keep all parts clean from contaminants.

Contaminants may cause rapid wear and shortened component life.

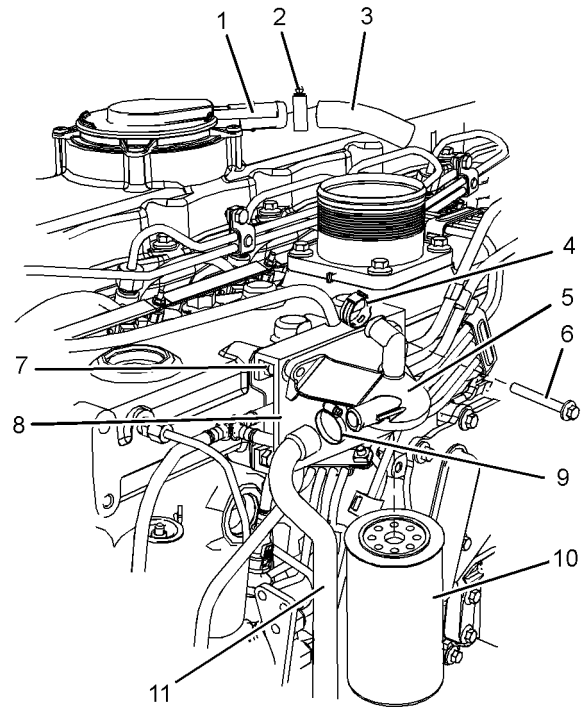

Illustration 151

g02728043

1. Remove canister (10) for the breather. Refer to Operation and Maintenance Manual, "Crankcase Breather (Canister) - Replace".
2. Loosen clamp (2) and clamp (4).
3. Remove hose (3) from valve mechanism cover (1) and filter head (5) for the crankcase breather.
4. Loosen clamp (9) and disconnect hose assembly (11) from filter head (5) for the crankcase breather.
5. Remove bolts (6) and remove filter head (5) for the crankcase breather from mounting bracket (7).
6. If necessary, follow Step 6.a through Step 6.b in order to remove mounting bracket (8) from the cylinder head.
 - a. Remove bolts (7) from mounting bracket (8).
 - b. Remove mounting bracket (8) from the cylinder head.

i04472954

Crankcase Breather - Install (Filtered Breather)

Installation Procedure

NOTICE

Keep all parts clean from contaminants.

Contaminants may cause rapid wear and shortened component life.

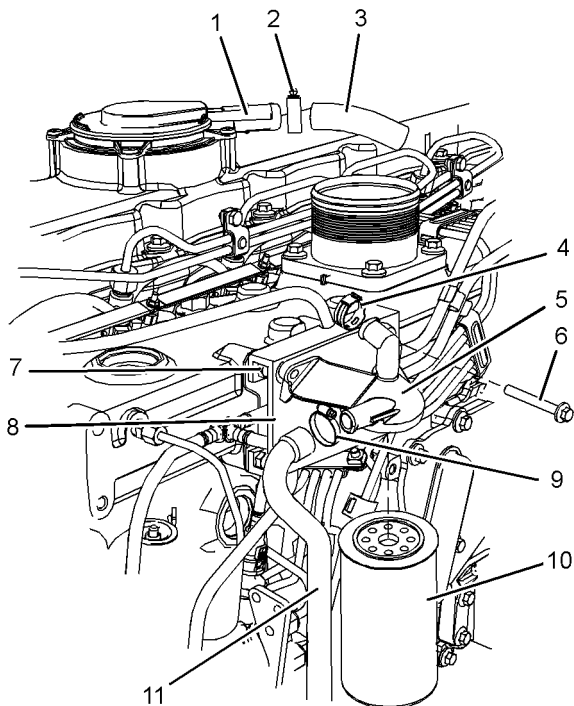

Illustration 152

g02728043

1. If necessary, follow Step 1.a through Step 1.c in order to install mounting bracket (8) to the cylinder head.
 - a. Position mounting bracket (8) onto the cylinder head.
 - b. Install bolts (7) to mounting bracket (8).
 - c. Tighten bolts (17) to a torque of 22 N·m (195 lb in).
2. Position filter head (5) for the crankcase breather onto mounting bracket (7). Install bolts (6).
3. Tighten bolts (6) to a torque of 22 N·m (195 lb in).

4. Connect hose assembly (11) to filter head (5) for the crankcase breather.
5. Tighten clamp (9) securely.
6. Connect hose (3) to valve mechanism cover (1) and filter head (5) for the crankcase breather.
7. Tighten clamp (2) and clamp (4) securely.
8. Install a new canister (10) to filter head (5) for the crankcase breather. Refer to Operation and Maintenance Manual, "Crankcase Breather (Canister) - Replace".

i04472956

Crankcase Breather - Install (Unfiltered Breather)

Installation Procedure

NOTICE

Keep all parts clean from contaminants.

Contaminants may cause rapid wear and shortened component life.

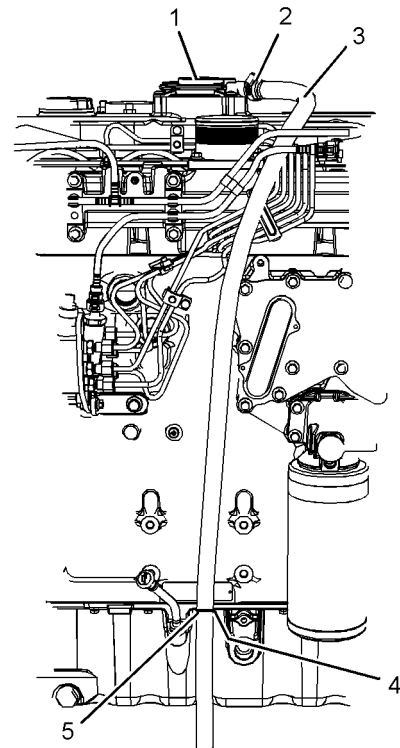

Illustration 153

g02727965

1. Install plastic tube assembly (3) to breather (1). Ensure that the plastic tube assembly is correctly routed.
2. Tighten hose clamp (2) securely.
3. Position clip (5) into correct position. Install bolt (4) (not shown) hand tight.
4. Install plastic tube assembly (3) to clip (5).
5. Tighten bolt (4) (not shown) to a torque of 22 N·m (195 lb in).

i04473094

Valve Mechanism Cover - Remove and Install

Removal Procedure

NOTICE

Keep all parts clean from contaminants.

Contaminants may cause rapid wear and shortened component life.

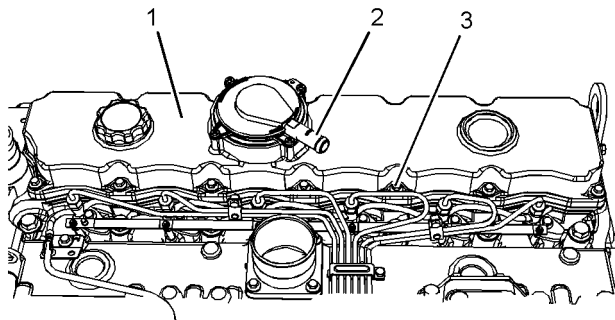

Illustration 154

g02710382

1. Disconnect the plastic tube assembly from connection (2) on valve mechanism cover (1). Refer to Disassembly and Assembly, "Crankcase Breather - Remove" for the correct procedure.
2. Remove bolts (3) from valve mechanism cover (1).
3. Remove valve mechanism cover (1) from the cylinder head.

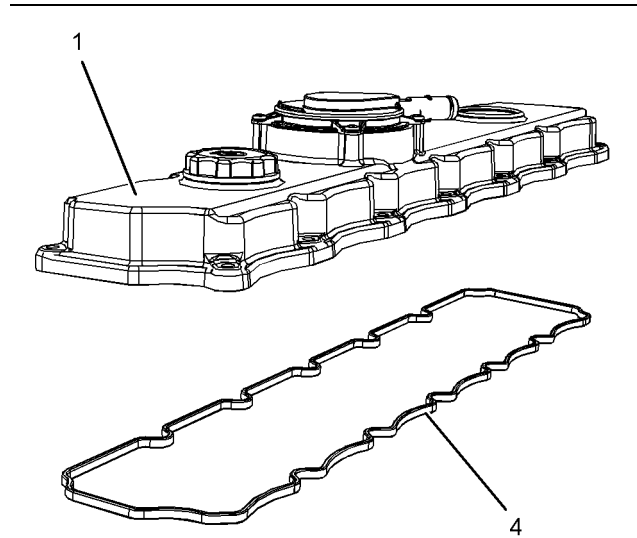

Illustration 155

g02710383

4. Remove seal (4) from valve mechanism cover (1).

Installation Procedure

NOTICE

Keep all parts clean from contaminants.

Contaminants may cause rapid wear and shortened component life.

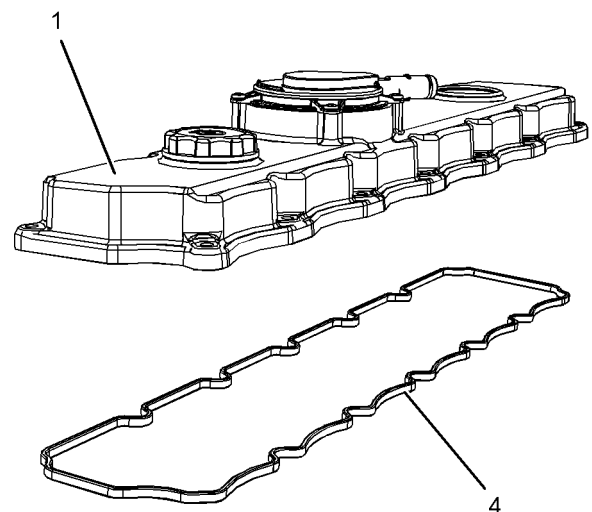

Illustration 156

g02710383

1. Thoroughly clean all gasket surface of valve mechanism cover (1). Clean the gasket surface of the cylinder head.
2. Thoroughly clean the seal recess in the valve mechanism cover (1).

i04473091

3. Inspect seal (4) for damage. If necessary, install a new seal to valve mechanism cover (1).

Note: Ensure that the seal is fully seated into the recess of the valve mechanism cover.

Rocker Shaft and Pushrod - Remove

Removal Procedure

Table 45

Required Tools			
Tool	Part Number	Part Description	Qty
A	-	3/8 inch Drive E10 Torx Socket	1

Start By:

- a. Remove the valve mechanism cover. Refer to Disassembly and Assembly, "Valve Mechanism Cover - Remove and Install".

NOTICE

Keep all parts clean from contaminants.

Contaminants may cause rapid wear and shortened component life.

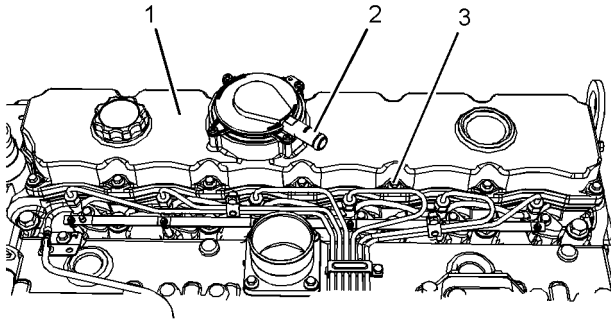

Illustration 157

g02710382

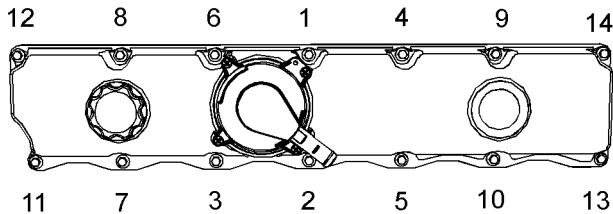

Illustration 158

g02710384

4. Position valve mechanism cover (1) onto the cylinder head.
5. Install bolts (3).
6. Tighten bolts (3) in the numerical sequence that is shown in Illustration 158. Tighten the bolts to a torque of 22 N·m (195 lb in).

Repeat Step 6 in order to ensure correct torque.

7. Connect plastic tube assembly to connection (2) on valve mechanism cover (1). Refer to Disassembly and Assembly, "Crankcase Breather - Remove" for the correct procedure.

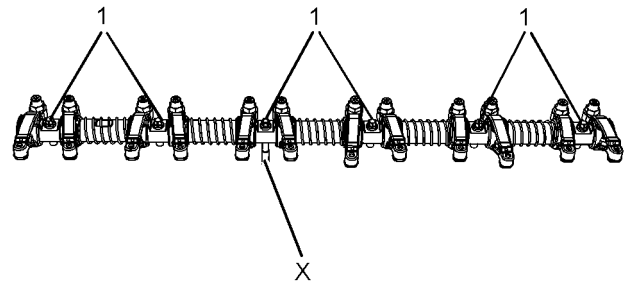

Illustration 159

g02724339

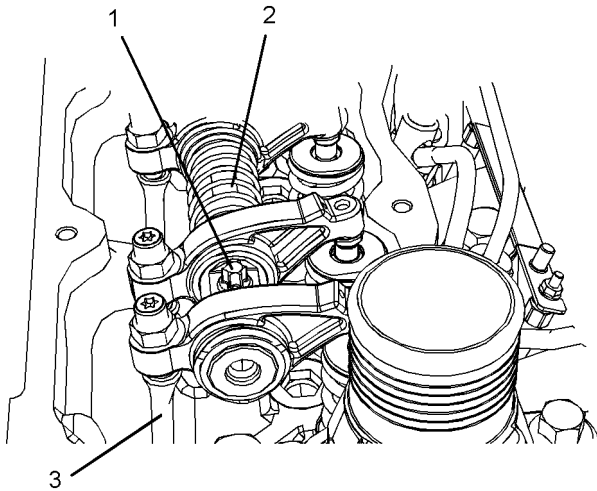

Illustration 160

g02724340

1. Use Tooling (A) in order to progressively loosen torx screws (1). Begin at the ends of the rocker shaft assembly and work toward the center.

Note: To avoid distortion of rocker shaft assembly (2), each torx screw should be loosened by half a turn at one time. Repeat the procedure until all torx screws are loosened.

2. Remove torx screws (1) from rocker shaft assembly (2).

Note: Different length Torx screw in Position (X).

3. Remove rocker shaft assembly (2) from the cylinder head.
4. Place an identification mark on pushrods (3) in order to show the location. Remove the pushrods from the cylinder head.

Note: Identification will ensure that the pushrods can be reinstalled in the original positions. Do not interchange the positions of used pushrods.

i04473070

Rocker Shaft - Disassemble

Disassembly Procedure

Table 46

Required Tools			
Tool	Part Number	Part Description	Qty
A	-	Retaining Ring Pliers	1

Start By:

- a. Remove the rocker shaft assembly. Refer to Disassembly and Assembly, "Rocker Shaft and Pushrod - Remove".

NOTICE

Keep all parts clean from contaminants.

Contaminants may cause rapid wear and shortened component life.

WARNING

Personal injury can result from being struck by parts propelled by a released spring force.

Make sure to wear all necessary protective equipment.

Follow the recommended procedure and use all recommended tooling to release the spring force.

1. Make an identification mark on each rocker arm assembly in order to show the location.

Note: The components must be reinstalled in the original location. Do not interchange components.

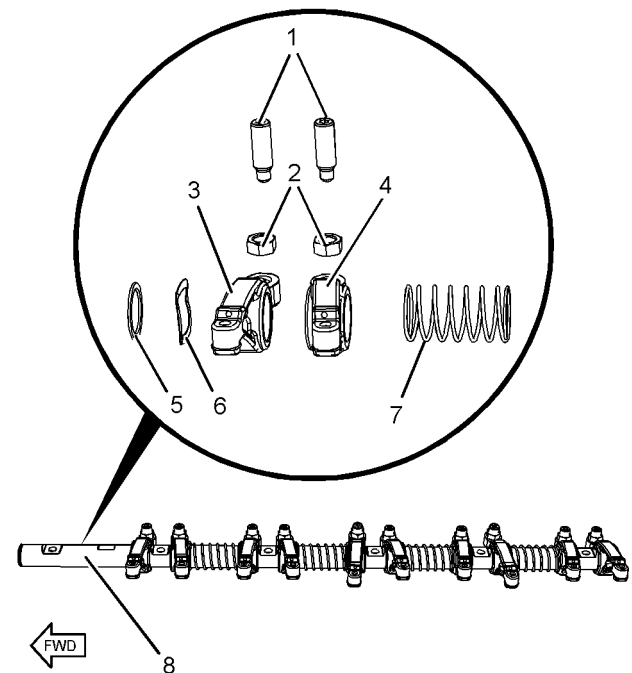

Illustration 161

g02724378

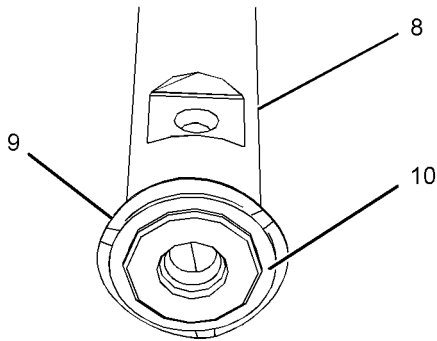

Illustration 162 g02724380

2. If necessary, remove Torx screws from rocker shaft (8).
3. Start disassembly of the rocker shaft at the front.
4. Use Tooling (A) in order to remove retaining clip (5) from rocker shaft (8). Remove wavy washer (6).
5. Remove rocker arm assembly (3) for the inlet valve from rocker shaft (8). Remove rocker arm assembly (4) for the exhaust valve from rocker shaft (8).
6. Remove spring (7) from rocker shaft (8).
7. Repeat Step 5 and Step 6 in order to remove the remaining rocker arms from rocker shaft (8).
8. If necessary, remove retaining clip (10) and remove wavy washer (9) from the rear end of rocker shaft (8).
9. If necessary, remove nuts (2) and adjusters (1) from the rocker arms. Make a temporary identification mark on each adjuster in order to show the location.

Note: The components must be reinstalled in the original location. Do not interchange components.

i04473069

Rocker Shaft - Assemble

Assembly Procedure

Table 47

Required Tools			
Tool	Part Number	Part Description	Qty
A	-	Retaining Ring Pliers	1

NOTICE

Keep all parts clean from contaminants.

Contaminants may cause rapid wear and shortened component life.

1. Ensure that all components are clean and free from wear or damage. Refer to Specifications, "Rocker Shaft" for more information. If necessary, replace any components that are worn or damaged.

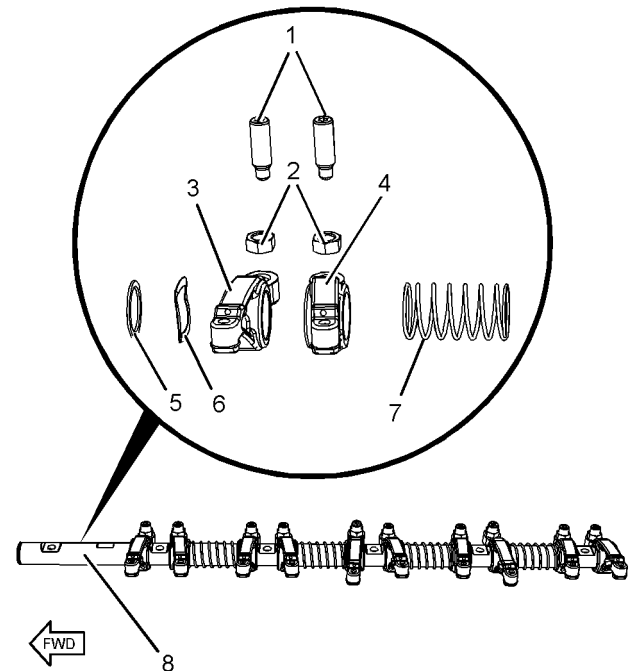

Illustration 163 g02724378

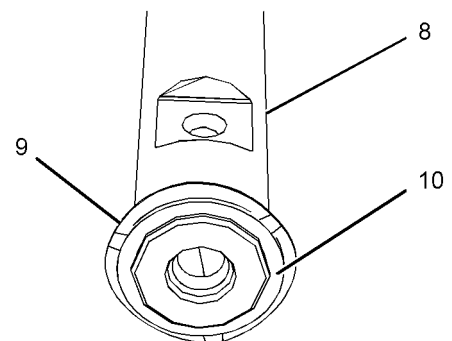

Illustration 164 g02724380

2. If necessary, install nuts (2) and adjusters (1) to rocker arm assembly (3) and rocker arm assembly (4). If the original adjusters are reused, ensure that the adjusters are installed in the original positions.

3. Use Tooling (A) in order to install retaining clip (10) and wavy washer (9) to the rear end of rocker shaft (8).
4. Lubricate the bores of rocker arm assembly (3) and rocker arm assembly (4) and rocker shaft (8) with clean engine oil.
5. Install rocker arm assembly (4) exhaust valve to rocker shaft (8).
6. Install rocker arm assembly (3) inlet valve to rocker shaft (8).

⚠ WARNING

Improper assembly of parts that are spring loaded can cause bodily injury.

To prevent possible injury, follow the established assembly procedure and wear protective equipment.

7. Install spring (7) to rocker shaft (8).
8. Repeat Step 4 through Step 7 in order to assemble the remaining components to rocker shaft (5).
9. After all the rocker arm assemblies have been installed, install wavy washer (6).
10. Use Tooling (A) in order to install retaining clip (5) to the front end of rocker shaft (8).

End By:

- a. Install the rocker shaft assembly. Refer to Disassembly and Assembly, "Rocker Shaft and Pushrod - Install".

i04473090

Rocker Shaft and Pushrod - Install

Installation Procedure

Table 48

Required Tools			
Tool	Part Number	Part Description	Qty
A	-	3/8 inch Drive E10 Torx Socket	1
B	27610227	Rocker Assembly Tool	6

NOTICE

Keep all parts clean from contaminants.

Contaminants may cause rapid wear and shortened component life.

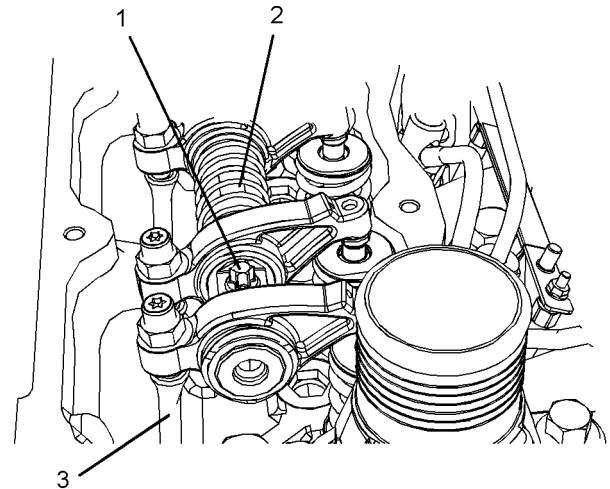

Illustration 165

g02724340

1. Clean the pushrods. Inspect the pushrods for wear or damage. Replace any pushrods that are worn or damaged.
2. Apply clean engine lubricating oil to both ends of pushrods (3). Install the pushrods to the engine with the cup upward.

Note: Ensure that pushrods (3) are installed in the original location and that the ball end of each pushrod is correctly seated in the valve lifters.

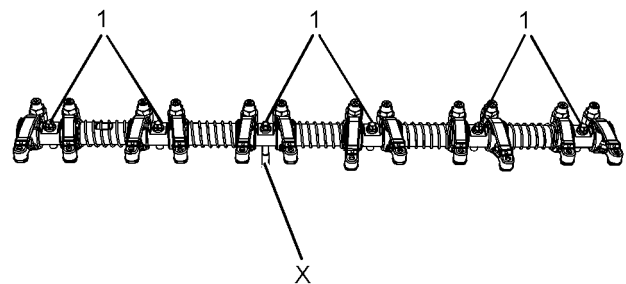

Illustration 166

g02724339

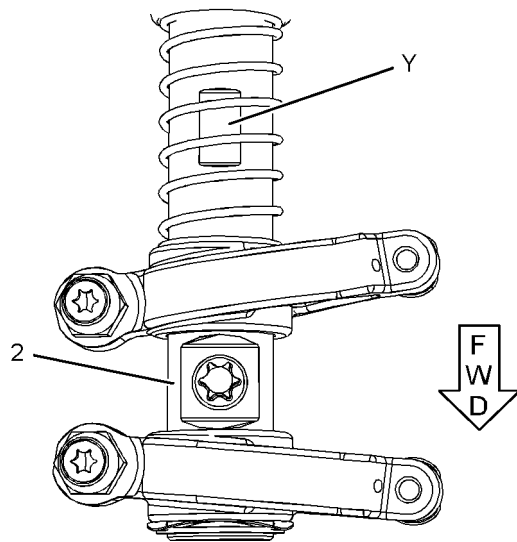

Illustration 167

g02724349

3. Ensure that the rocker shaft assembly is clean and free from wear or damage.
4. Install torx screws (1) into rocker shaft (2). Ensure that the different length Torx screw (1) is installed into Position (X).
5. Install Tooling (B) onto the assembly of rocker shaft (2).
6. Ensure that machined Flat (Y) is facing upward, and machined Flat (Y) is towards the front end of the engine.
7. Position rocker shaft assembly (2) onto the cylinder head.

Note: Ensure that the adjustment screws are correctly seated in ends of pushrods.

8. Use Tooling (A) in order to gradually tighten torx screws (1). Ensure that rocker shaft assembly (2) is correctly positioned onto the cylinder head

Note: To avoid distortion of rocker shaft assembly (2), tighten the torx screws in the center first. Work toward the outside of the rocker shaft assembly.

9. Remove Tooling (B).
10. Tighten torx screws (1) to a torque of 35 N·m (26 lb ft).
11. Check the valve lash. Refer to System Operation, Testing and Adjusting, "Engine Valve Lash - Inspect/Adjust". If necessary, adjust the valve lash. Refer to System Operation, Testing and Adjusting, "Engine Valve Lash - Inspect/Adjust" for the correct procedure.

End By:

- a. Install the valve mechanism cover. Refer to Disassembly and Assembly, "Valve Mechanism Cover - Remove and Install".

i04472966

Cylinder Head - Remove

Removal Procedure

Table 49

Required Tools			
Tool	Part Number	Part Description	Qty
A	T400106	Capping Kit	1

Start By:

- a. Remove the secondary fuel filter and the fuel filter base and bracket. Refer to Disassembly and Assembly, "Fuel Filter Base - Remove and Install" for the correct procedure.
- b. Remove the water separator and fuel filter (Primary) and bracket. Refer to Disassembly and Assembly, "Water Separator and Fuel Filter (Primary) - Remove and Install" for the correct procedure.
- c. Remove the rocker shaft and pushrods. Refer to Disassembly and Assembly, "Rocker Shaft and Pushrods - Remove" for the correct procedure.
- d. Remove the exhaust manifold. Refer to Disassembly and Assembly, "Exhaust Manifold - Remove and Install" for the correct procedure.
- e. Remove the crankcase breather canister and plastic tube assemblies. Refer to Disassembly and Assembly, "Crankcase Breather - Remove" for the correct procedure.
- f. Remove the fuel injectors. Refer to Disassembly and Assembly, "Fuel Injector - Remove" for the correct procedure.
- g. Remove the glow plugs. Refer to Disassembly and Assembly, "Glow Plugs - Remove and Install" for the correct procedure.

NOTICE

Keep all parts clean from contaminants.

Contaminants may cause rapid wear and shortened component life.

NOTICE

Care must be taken to ensure that fluids are contained during performance of inspection, maintenance, testing, adjusting and repair of the product. Be prepared to collect the fluid with suitable containers before opening any compartment or disassembling any component containing fluids.

Dispose of all fluids according to local regulations and mandates.

1. Drain the coolant from the cooling system into a suitable container for storage or for disposal. Refer to Operation and Maintenance Manual, "Cooling System Coolant - Change" for the correct draining procedure.

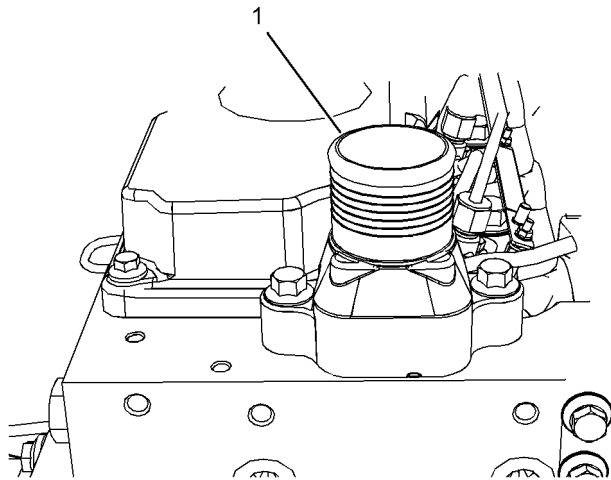

Illustration 168

g02717216

2. Disconnect the upper radiator hose from water temperature regulator housing (1) on the cylinder head.

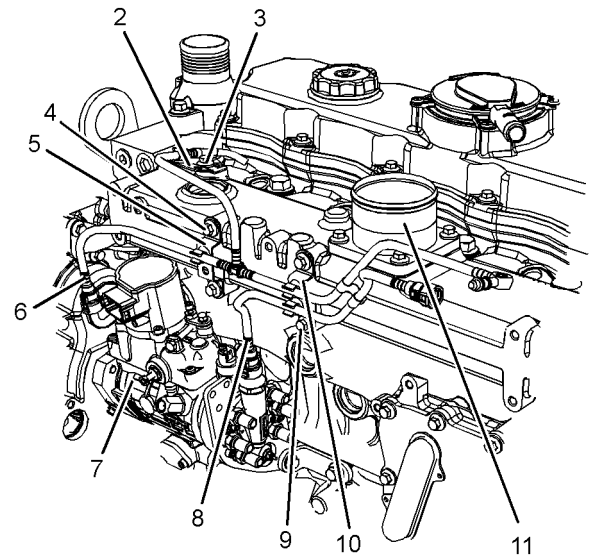

Illustration 169

g02717217

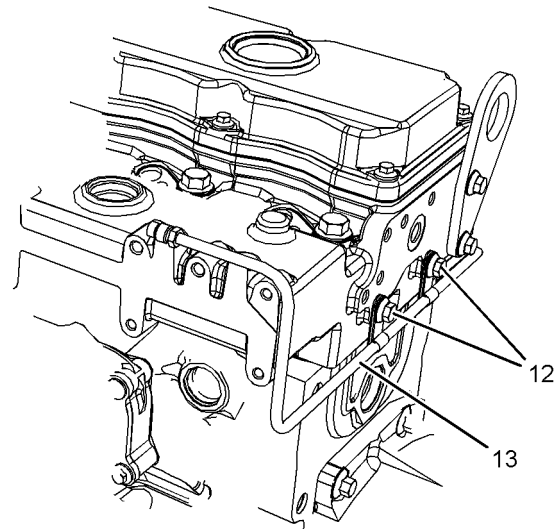

Illustration 170

g02717219

3. Loosen hose the clamp and disconnect the tube assembly and hose assembly from connection (11).
4. Remove bolt (3) and remove bracket (2) from the cylinder head.
5. Remove bolts (4) and bolts (9) from bracket (5) and bracket (10).
6. Disconnect plastic tube assembly (6) and plastic tube assembly (8) from fuel injection pump (7).
7. Use Tooling (A) to plug plastic tube assembly (6) and plastic tube assembly (8).

8. Use Tooling (A) to cap connections on fuel injection pump (7).
9. If necessary, remove the tube assembly from the cylinder head and the boost control on the fuel injection pump. Refer to Disassembly and Assembly, "Fuel Injection Pump- Remove (With Boost Control)" for the correct procedure.
10. Remove bolts (12) from the clips for tube assembly (13).

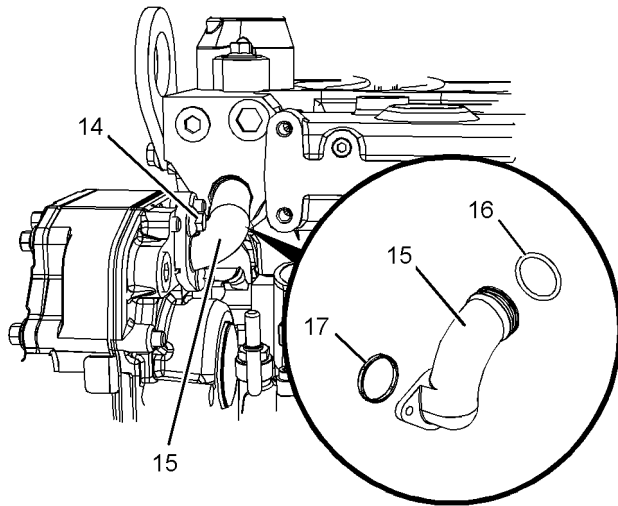

Illustration 171

g02717238

11. Remove bolts (14) from bypass tube (15).
12. Remove bypass tube (15) from the cylinder head.
13. Remove O-ring seal (16) and O-ring seal (17) from bypass tube (15).

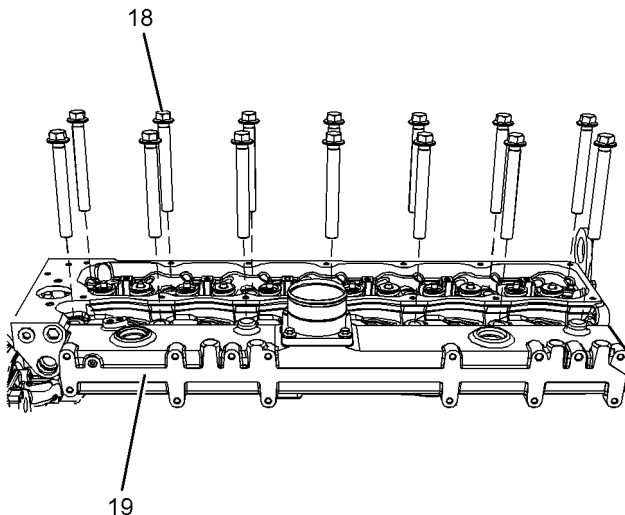

Illustration 172

g02717247

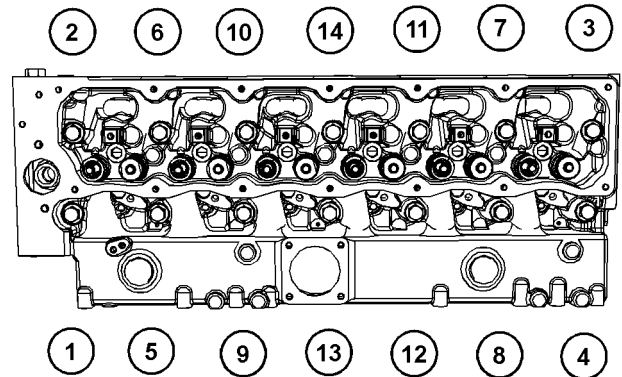

Illustration 173

g02717248

Sequence for tightening the bolts for the cylinder head

14. Gradually loosen bolts (18) in the reverse numerical order to the tightening sequence. Refer to the Illustration 173.

Note: Follow the correct sequence in order to help prevent distortion of the cylinder head.

15. Remove bolts (18) from cylinder head (19).

16. Attach a suitable lifting device to cylinder head (19). Support the weight of the cylinder head. The weight of the cylinder head is approximately 96 kg (212 lb).

Note: A spreader bar must be used in order to distribute the weight of the cylinder head during the lifting operation.

17. Use the suitable lifting device to lift cylinder head (19) off the cylinder block.

Note: Do not use a lever to separate the cylinder head from the cylinder block. Take care not to damage the machined surfaces of the cylinder head during the removal procedure.

NOTICE

Place the cylinder head on a surface that will not scratch the face of the cylinder head.

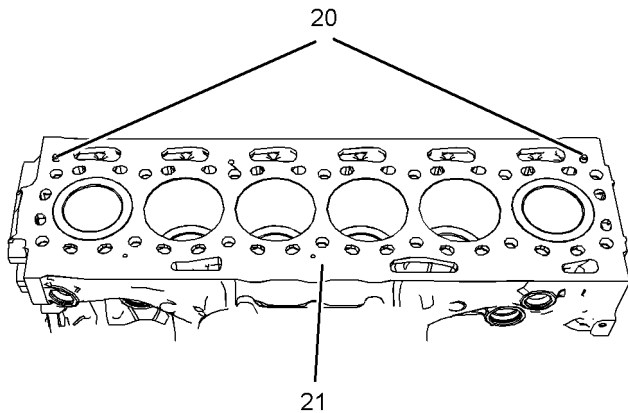

Illustration 174

g02717250

18. Remove cylinder head gasket (21).
19. Note the position of dowels (20) in the cylinder block.
20. If necessary, remove the water temperature regulator from the cylinder head. Refer to Disassembly and Assembly, "Water Temperature Regulator - Remove and Install" for the correct procedure.

i04472965

Cylinder Head - Install

Installation Procedure

Table 50

Required Tools			
Tool	Part Number	Part Description	Qty
B	-	Guide Studs M16 by 115mm	2
C	21825607	Degree Wheel	1
D	-	Delphi Lockheed Rubber Grease	1

NOTICE

Keep all parts clean from contaminants.

Contaminants may cause rapid wear and shortened component life.

1. Thoroughly clean the gasket surfaces of the cylinder head and the cylinder block. Do not damage the gasket surfaces of the cylinder head or the cylinder block. Ensure that no debris enters the cylinder bores, the coolant passages, or the lubricant passages.
2. Inspect the gasket surface of the cylinder head for distortion. Refer to Specifications, "Cylinder Head" for more information. If the gasket surface of the cylinder head is distorted beyond maximum permitted limits, replace the cylinder head.

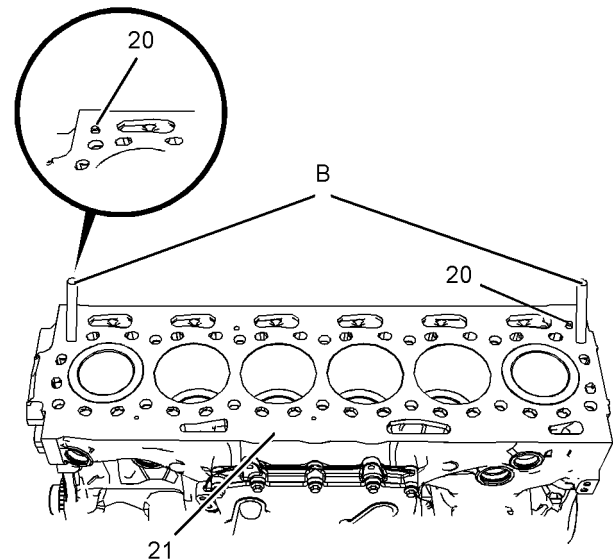

Illustration 175

g02717296

3. Inspect dowels (20) for damage. If necessary, replace the dowels in the cylinder block.
4. Install Tooling (B) to the cylinder block.
5. Align a new cylinder head gasket (21) with dowels (19). Install the new cylinder head gasket (20) onto the cylinder block.
6. Use a suitable lifting device to lift cylinder head. The weight of the cylinder head is approximately 96 kg (212 lb).

Note: A spreader bar must be used in order to distribute the weight of the cylinder head during the lifting operation.
7. Use Tooling (B) to align the cylinder head with the cylinder block. Install the cylinder head to the cylinder block.

Note: Ensure that the cylinder head is correctly positioned on dowels (20).
8. Remove Tooling (B).

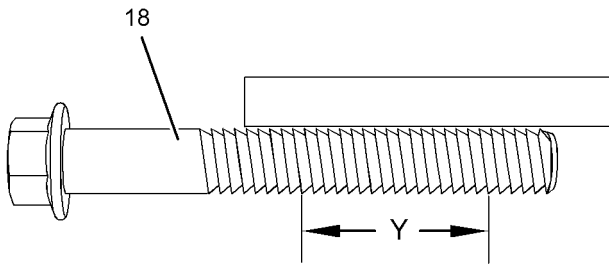

Illustration 176

g02717298

9. Clean bolts (18). Follow Step 9.a for the procedure to inspect the bolts.
 - a. Use a straight edge to check the threads of the bolts. Refer to Illustration 176. Replace any bolts that show visual reduction in the diameter of the thread over Length (Y).
10. Lubricate the threads and the shoulder of bolts (18) with clean engine oil.

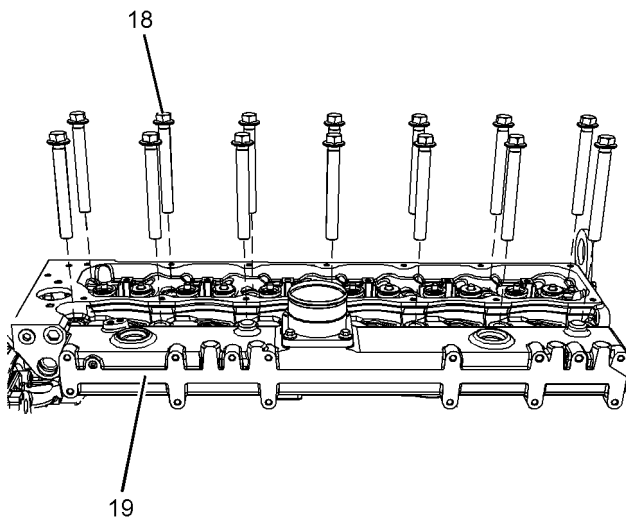

Illustration 177

g02717339

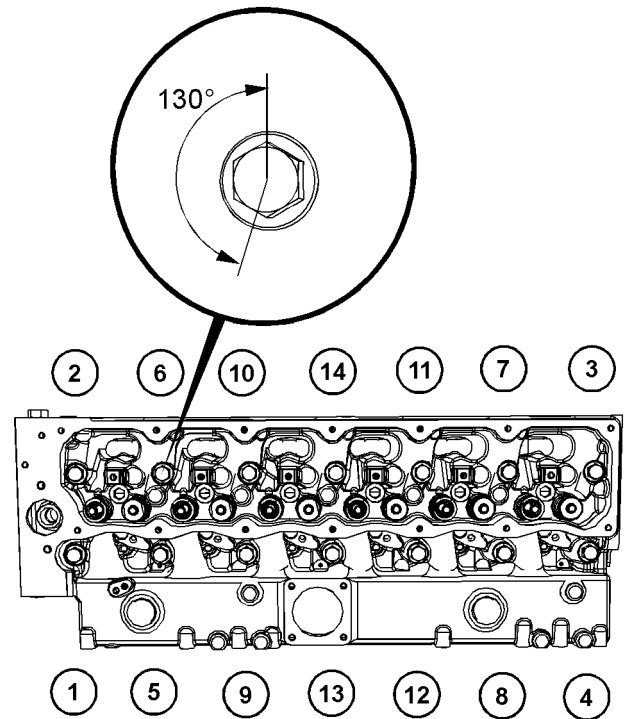

Illustration 178

g02717340

11. Install bolts (18) to cylinder head (19).
12. Tighten the bolts to a torque of 50 N·m (37 lb ft) in the numerical sequence that is shown in Illustration 178.
13. Tighten the bolts to a torque of 160 N·m (118 lb ft) in the numerical sequence that is shown in Illustration 178.
14. Use Tooling (C) in order to turn the bolts through an additional 130 degrees in the numerical sequence that is shown in Illustration 178.

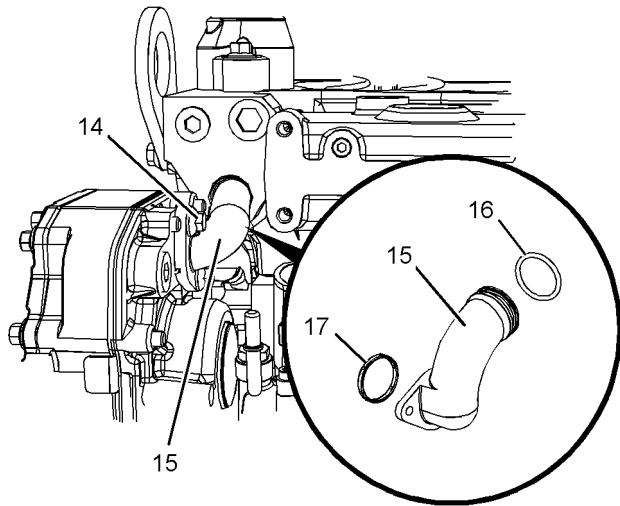

Illustration 179

g02717238

- 15.** Use Tooling (D) in order to lubricate new O-ring seal (16) and O-ring seal (17). Install O-ring seal (16) and O-ring seal (17) to bypass tube (15).
- 16.** Install the bypass tube in the cylinder head. Install bolts (14). Tighten the bolts to a torque of 22 N·m (195 lb in).

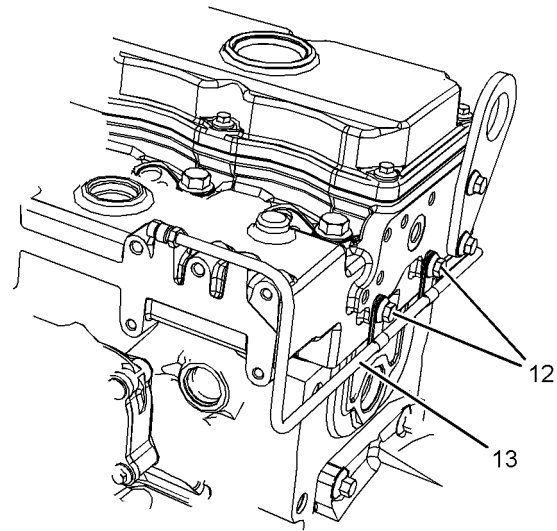

Illustration 181

g02717219

- 17.** Install bolts (12) to the clips for tube assembly (13). Tighten the bolts to a torque of 44 N·m (32 lb ft).
- 18.** Remove plugs from plastic tube assembly (6) and plastic tube assembly (8).
- 19.** Remove caps from connections on fuel injection pump (7)
- 20.** Connect plastic tube assembly (6) and plastic tube assembly (8) to fuel injection pump (7).
- 21.** Position bracket (5) and bracket (10) onto cylinder head.
- 22.** Install bolts (4) and bolts (9) to bracket (5) and bracket (10). Tighten the bolts to a torque of 22 N·m (195 lb in).
- 23.** Position bracket (2) onto the cylinder head. Install bolt (3) to the bracket. Tighten the bolt to a torque of 22 N·m (195 lb in).
- 24.** Connect the tube assembly and hose assembly from connection (11). Tighten hose the clamp securely.
- 25.** If necessary, install the tube assembly from the cylinder head and the boost control on the fuel injection pump. Refer to Disassembly and Assembly, "Fuel Injection Pump- Install (With Boost Control)" for the correct procedure.

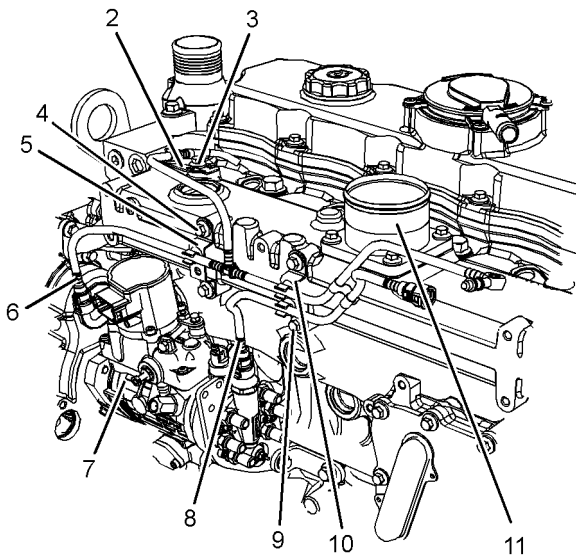

Illustration 180

g02717217

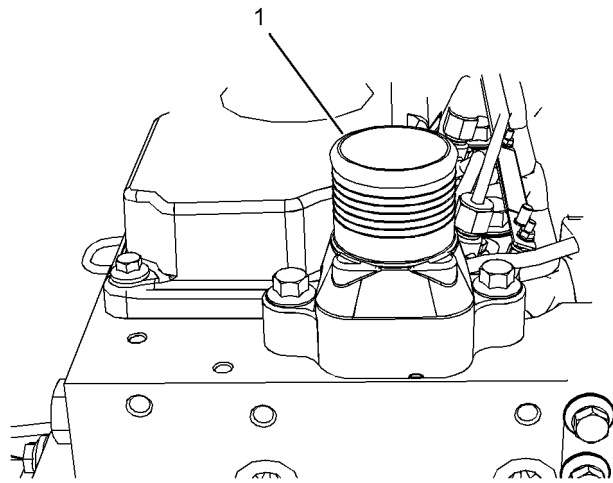

Illustration 182

g02717216

26. If necessary, install water temperature regulator housing (1) to the cylinder head. Refer to Disassembly and Assembly, "Water Temperature Regulator Housing - Remove and Install" for the correct procedure.

27. Connect the upper radiator hose to water temperature regulator housing (1) on the cylinder head. Tighten hose clamp securely.

End By:

- a. Install the rocker shaft and pushrods. Refer to Disassembly and Assembly, "Rocker Shaft and Pushrods - Install" for the correct procedure.
- b. Install the fuel injectors. Refer to Disassembly and Assembly, "Fuel Injector - Install" for the correct procedure.
- c. Install the glow plugs. Refer to Disassembly and Assembly, "Glow Plugs - Remove and Install" for the correct procedure.
- d. Install the secondary fuel filter and the fuel filter base and bracket. Refer to Disassembly and Assembly, "Fuel Filter Base - Remove and Install" for the correct procedure.
- e. Install the water separator and fuel filter (Primary) and bracket. Refer to Disassembly and Assembly, "Water Separator and Fuel Filter (Primary) - Remove and Install" for the correct procedure.
- f. Install the exhaust manifold. Refer to Disassembly and Assembly, "Exhaust Manifold - Remove and Install" for the correct procedure.

- g. Install the crankcase breather canister and plastic tube assemblies. Refer to Disassembly and Assembly, "Crankcase Breather - Install" for the correct procedure.
- h. Fill the cooling system with coolant. Refer to Operation and Maintenance Manual, "Cooling System Coolant - Change" for the correct filling procedure.
- i. If necessary, fill the engine oil pan to the correct level that is indicated on the engine oil level gauge. Refer to Operation and Maintenance Manual, "Engine Oil Level - Check" for the correct procedure.

i04473062

Lifter Group - Remove and Install

Removal Procedure

Table 51

Required Tools			
Tool	Part Number	Part Description	Qty
A	T400011	Crankshaft Turning Tool	1
B	-	Telescopic Magnet	1

Start By:

- a. Remove the camshaft. Refer to Disassembly and Assembly, "Camshaft - Remove and Install".

NOTICE

Keep all parts clean from contaminants.

Contaminants may cause rapid wear and shortened component life.

1. If the crankshaft is installed, use Tooling (A) to rotate the crankshaft in order to gain access to lifters (1).

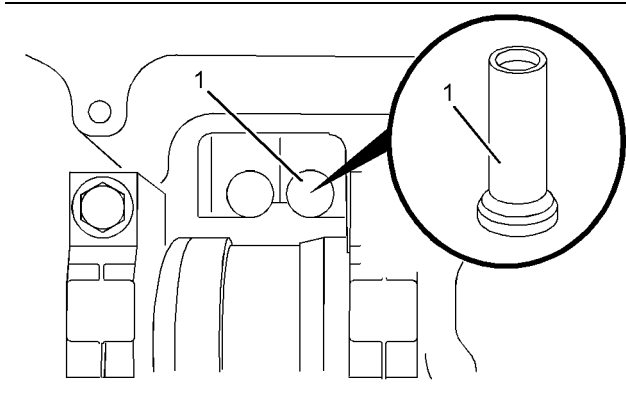

Illustration 183

g01340518

Typical example

2. Use Tooling (B) in order to remove lifters (1).

Note: Make a temporary identification mark on each lifter in order to identify the correct location.

3. Repeat Step 1 and Step 2 in order to remove the remaining lifters.

Installation Procedure

Table 52

Required Tools			
Tool	Part Number	Part Description	Qty
A	T400011	Crankshaft Turning Tool	1
B	-	Telescopic Magnet	1

NOTICE

Keep all parts clean from contaminants.

Contaminants may cause rapid wear and shortened component life.

NOTICE

It is strongly recommended that all lifters should be replaced when a new camshaft is installed.

1. Check all the components for wear and damage. Replace any components that are worn or damaged.
2. Clean the lifters. Follow Step 2.a through Step 2.c in order to inspect the lifters. Replace lifters that are worn or damaged.
 - a. Inspect the seat of the pushrod in the lifter for visual wear or damage.
 - b. Inspect the shank of the lifter for wear or damage. Refer to Specifications, "Lifter Group" for more information.

- c. Inspect the face of the lifter that runs on the camshaft for visual wear or damage.

3. If the crankshaft is installed, use Tooling (A) to rotate the crankshaft. Rotate the crankshaft to access to the cylinder block in order to install lifters (1).

4. Lubricate lifters (1) with clean engine oil.

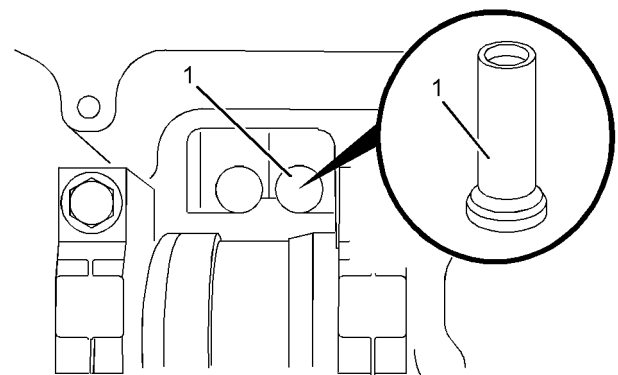

Illustration 184

g01340518

Typical example

5. Use Tooling (B) to install lifters (1) to the cylinder block. Ensure that used lifters are installed in the original location.

Note: The lifters should be free to rotate.

6. Repeat Step 2 through Step 5 in order to install the remaining lifters.

End By:

- a. Install the camshaft. Refer to Disassembly and Assembly, "Camshaft - Remove and Install".

i04472949

Camshaft - Remove and Install

Removal Procedure

Start By:

- a. Remove the fuel priming pump. Refer to Disassembly and Assembly, "Fuel Priming Pump (Mechanical) - Remove and Install" for the correct procedure.
- b. Remove the rocker shaft and pushrods. Refer to Disassembly and Assembly, "Rocker shaft and Pushrod - Remove" for the correct procedure.

- c. Remove the front housing. Refer to Disassembly and Assembly, "Housing (Front) - Remove" for the correct procedure.

NOTICE

Keep all parts clean from contaminants.

Contaminants may cause rapid wear and shortened component life.

1. The engine should be mounted on a suitable stand and placed in the inverted position.
-

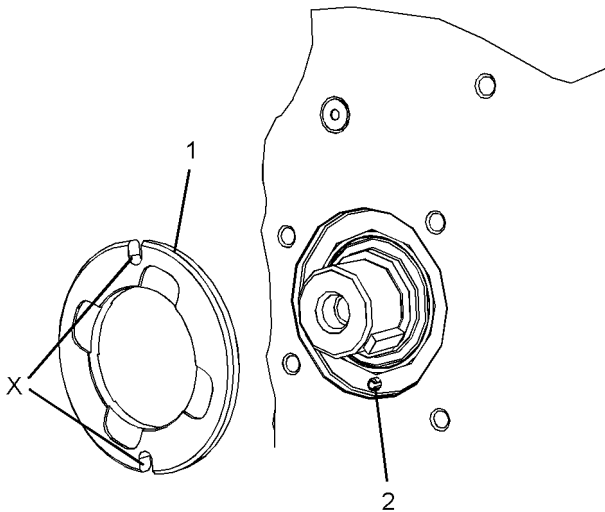

Illustration 185

g02009034

2. Remove thrust washer (1) from the cylinder block. Do not remove dowel (2) from the cylinder block unless the dowel is damaged.

Note: The thrust washer can have one or two Slots (X).

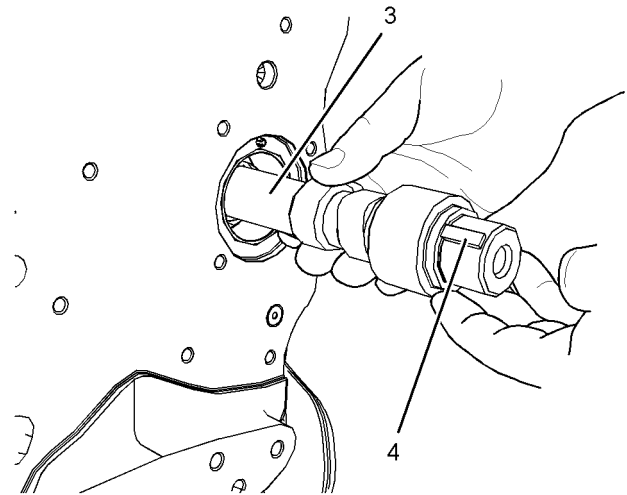

Illustration 186

g02711850

NOTICE

Do not damage the lobes or the bearings when the camshaft is removed or installed.

3. Carefully remove camshaft (3) from the cylinder block.
4. If necessary, remove key (4) from camshaft (3).

Installation Procedure

NOTICE

Keep all parts clean from contaminants.

Contaminants may cause rapid wear and shortened component life.

1. Clean the camshaft and the thrust washer. Inspect the camshaft and the thrust washer for wear and for damage. Refer to Specifications, "Camshaft" for more information. Replace any worn components or any damaged components.
2. Clean the camshaft bearing in the cylinder block. Inspect the camshaft bearing for wear and for damage. Refer to Specifications, "Camshaft Bearings" for more information. If necessary, replace the camshaft bearing. Refer to Disassembly and Assembly, "Camshaft Bearing - Remove and Install" for the correct procedure.

NOTICE

It is strongly recommended that all lifters should be replaced when a new camshaft is installed.

3. Inspect the lifters for wear and for damage. Refer to Specifications, "Lifter Group" for more information. Replace any worn lifters or any damaged lifters. Refer to Disassembly and Assembly, "Lifter Group - Remove and install" for the correct procedure.

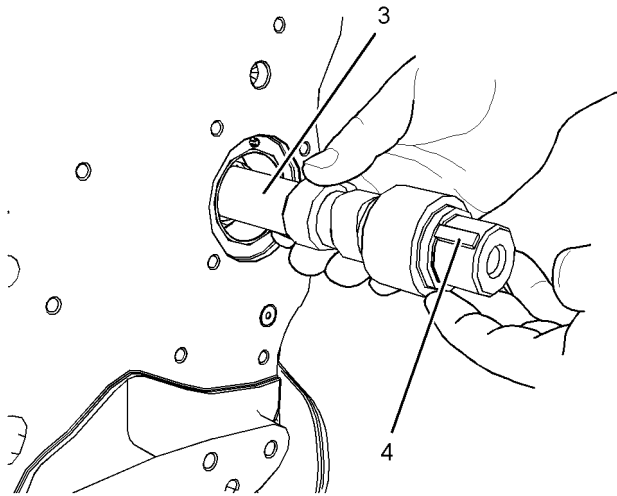

Illustration 187

g02711850

4. If necessary, install a new key (4) into camshaft (3).
5. Lubricate the bearing surfaces of camshaft (3) and lubricate the lobes of the camshaft with clean engine oil.

NOTICE

Do not damage the lobes or the bearings when the camshaft is removed or installed.

6. Carefully install camshaft (3) into the cylinder block.

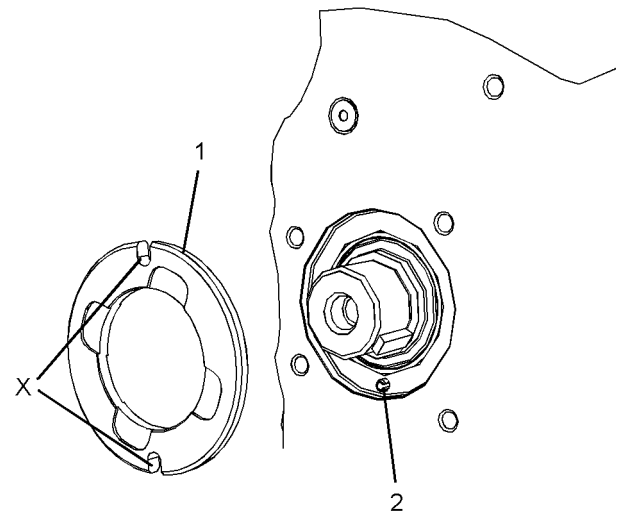

Illustration 188

g02009034

7. Lubricate the thrust washer with clean engine oil. Align Slot (X) in thrust washer (1) with dowel (2) in the cylinder block. Install thrust washer (1) into the recess in the cylinder block.

Note: The thrust washer can have one or two Slots (X).

End By:

- a. Install the front housing. Refer to Disassembly and Assembly, "Housing (Front) - Install" for the correct procedure.
- b. Install the rocker shaft and pushrods. Refer to Disassembly and Assembly, "Rocker shaft and Pushrod - Install" for the correct procedure.
- c. Install the fuel priming pump. Refer to Disassembly and Assembly, "Fuel Priming Pump (Mechanical) - Remove and Install" for the correct procedure.

i04472951

Camshaft Gear - Remove and Install

Removal Procedure

Table 53

Required Tools			
Tool	Part Number	Part Description	Qty
A ⁽¹⁾	T400011	Crankshaft Turning Tool	1
A ⁽²⁾	27610291	Housing	1
	27610289	Engine Turning Tool	1
B	27610212	Timing Pin (Camshaft)	1
C	27610286	Timing Pin (Crankshaft)	1

(1) The Crankshaft Turning Tool is used on the front pulley.

(2) This Tool is used in the aperture for the electric starting motor.

Start By:

- a. Remove the valve mechanism cover. Refer to Disassembly and Assembly, "Valve Mechanism Cover - Remove and Install".
- b. Remove the front cover. Refer to Disassembly and Assembly, "Front Cover - Remove and Install".

Note: Either Tooling (A) can be used. Use the Tooling that is most suitable.

NOTICE

Keep all parts clean from contaminants.

Contaminants may cause rapid wear and shortened component life.

NOTICE

Care must be taken to ensure that fluids are contained during performance of inspection, maintenance, testing, adjusting and repair of the product. Be prepared to collect the fluid with suitable containers before opening any compartment or disassembling any component containing fluids.

Dispose of all fluids according to local regulations and mandates.

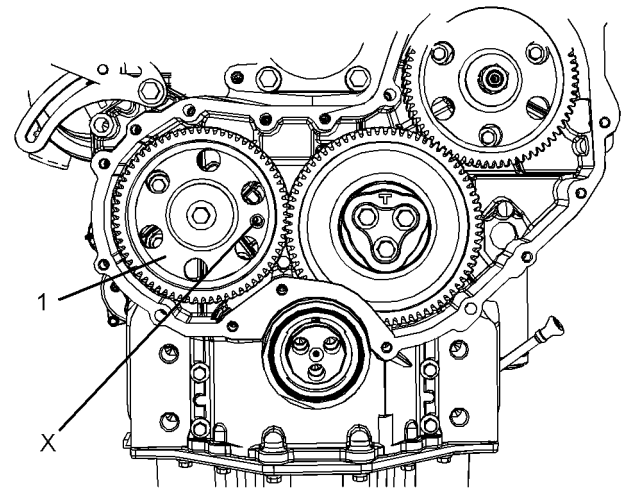

Illustration 189

g02711852

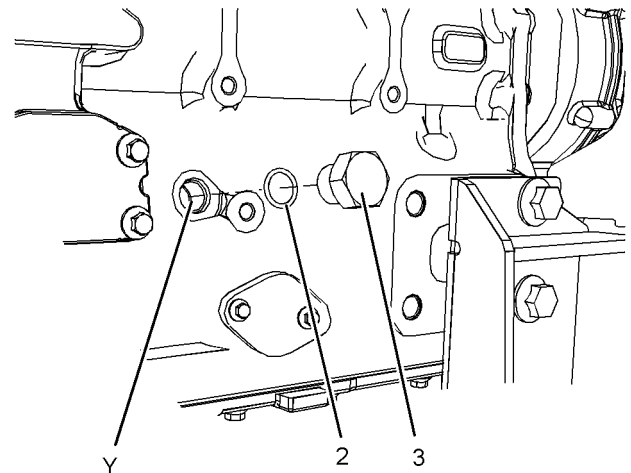

Illustration 190

g02711851

1. Remove plug (3) from the cylinder block. Remove O-ring seal (2) from plug (3).
2. Use Tooling (A) in order to rotate the crankshaft so that number one piston is at top dead center on the compression stroke. Refer to System Operation, Testing and Adjusting, "Finding Top Center Position for No.1 Piston".
3. Install Tooling (C) into Hole (Y) in the cylinder block. Use Tooling (C) in order to lock the crankshaft in the correct position.

Note: Do not use excessive force to install Tooling (C). Do not use Tooling (C) to hold the crankshaft during repairs.

4. Install Tooling (B) through Hole (X) in camshaft gear (1) into the front housing. Use Tooling (B) in order to lock the camshaft in the correct position.

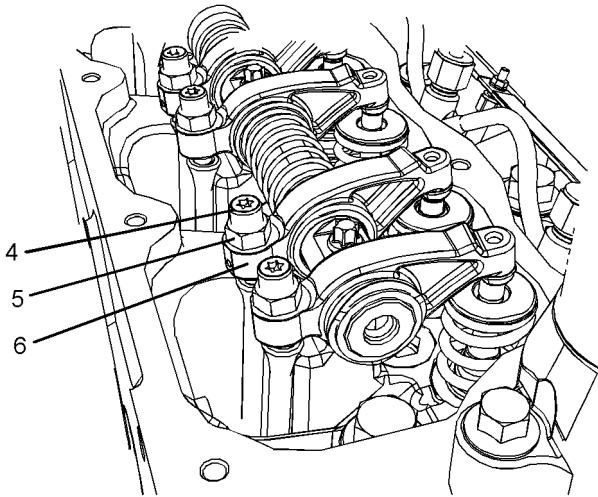

Illustration 191

g02711853

5. Loosen nuts (5) on all rocker arms (6). Unscrew adjusters (4) on all rocker arms (6) until all valves are fully closed.

Note: Failure to ensure that all adjusters are fully unscrewed can result in contact between the valves and pistons.

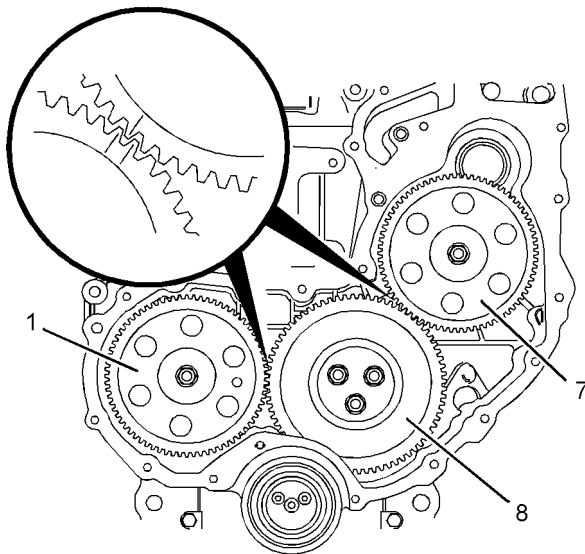

Illustration 192

g02711854

Alignment of timing marks

6. Mark gear (1), gear (7), and gear (8) in order to show alignment. Refer to Illustration 192.

Note: Identification will ensure that the gears can be installed in the original alignment.

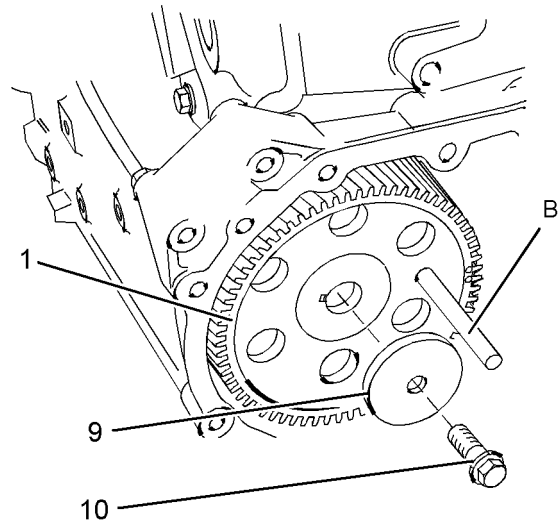

Illustration 193

g02711855

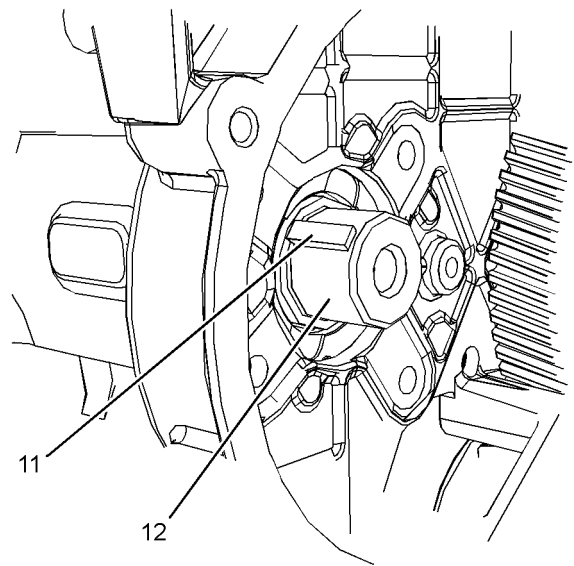

Illustration 194

g02711881

7. Remove Tooling (B) and Tooling (C).
8. Remove bolt (10) and washer (9) from camshaft gear (1).
9. Remove camshaft gear (1) from the camshaft.

Note: If the camshaft gear is a tight fit on the nose of the camshaft, use a prybar in order to remove the camshaft gear.

10. If necessary, remove key (11) from nose of camshaft (12).

Installation Procedure

Table 54

Required Tools			
Tool	Part Number	Part Description	Qty
A ⁽¹⁾	T400011	Crankshaft Turning Tool	1
A ⁽²⁾	27610291	Housing	1
	27610289	Engine Turning Tool	1
C	27610286	Timing Pin (Crankshaft)	1
B	27610212	Timing Pin (Camshaft)	1
D	21825496	Indicator Bracket	1
	21825617	Dial Indicator	1
	-	Indicator Contact Point	1
	-	Universal Attachment	1

(1) The Crankshaft Turning Tool is used on the front pulley.

(2) This Tool is used in the aperture for the electric starting motor.

NOTICE

Keep all parts clean from contaminants.

Contaminants may cause rapid wear and shortened component life.

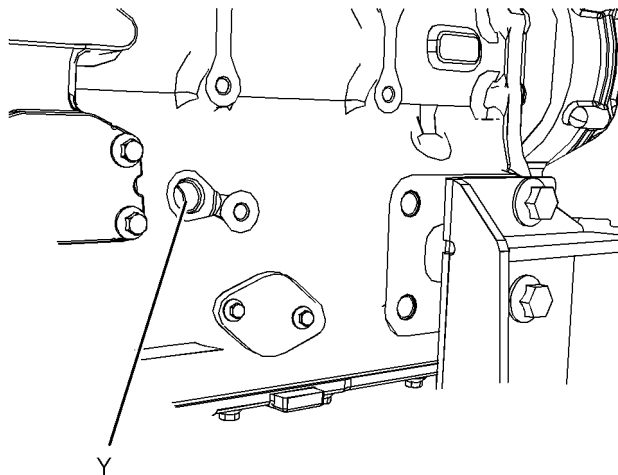

Illustration 195

g02706999

1. If necessary, use Tooling (A) to ensure that number one piston is at top dead center on the compression stroke. Refer to System Operation, Testing and Adjusting, "Finding Top Center Position for No.1 Piston".
2. Ensure that Tooling (C) is installed in Hole (Y) in the cylinder block. Use Tooling (C) in order to lock the crankshaft in the correct position.

Note: Do not use excessive force to install Tooling (C). Do not use Tooling (C) to hold the crankshaft during repairs.

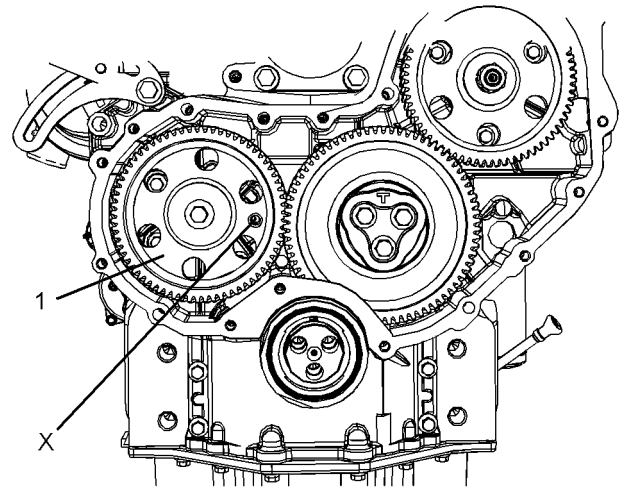

Illustration 196

g02711852

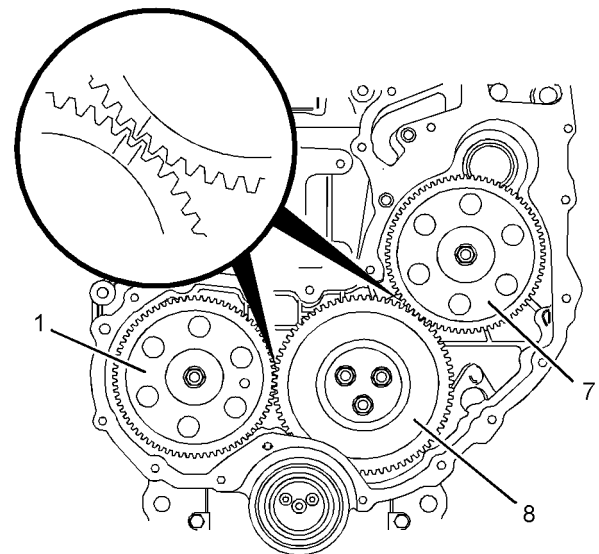

Illustration 197

Alignment of timing marks

g02711854

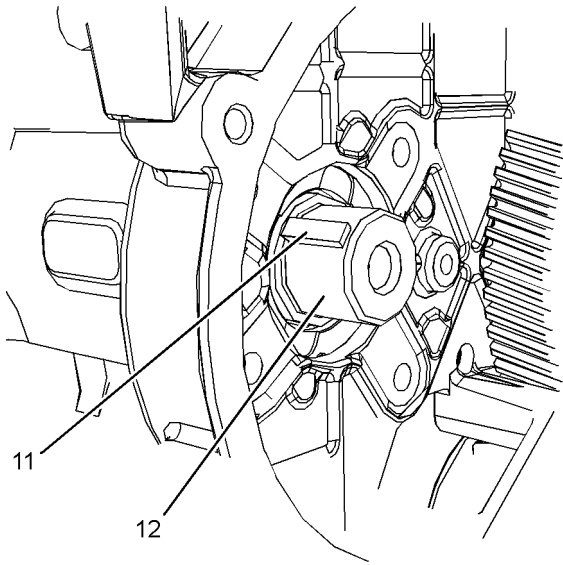

Illustration 198

g02711881

3. Ensure that camshaft gear (1) and key (11) are clean and free from wear or damage.

4. If necessary, install key (11) into the nose of camshaft (12).

Note: Ensure that the key is squarely seated.

5. Align the keyway in camshaft gear (1) with the key in the camshaft. Install camshaft gear onto the camshaft. Ensure that the timing marks on gear (1), gear (7) and gear (8) are in alignment and that the mesh of the gears is correct. Refer to Illustration 197.

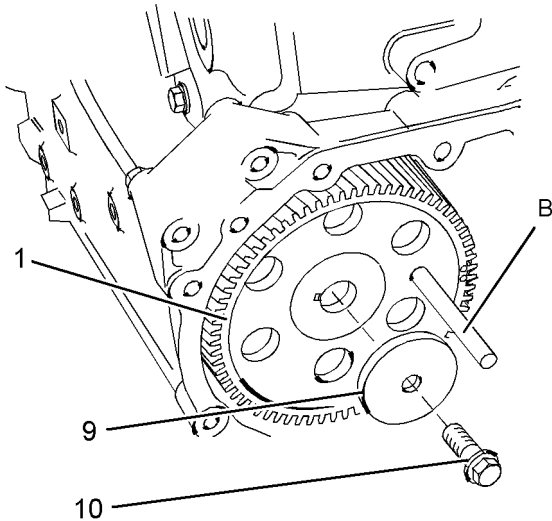

Illustration 199

g02711855

6. Install Tooling (B) through the hole in camshaft gear (1) into the front housing. Install washer (9) and bolt (10) to camshaft gear (1).

7. Remove Tooling (B) and Tooling (C).

8. When bolt (10) is a 8.8 Grade. Tighten bolt (10) to a torque of 95 N·m (70 lb ft).

When bolt (10) is a 10.9 Grade. Tighten bolt (10) to a torque of 120 N·m (89 lb ft).

9. Use Tooling (D) in order to check the backlash for gear (1), gear (7), and gear (8) are within specified values. Refer to Specifications, "Gear Group (Front)" for further information.

10. Use Tooling (D) in order to check the end play for camshaft gear (1) is within specified values. Refer to Specifications, "Camshaft" for further information.

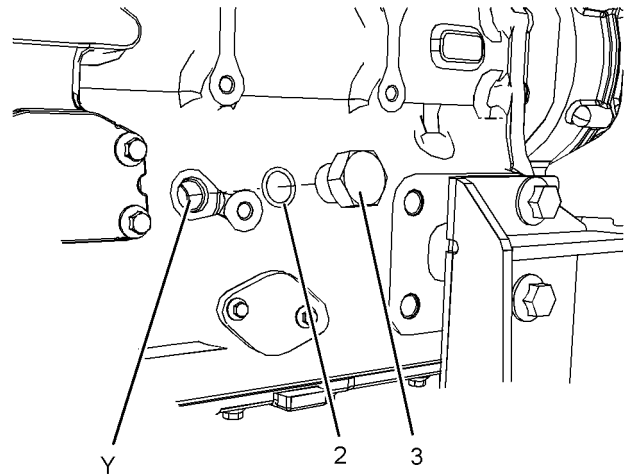

Illustration 200

g02711851

11. Install a new O-ring seal (2) to plug (3). Install plug (3) to the cylinder block. Tighten locking bolt (5) against the spacer to a torque of 21 N·m (186 lb in).

12. Lubricate the teeth of the gears with clean engine oil.

13. Adjust the valve lash. Refer to System Operation, Testing and Adjusting, "Engine Valve Lash - Inspect/Adjust".

End By:

a. Install the front cover. Refer to Disassembly and Assembly, "Front Cover - Remove and Install".

- b. Install the valve mechanism cover. Refer to Disassembly and Assembly, "Valve Mechanism Cover - Remove and Install".

i04472950

Camshaft Bearings - Remove and Install

Removal Procedure

Table 55

Required Tools			
Tool	Part Number	Part Description	Qty
A	-	Bearing Puller	1

Start By:

- a. Remove the engine oil pump. Refer to Disassembly and Assembly, "Engine Oil Pump - Remove".
- b. Remove the camshaft. Refer to Disassembly and Assembly, "Camshaft - Remove and Install".

NOTICE

Keep all parts clean from contaminants.

Contaminants may cause rapid wear and shortened component life.

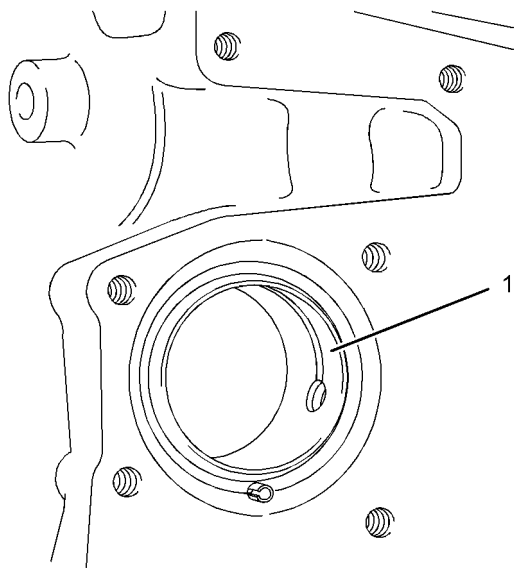

Illustration 201

g01340581

- 1. Inspect camshaft bearing (1). Refer to Specifications, "Camshaft Bearings" for more information.

- 2. If camshaft bearing (1) is worn or damaged, use Tooling (A) in order to remove the camshaft bearing from the cylinder block.

Note: Remove the camshaft bearing from the front of the cylinder block.

Installation Procedure

Table 56

Required Tools			
Tool	Part Number	Part Description	Qty
A	-	Bearing Puller	1

NOTICE

Keep all parts clean from contaminants.

Contaminants may cause rapid wear and shortened component life.

- 1. Clean the bearing housing in the cylinder block. Ensure that the oil hole in the bearing housing is free from debris.

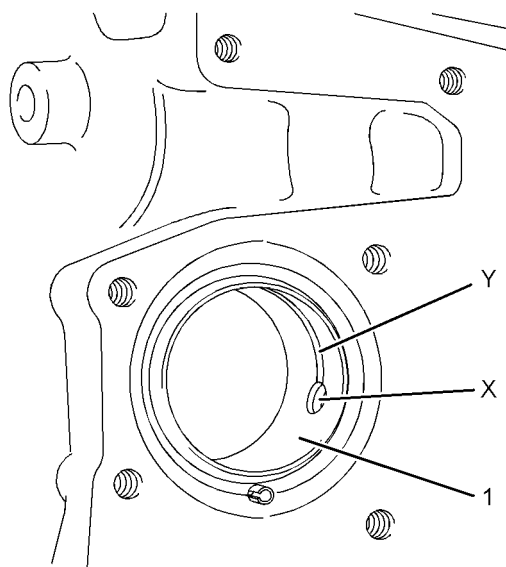

Illustration 202

g01340583

- 2. Lubricate the bearing housing in the cylinder block with clean engine oil.
- 3. Accurately align large oil Hole (X) in camshaft bearing (1) with the oil hole in the cylinder block.

Note: The Groove (Y) in the camshaft bearing must be to the top of the cylinder block.

- 4. Use Tooling (A) in order to install camshaft bearing (1) into the cylinder block. Install the camshaft bearing so that the front edge of the bearing is flush with the face of the recess in the cylinder block.

Note: Ensure that the oil holes are correctly aligned. If the oil is not correctly aligned, the camshaft bearing should be removed.

End By:

- a. Install the camshaft. Refer to Disassembly and Assembly, "Camshaft - Remove and Install".
- b. Install the engine oil pump. Refer to Disassembly and Assembly, "Engine Oil Pump - Install".

i04647249

Engine Oil Pan - Remove (Cast Iron Oil Pan)

Removal Procedure

Note: In order to remove a cast iron oil pan, the engine must be removed from the application. Ensure that the engine lubricating oil is drained. Refer to Operation and Maintenance Manual, "Engine Oil and Filter - Change" for the correct procedure.

NOTICE

Keep all parts clean from contaminants.

Contaminants may cause rapid wear and shortened component life.

NOTICE

Care must be taken to ensure that fluids are contained during performance of inspection, maintenance, testing, adjusting and repair of the product. Be prepared to collect the fluid with suitable containers before opening any compartment or disassembling any component containing fluids.

Dispose of all fluids according to local regulations and mandates.

1. The engine should be mounted in a suitable stand and placed in the inverted position.
2. Disconnect the breather hose from the clip that secures the hose to the engine oil pan. Position the breather hose away from the engine oil pan.

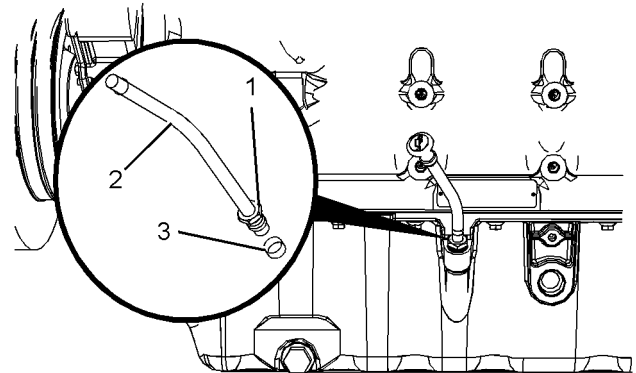

Illustration 203

g02701559

Typical example

3. If necessary, remove the assembly of dipstick tube. Loosen nut (1) and remove tube assembly (2). Remove seal (3) from the tube assembly.

Note: Identify the position and orientation of the tube assembly.

i04472971

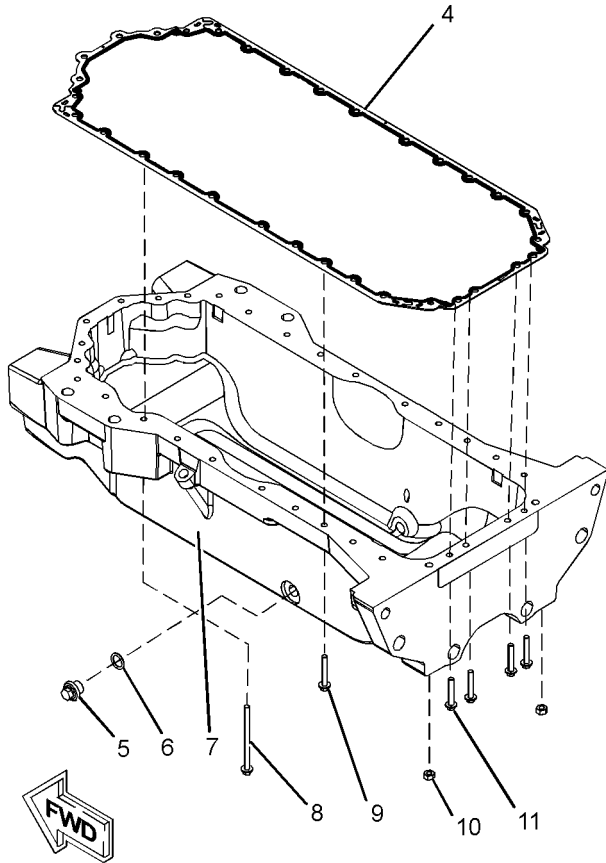

Illustration 204
Typical example

g02789354

4. Attach a suitable lifting device to engine oil pan (7) and support the weight of the engine oil pan. The engine oil pan can weigh 100 kg (220 lb).

5. Remove nuts (10). Remove bolts (8), bolts(11) and bolts (9).

Note: The bolts are different lengths. Note the position of the different bolts.

6. Use the lifting device to remove engine oil pan (7) from the cylinder block.

7. Remove gasket (4) from the cylinder block.

8. Remove drain plug (5).

9. Remove O-ring seal (6) from oil drain plug (5).

Engine Oil Pan - Remove (Aluminum Oil Pan)

Removal Procedure

NOTICE

Keep all parts clean from contaminants.

Contaminants may cause rapid wear and shortened component life.

NOTICE

Care must be taken to ensure that fluids are contained during performance of inspection, maintenance, testing, adjusting and repair of the product. Be prepared to collect the fluid with suitable containers before opening any compartment or disassembling any component containing fluids.

Dispose of all fluids according to local regulations and mandates.

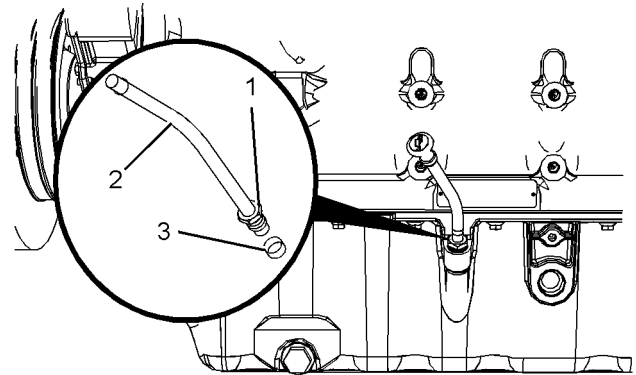

Illustration 205

g02701559

1. If necessary, remove the assembly of dipstick tube. Loosen nut (1) and remove tube assembly (2). remove seal (3) from the tube assembly.

Note: Identify the position and orientation of the tube assembly.

i04647250

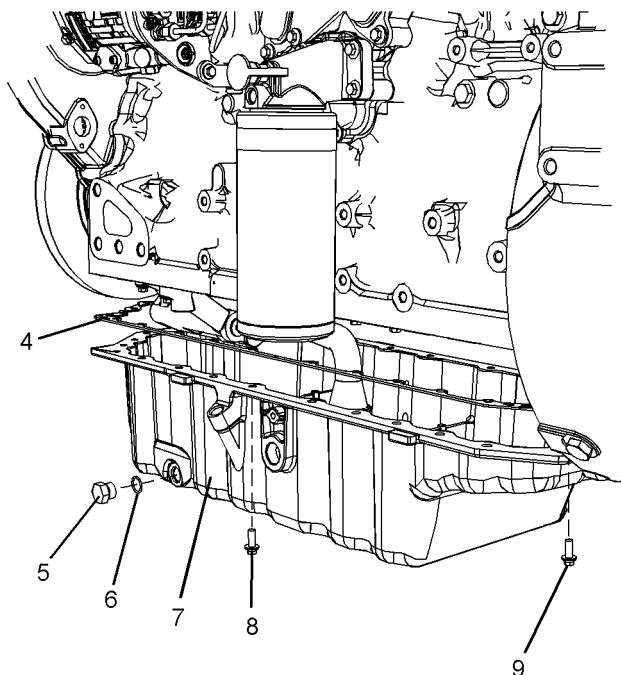

Illustration 206

g02701560

1. Place a suitable container below engine oil pan (7). Remove drain plug (5) and drain the engine lubricating oil. Refer to Operation and Maintenance Manual, "Engine Oil and Filter - Change" for the correct procedure.
2. Remove O-ring seal (6) from drain plug (5).
3. If necessary, disconnect breather hose from the clip that secures the hose to the engine oil pan. Position the breather hose away from the engine oil pan.
4. Support the assembly of engine oil pan (7). Remove bolts (8) and bolts (9). If necessary, mark the position of the clip that secures breather hose. Remove the clip.
5. Remove the assembly of engine oil pan (7) from the engine.

Engine Oil Pan - Install (Cast Iron Oil Pan)

Installation Procedure

Table 57

Required Tools			
Tool	Part Number	Part Description	Qty
A	21826038	POWERPART Silicon Rubber Sealant	-
B	21820117	POWERPART Threadlock and Nutlock	-
C	-	Straight Edge	1

Note: In order to install a cast iron oil pan, the engine must be removed from the application.

NOTICE

Keep all parts clean from contaminants.

Contaminants may cause rapid wear and shortened component life.

NOTICE

Care must be taken to ensure that fluids are contained during performance of inspection, maintenance, testing, adjusting and repair of the product. Be prepared to collect the fluid with suitable containers before opening any compartment or disassembling any component containing fluids.

Dispose of all fluids according to local regulations and mandates.

1. Ensure that the gasket face of the cylinder block is clean and free from damage. Inspect the studs in the cylinder block for damage. If necessary, replace the studs.
2. Ensure that the engine oil pan is clean and free from damage.

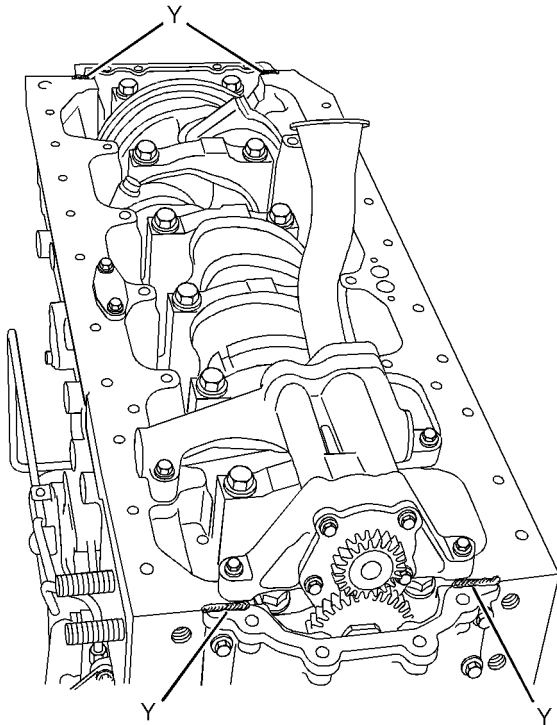

Illustration 207

g01340933

Typical example

3. Apply a bead of Tooling (A) to Positions (Y).

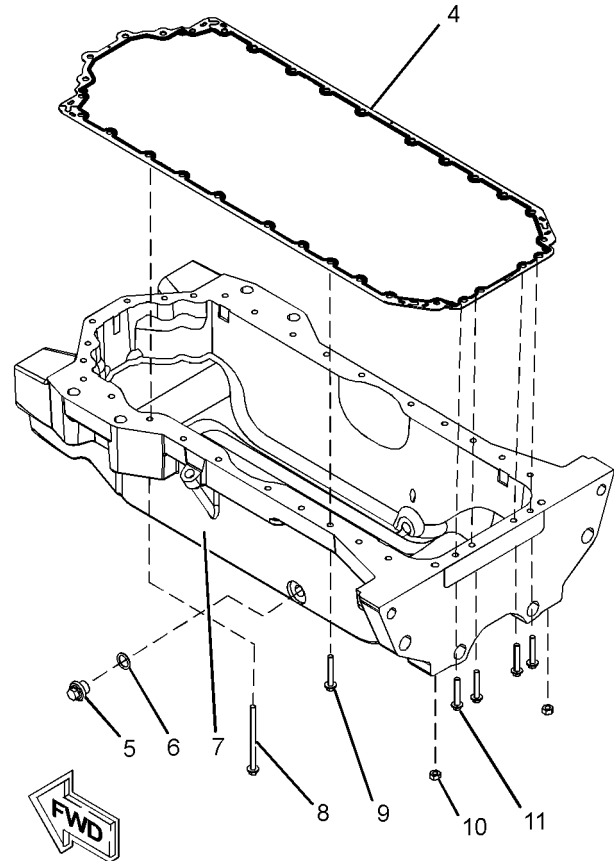

Illustration 208

g02789354

4. Install a new O-ring seal (6) to drain plug (5). Install drain plug (5) to engine oil pan (7). Tighten the drain plug to a torque of 34 N·m (301 lb in).
5. Align a new gasket (4) with the studs and install the gasket to the cylinder block.
6. Attach a suitable lifting device to engine oil pan (7). The engine oil pan can weigh 100 kg (220 lb).
7. Use the lifting device to align engine oil pan (7) with the studs. Install the engine oil pan to the cylinder block.
8. Install nuts (10) finger tight.
9. Install bolts (8), bolts (9) and bolts (11) finger tight.
10. Align the rear face of the engine oil pan to the rear face of the cylinder block. Use Tooling (C) and a feeler gauge in order to check the alignment between the engine oil pan and the cylinder block.

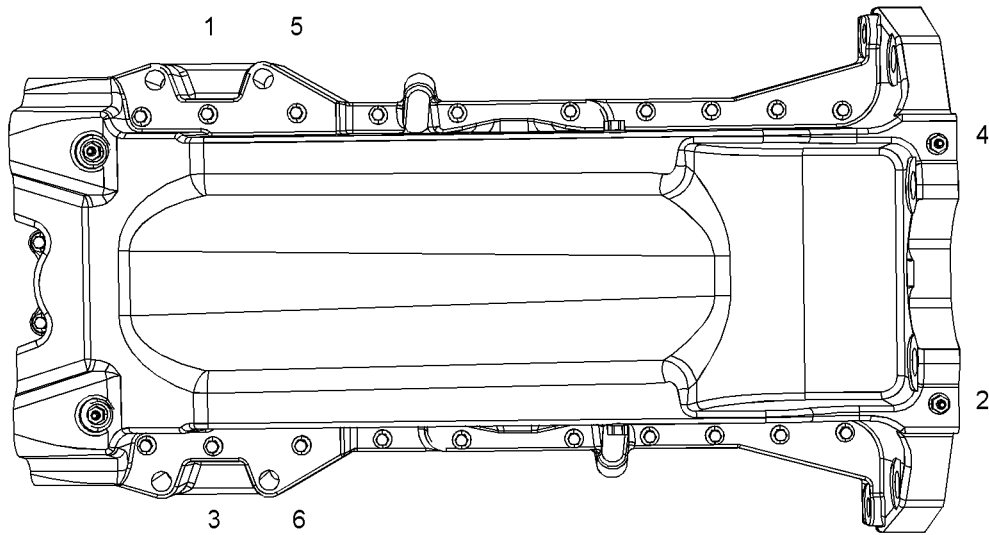

Illustration 209
Typical example

g01340935

11. Tighten bolts (8) and nuts (10) to a torque of 22 N·m (195 lb in). Tighten the fasteners in the sequence that is shown in Illustration 209.

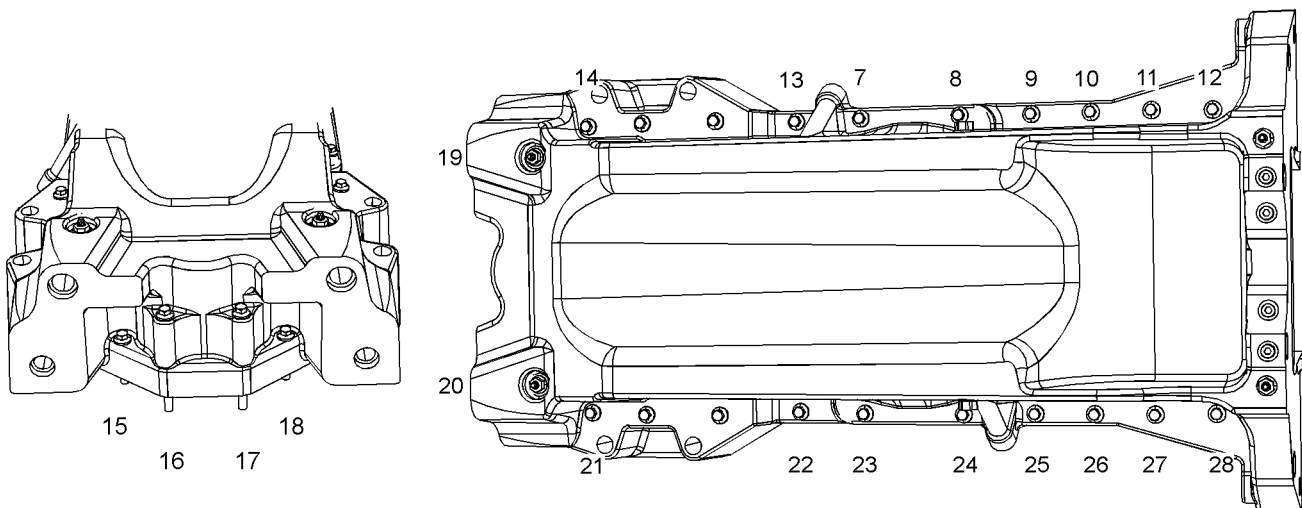

Illustration 210
Typical example

g02789361

12. Tighten bolts (9) and bolts (11) to a torque of 22 N·m (195 lb in). Tighten the bolts in the sequence that is shown in Illustration 210.

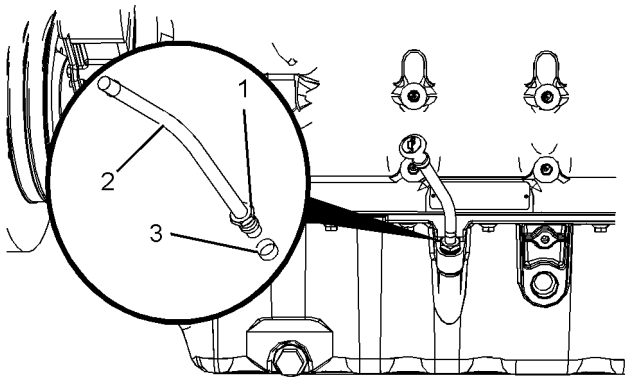

Illustration 211 g02701559
Typical example

13. If necessary, follow Steps 13 through 13.c in order to install the assembly of the dipstick tube.

- a. Install a new seal (3) to tube assembly (2).
- b. Apply Tooling (B) to nut (1). Install the tube assembly to the engine oil pan.

Note: Ensure that the orientation of the tube assembly is correct.

- c. Tighten the nut to a torque of 18 N·m (159 lb in). Install the dipstick.

Note: After the engine has been installed, ensure that the engine oil pan is filled with lubricating oil to the correct level. Refer to Operation and Maintenance Manual, “Oil Filter Change” for the correct procedure.

i04472989

Engine Oil Pan - Install (Aluminum Oil Pan)

Installation Procedure

Table 58

Required Tools			
Tool	Part Number	Part Description	Qty
A	-	Guide Stud (M8 by 100 mm)	4
B	-	Loctite 575 Thread Sealant	1

NOTICE

Keep all parts clean from contaminants.

Contaminants may cause rapid wear and shortened component life.

NOTICE

Care must be taken to ensure that fluids are contained during performance of inspection, maintenance, testing, adjusting and repair of the product. Be prepared to collect the fluid with suitable containers before opening any compartment or disassembling any component containing fluids.

Dispose of all fluids according to local regulations and mandates.

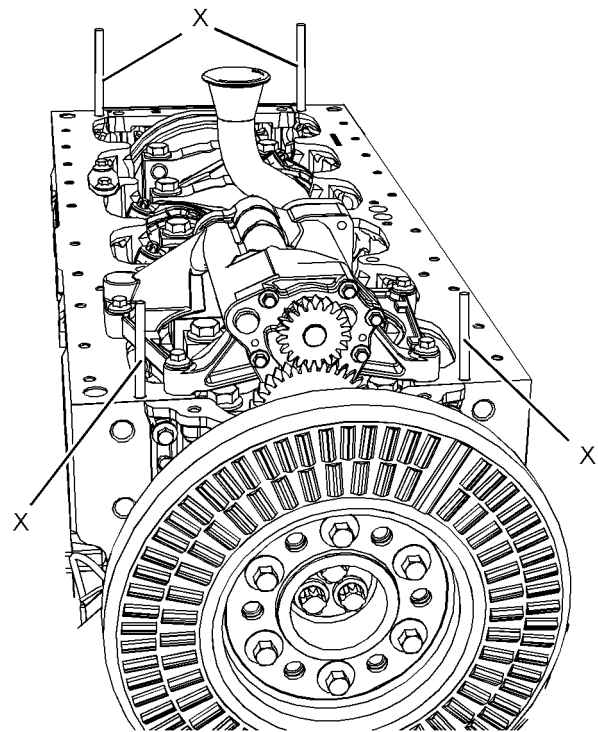

Illustration 212 g02701596

- 1. Install Tooling (A) to Positions (X) in the cylinder block.

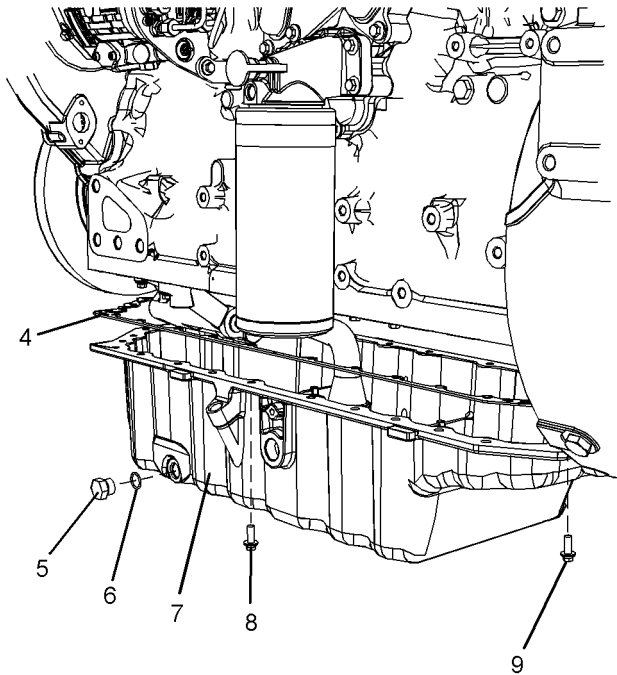

Illustration 213

g02701560

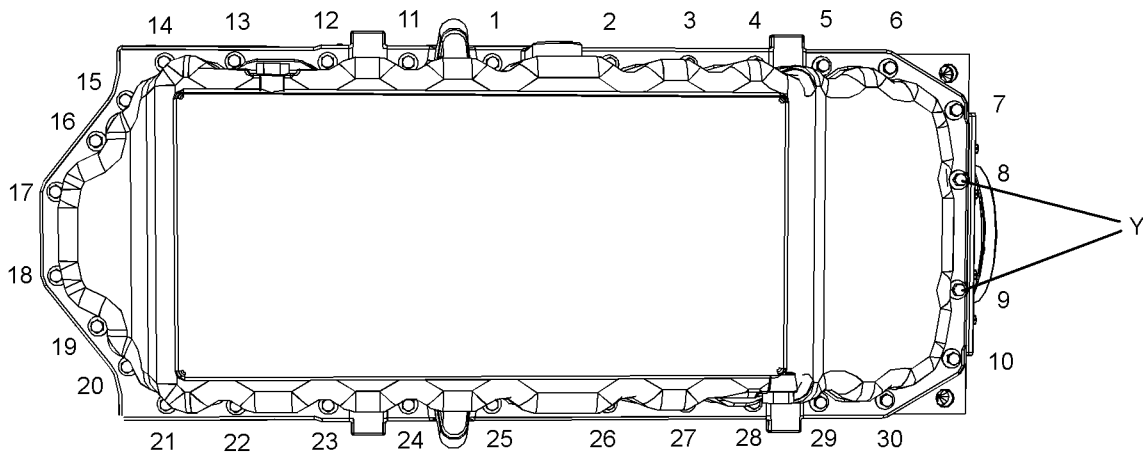

Illustration 214

g02701616

Engine oil pan tightening sequence

2. Ensure that engine oil pan (7) is clean and free from damage.
3. Position a new gasket (4) onto engine oil pan (7).
4. Align the assembly of engine oil pan (7) with Tooling (A).
5. Install bolts (8) to engine oil pan (7) finger tight.
6. Install new bolts (9) to engine oil pan (7) in Position (Y) hand tight.
7. Remove Tooling (A).
8. Install remaining bolts (8).
9. Tighten bolts (8) and bolts (9) to a torque of 22 N·m (195 lb in). Tighten the bolts in the sequence that is shown in Illustration 214.

i04473063

10. Install a new O-ring seal (6) to drain plug (5). Install drain plug (5) to engine oil pan (7). Refer to Illustration 213. Tighten the oil drain plug to a torque of 34 N·m (301 lb in).

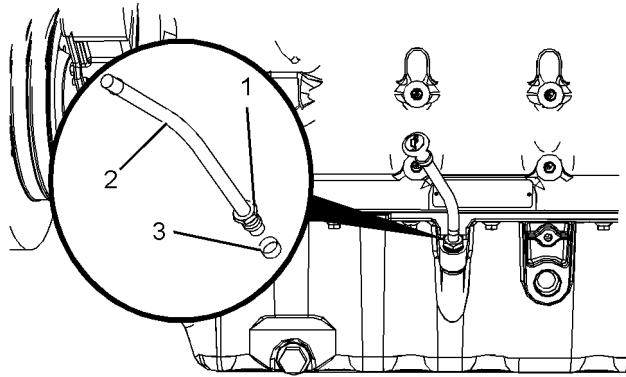

Illustration 215

g02701559

11. If necessary, follow Steps 11.a through 11.c in order to install the assembly of the dipstick tube.
- a. Install a new seal (3) to tube assembly (2).
 - b. Apply Tooling (B) to nut (1). Install the tube assembly to the engine oil pan.
- Note:** Ensure that the orientation of the tube assembly is correct.
- c. Tighten nut (1) to a torque of 18 N·m (159 lb in). Install the dipstick.
12. Fill the engine oil pan to the correct level. Refer to Operation and Maintenance Manual, “Oil Filter Change” for the procedure.

Piston Cooling Jets - Remove and Install

Removal Procedure

Table 59

Required Tools			
Tool	Part Number	Part Description	Qty
A ⁽¹⁾	T400011	Crankshaft Turning Tool	1
A ⁽²⁾	27610291	Housing	1
	27610289	Engine Turning Tool	1

⁽¹⁾ The Crankshaft Turning Tool is used on the front pulley.

⁽²⁾ This Tool is used in the aperture for the electric starting motor.

Start By:

- a. Remove the engine oil pump. Refer to Disassembly and Assembly, “Engine Oil Pump - Remove” for the correct procedure.

Note: Either Tooling (A) can be used. Use the Tooling that is most suitable.

NOTICE

Keep all parts clean from contaminants.

Contaminants may cause rapid wear and shortened component life.

- 1. If the crankshaft is installed, use Tooling (A) to rotate the crankshaft in order to gain access to the piston cooling jet.

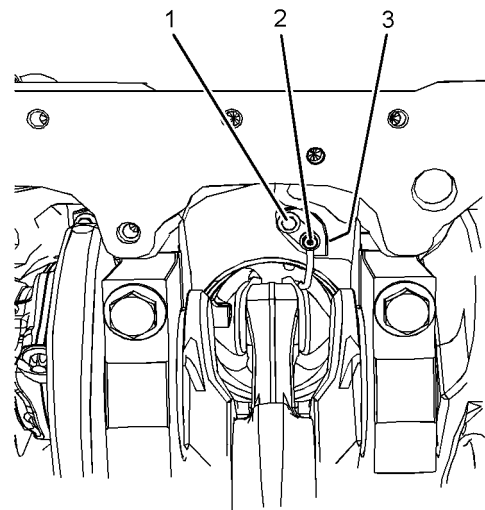

Illustration 216

g02011713

2. Remove bolt (1) and piston cooling jet (2) from the cylinder block. Remove O-ring seal (3) (not shown).
3. Repeat Step 1 through Step 2 in order to remove the remaining piston cooling jets.

Installation Procedure

Table 60

Required Tools			
Tool	Part Number	Part Description	Qty
A ⁽¹⁾	T400011	Crankshaft Turning Tool	1
A ⁽²⁾	27610291	Housing	1
	27610289	Engine Turning Tool	1

- (1) The Crankshaft Turning Tool is used on the front pulley.
 (2) This Tool is used in the aperture for the electric starting motor.

Note: Either Tooling (A) can be used. Use the Tooling that is most suitable.

NOTICE

Keep all parts clean from contaminants.

Contaminants may cause rapid wear and shortened component life.

2. If the crankshaft is installed, use Tooling (A) to rotate the crankshaft in order to access the mounting flange for the piston cooling jet.
3. Install a new O-ring seal (3) (not shown) onto piston cooling jet (2).
4. Install piston cooling jet (2) into the oil passage in the cylinder block.

Note: Ensure that the piston cooling jet is correctly installed into the oil passage in the cylinder block before tightening the bolt.

5. Install bolt (1). Tighten the bolt to a torque of 9 N·m (80 lb in).
6. Repeat Step 2 through Step 4 in order to install the remaining piston cooling jets.

End By:

- a. Install the engine oil pump. Refer to Disassembly and Assembly, "Engine Oil Pump - Install" for the correct procedure.

i04473067

Pistons and Connecting Rods - Remove

Removal Procedure

Table 61

Required Tools			
Tool	Part Number	Part Description	Qty
A ⁽¹⁾	T400011	Crankshaft Turning Tool	1
A ⁽²⁾	27610291	Housing	1
	27610289	Engine Turning Tool	1
B	27610274	Ridge Reamer	1
C	-	E12 Torx Socket	1

- (1) The Crankshaft Turning Tool is used on the front pulley.
 (2) This Tool is used in the aperture for the electric starting motor.

Start By:

- a. Remove the cylinder head. Refer to Disassembly and Assembly, "Cylinder Head - Remove" for the correct procedure.
- b. Remove the piston cooling jets. Refer to Disassembly and Assembly, "Piston Cooling Jets - Remove and Install" for the correct procedure.

Note: Either Tooling (A) can be used. Use the Tooling that is most suitable.

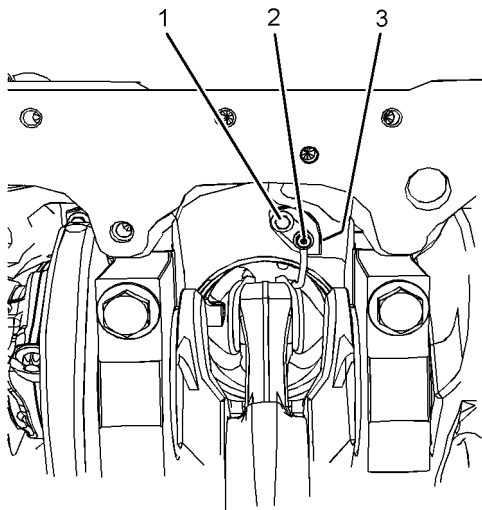

Illustration 217

g02011713

1. Clean the piston cooling jets and inspect the piston cooling jets for damage. Ensure that the valve is free to move within each piston cooling jet. Replace any damaged piston cooling jets. The procedure for checking that the alignment of the piston cooling jets is described in Specifications, "Piston Cooling Jet Alignment" for more information.

NOTICE

Keep all parts clean from contaminants.

Contaminants may cause rapid wear and shortened component life.

1. Use Tooling (A) to rotate the crankshaft until the crank pin is at the bottom center position.
2. Use Tooling (B) to remove the carbon ridge from the top inside surface of the cylinder bore.

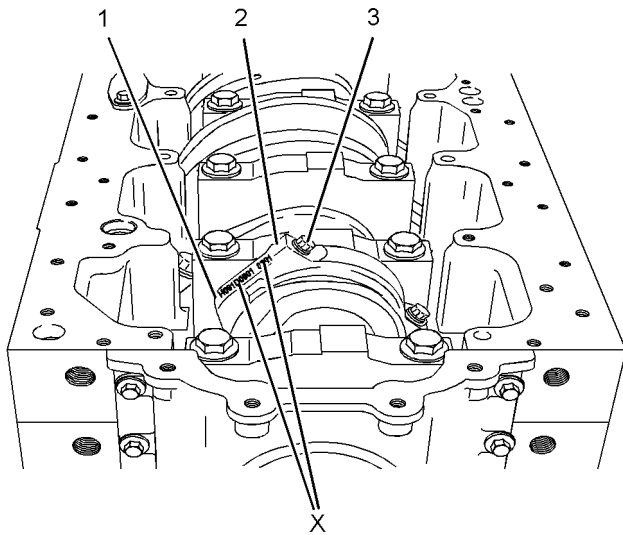

Illustration 218

g02411576

3. The connecting rod and the connecting rod cap should have an etched number in Position (X) on the side. The number on the connecting rod and the connecting rod cap must match. Ensure that connecting rod (1) and connecting rod cap (2) are marked for the correct location. If necessary, make a temporary mark on the connecting rod and the connecting rod cap in order to identify the cylinder number.

Note: Do not stamp the connecting rod assembly. Stamping or punching the connecting rod assembly could cause the connecting rod to fracture.

4. Use Tooling (C) to remove bolts (3). Remove connecting rod cap (2) from connecting rod (1).

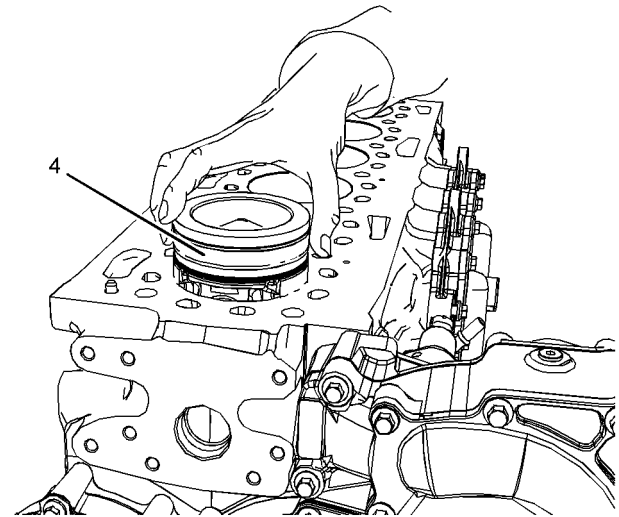

Illustration 219

g02013134

5. Carefully push piston (4) and the connecting rod out of the cylinder bore. Lift piston (4) out of the top of the cylinder block.

Note: Do not push on the fracture split surfaces of the connecting rod as damage may result.

6. Repeat Step 1 through Step 5 for the remaining pistons and connecting rods.

Note: Fracture split connecting rods should not be left without the connecting rod caps installed. Temporarily install connecting rod cap (2) and bolts (3) to connecting rod (1) when the assembly is out of the engine. Ensure that the etched number on connecting rod matches the etched number on connecting rod cap. Ensure the correct orientation of the connecting rod cap. The locating tab for the upper bearing shell and the lower bearing shell should be on the same side. Tighten bolts (3) to a torque of 20 N·m (177 lb in).

i04473065

Pistons and Connecting Rods - Disassemble

Disassembly Procedure

Table 62

Required Tools			
Tool	Part Number	Part Description	Qty
A	-	Retaining Ring Pliers	1
B	-	Ring Expander	1

Start By:

- a. Remove the pistons and the connecting rods. Refer to Disassembly and Assembly, "Piston and Connecting Rods - Remove" for the correct procedure.

Note: Make a temporary mark on the components of the piston and connecting rod assembly. Making temporary marks will ensure that the components of each piston and connecting rod assembly can be reinstalled in the original cylinder. Mark the underside of the piston on the front pin boss. Do not interchange components.

NOTICE

Keep all parts clean from contaminants.

Contaminants may cause rapid wear and shortened component life.

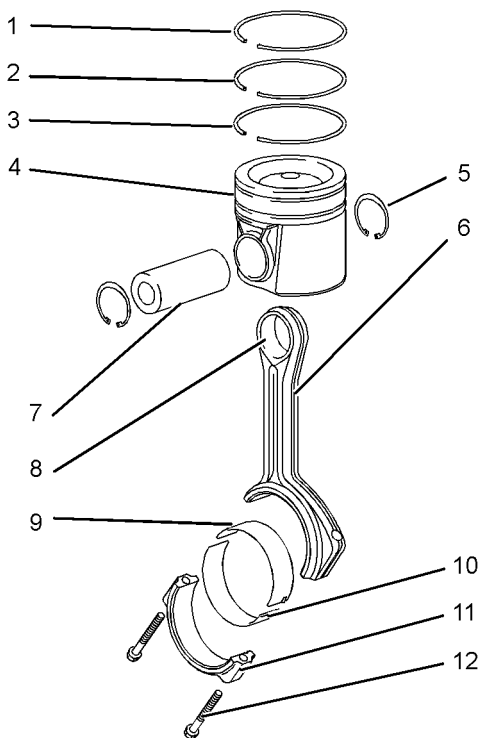

Illustration 220

g01341306

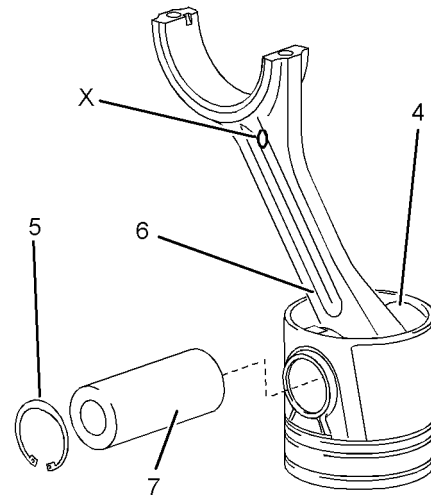

Illustration 221

g02383077

1. Remove bolts (12) and connecting rod cap (11) from connecting rod (6). Discard the bolts.

Note: Fracture split connecting rods should not be left without the connecting rod caps installed. After the disassembly procedure for the piston and connecting rod is completed, carry out the assembly procedure and the installation procedure as soon as possible. Refer to Disassembly and Assembly, "Piston and Connecting Rods - Assemble" and Disassembly and Assembly, "Piston and Connecting Rods - Install" for the correct procedure.

2. Remove lower bearing shell (10) from connecting rod cap (11). Remove upper bearing shell (9) from connecting rod (6). Keep the bearing shells together.
3. Place the piston and connecting rod assembly on a suitable surface with the connecting rod upward. Use Tooling (A) in order to remove circlips (5).

Note: Note the position of forged Mark (X). The forged mark is for the purposes of correct orientation of the connecting rod assembly and piston assembly.

4. Remove piston pin (7) and connecting rod (6) from piston (4).

Note: If the piston pin cannot be removed by hand, heat the piston to a temperature of $45 \pm 5 \text{ }^\circ\text{C}$ ($113 \pm 9 \text{ }^\circ\text{F}$). Do not use a torch to heat the piston. Note the orientation of connecting rod (6) and piston (4).

5. Place the piston on a suitable surface with the crown upward. Use Tooling (B) in order to remove compression ring (1) and compression ring (2), and oil control ring (3) from piston (4).

Note: Make temporary identification marks to identify the position and orientation of compression ring (1) and compression ring (2), and oil control ring (3).

NOTICE

Removal of the piston pin bushing in the connecting rod must be carried out by personnel with the correct training. Also special machinery is required. For more information refer to your authorized Perkins dealer.

- 6. Inspect the connecting rod for wear and damage. If necessary, replace connecting rod (6) or replace bushing (8) for piston pin (7).

Note: If the connecting rod or the bushing for the piston pin are replaced, refer to Specifications, "Connecting Rods" for more information.

- 7. Repeat Step 1 through Step 6 in order to disassemble the remaining pistons and connecting rods.

i04473064

Pistons and Connecting Rods - Assemble

Assembly Procedure

Table 63

Required Tools			
Tool	Part Number	Part Description	Qty
A	-	Retaining Ring Pliers	1
B	-	Ring Expander	1

NOTICE

Keep all parts clean from contaminants.

Contaminants may cause rapid wear and shortened component life.

- 1. Ensure that all components are clean and free from wear and damage. If necessary, replace any components that are worn or damaged.

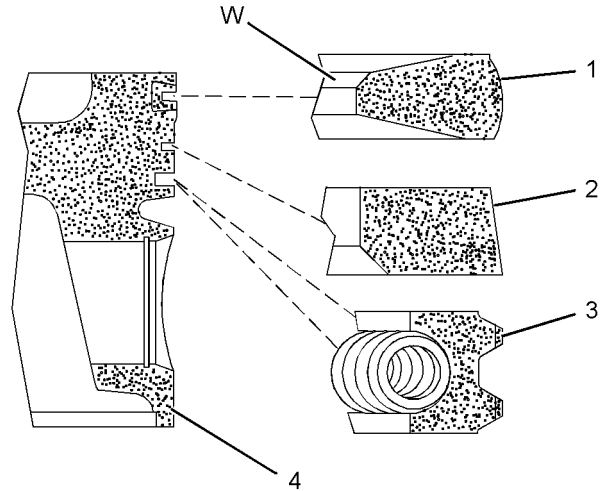

Illustration 222

g02319675

- 2. If the original piston and rings are to be reused, follow Step 2.a through Step 2.e in order to install the piston rings to the piston.

- a. Position the spring for oil control ring (3) into the oil ring groove in piston (4). The central wire must be located inside the end of the spring.
- b. Position the oil control ring with the word "TOP" in the upward position. Use Tooling (B) to install oil control ring (3) over the piston and the spring.

Note: Ensure that the central wire is 180 degrees from the ring gap.

- c. Use Tooling (B) to install intermediate compression ring (2) into the second groove in piston (4). The word "TOP" must be upward. The chamfer on the inner face must be downward.

- d. Use Tooling (B) to install top compression ring (1) into the top groove in piston (4). The word "TOP" must be upward.

Note: Ensure that the top compression ring is installed with Chamfer (W) in the upward position.

- e. Position the piston ring gaps at approximately 120 degrees away from each other.

Note: A new piston assembly is supplied with new piston rings.

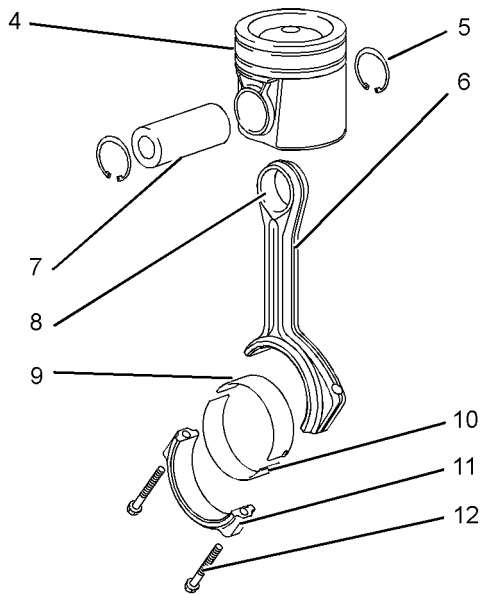

Illustration 223

g02210673

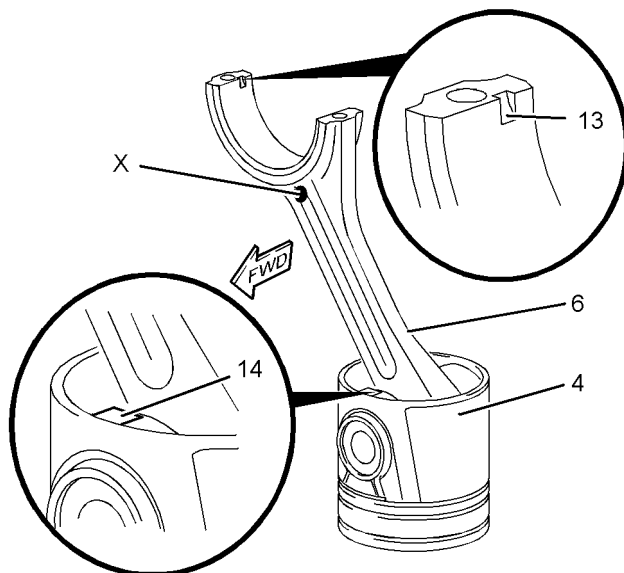

Illustration 224

g02090053

NOTICE

Removal of the piston pin bushing in the connecting rod must be carried out by personnel with the correct training. Also special machinery is required. For more information refer to your authorized Perkins dealer.

3. If connecting rod assembly (6), bushing (8), and piston pin (7) are replaced, refer to Specifications, "Connecting Rods" for more information.

4. Lubricate bushing (8) for piston pin (7) in the connecting rod with clean engine oil. Lubricate the bore for the piston pin in piston (4) with clean engine oil.
5. Place piston (4) on a suitable surface with the crown downward. Position connecting rod (6) with forged Mark (X) to square boss (14) on the piston. Ensure that slot (13) on the connecting rod is in the correct position. See Illustration 224.
6. Install piston pin (7) to piston (4).

Note: If the piston pin cannot be installed by hand, heat the piston to a temperature of $45^{\circ} \pm 5^{\circ}\text{C}$ ($113^{\circ} \pm 9^{\circ}\text{F}$).

7. Use Tooling (A) in order to install circlips (5) to the piston pin bore in piston (4).

Note: Ensure that the circlips are seated in the grooves in the piston.

8. Install upper bearing shell (9) into connecting rod (6). Ensure that the locating tab for the upper bearing shell is correctly seated in slot (13) in the connecting rod.
9. Install lower bearing shell (10) into connecting rod cap (11). Ensure that the locating tab for the lower bearing shell is correctly seated in the slot in the connecting rod cap.
10. Fracture split connecting rods should not be left without the connecting rod caps installed. Temporarily install connecting rod cap (11) and bolts (12) to connecting rod (6) when the assembly is out of the engine. Ensure that the etched number on connecting rod cap matches the etched number on connecting rod. Ensure the correct orientation of the connecting rod cap. The locating tab for the upper bearing shell and the lower bearing shell should be on the same side. Tighten bolts (12) to a torque of 20 N·m (177 lb in).
11. Repeat Step 2 through Step 10 for the remaining piston and connecting rod assemblies.

End By:

- a. Install the pistons and the connecting rods. Refer to Disassembly and Assembly, "Piston and Connecting Rods - Install" for the correct procedure.

i04473066

Pistons and Connecting Rods - Install

Installation Procedure

Table 64

Required Tools			
Tool	Part Number	Part Description	Qty
A ⁽¹⁾	T400011	Crankshaft Turning Tool	1
A ⁽²⁾	27610291	Housing	1
	27610289	Engine Turning Tool	1
B	21825491	Piston Ring Compressor	1
C	-	E12 Torx Socket	1
D	21825607	Degree Wheel	1

⁽¹⁾ The Crankshaft Turning Tool is used on the front pulley.

⁽²⁾ This Tool is used in the aperture for the electric starting motor.

Note: Either Tooling (A) can be used. Use the Tooling that is most suitable.

NOTICE

Keep all parts clean from contaminants.

Contaminants may cause rapid wear and shortened component life.

NOTICE

Discard all used Connecting Rod fasteners.

1. If the connecting rod caps were temporarily installed, remove the connecting rod caps. If necessary, thoroughly clean all of the components.
2. Apply clean engine oil to the cylinder bore, piston rings, outer surface of the piston, and the bearing shells for the connecting rod.

Note: Install the bearing shells for the connecting rods dry when clearance checks are performed. Refer to Disassembly and Assembly, "Bearing Clearance - Check" for the correct procedure. Apply clean engine oil to the bearing shells for the connecting rods during final assembly.

Note: Ensure that the piston and the connecting rod assembly are installed in the correct cylinder.

3. Use Tooling (A) to rotate the crankshaft until the crankshaft pin is at the bottom center position. Lubricate the crankshaft pin with clean engine oil.

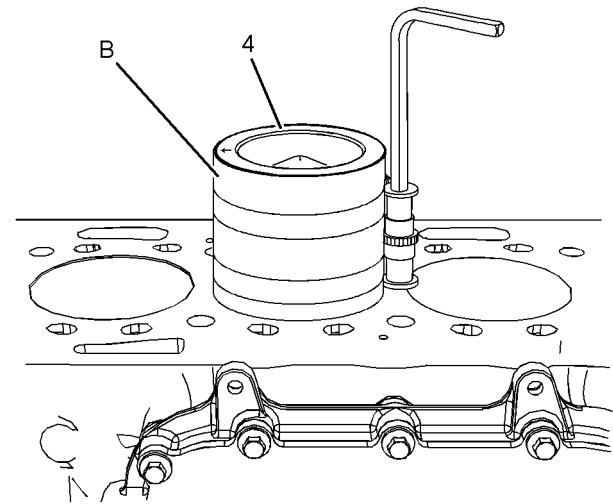

Illustration 225

g02013213

4. Install Tooling (B) onto piston (4).

Note: Ensure that Tooling (B) is installed correctly and that piston (4) can easily slide from the tool.

Note: The locating tab for the bearing shell of the connecting rod must be on the same side of the engine as the piston cooling jet.

5. Carefully push the piston and the connecting rod assembly into the cylinder bore and onto the crankshaft pin.

Note: Do not damage the finished surface of the crankshaft pin.

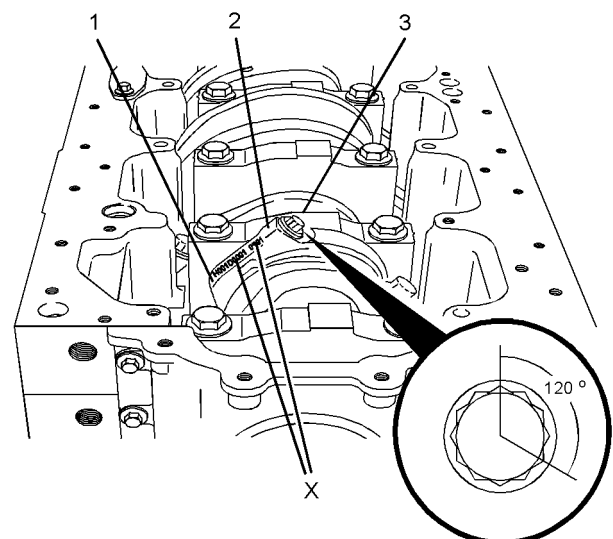

Illustration 226

g02383096

6. Install connecting rod cap (2) onto connecting rod (1).

Note: Ensure that etched number in Position (X) on connecting rod cap (2) matches etched number in Position (X) on connecting rod (1). Ensure the correct orientation of connecting rod cap (2). The locating tab for the upper bearing shell and the lower bearing shell should be on the same side.

Note: Do not reuse the old bolts in order to secure the connecting rod cap.

7. Install new bolts (3) to connecting rod (1). Use Tooling (C) in order to tighten the bolts evenly to a torque of 40 N·m (30 lb ft).
8. Turn the bolts for an additional 120 degrees in a clockwise direction. Use Tooling (C) and Tooling (D) to achieve the correct final torque.
9. Ensure that the installed connecting rod assembly has tactile side play. Rotate the crankshaft in order to ensure that there is no binding.
10. Repeat Step 2 through Step 9 in order to install the remaining pistons and connecting rods.

End By:

- a. Install the piston cooling jets. Refer to Disassembly and Assembly, “Piston Cooling Jets - Remove and Install” for the correct procedure.
- b. Install the cylinder head. Refer to Disassembly and Assembly, “Cylinder Head - Install” for the correct procedure.

i04472953

Connecting Rod Bearings - Remove (Connecting Rods in Position)

Removal Procedure

Table 65

Required Tools			
Tool	Part Number	Part Description	Qty
A ⁽¹⁾	T400011	Crankshaft Turning Tool	1
A ⁽²⁾	27610291	Housing	1
	27610289	Engine Turning Tool	1
B	-	E12 Torx Socket	1

(1) The Crankshaft Turning Tool is used on the front pulley.

(2) This Tool is used in the aperture for the electric starting motor.

Start By:

- a. Remove the engine oil pump. Refer to Disassembly and Assembly, “Engine Oil Pump - Remove” for the correct procedure.

Note: Either Tooling (A) can be used. Use the Tooling that is most suitable.

NOTICE

Keep all parts clean from contaminants.

Contaminants may cause rapid wear and shortened component life.

NOTICE

Discard all used Connecting Rod fasteners.

Note: If all connecting rod bearings require replacement, the procedure can be carried out on two cylinders at the same time. The procedure can be carried out on the following pairs of cylinders. 1 with 6, 2 with 5, and 3 with 4. **Ensure that both pairs of the connecting rod bearings are installed before changing from one pair of cylinders to another pair of cylinders.** Refer to Disassembly and Assembly, “Connecting Rod Bearings - Install” for the correct procedure.

1. Use Tooling (A) to rotate the crankshaft until the crankshaft pins are at the bottom center position.

If necessary, remove the glow plugs. Ref to Disassembly and Assembly, “Glow Plugs - Remove and Install” for the correct procedure.

Note: Removal of the glow plugs aids removal of the connecting rod bearing. Removal of the glow plugs is not essential.

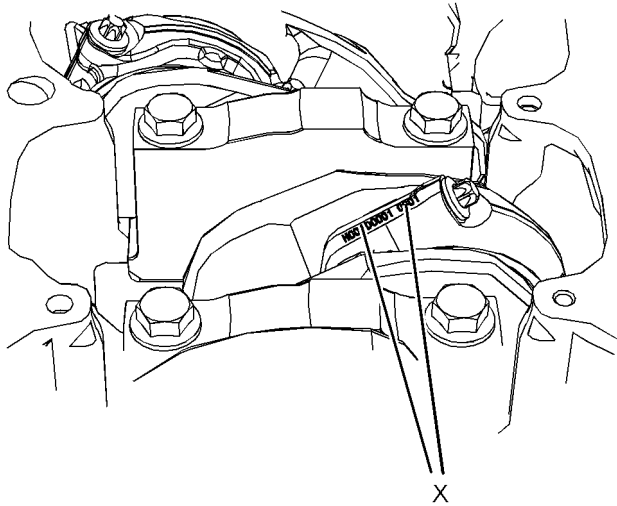

Illustration 227 g02319916
Etched number in Position (X)

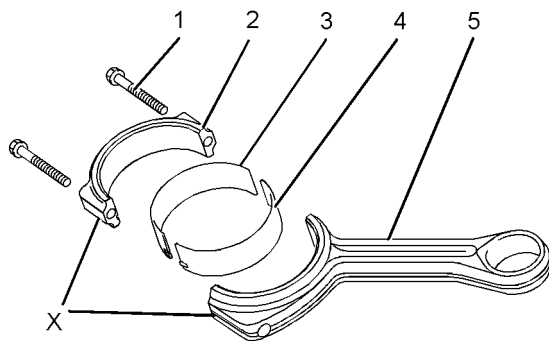

Illustration 228 g01341322

2. The connecting rods and the connecting rod caps should have an etched number in Positions (X). The number on the connecting rod and the connecting rod cap must match. If necessary, make a temporary mark on connecting rods (5) and connecting rod caps (2) in order to identify the cylinder number.

Note: Do not punch identification marks onto fracture split connecting rods. Do not stamp identification marks onto fracture split connecting rods.

3. Use Tooling (B) in order to remove bolts (1).
Discard bolts (1).
4. Remove connecting rod cap (2) from connecting rod (5).
5. Remove lower bearing shell (3) from connecting rod cap (2). Keep the bearing shell and the connecting rod cap together.

6. Carefully push connecting rod (5) into the cylinder bore until connecting rod (5) is clear of the crankshaft. Remove upper bearing shell (4) from the connecting rod. Keep the bearing shells together.

Note: Do not push on the fracture split surfaces of the connecting rod as damage may result. Do not allow the connecting rod to contact the piston cooling jet.

7. Repeat Step 1 through Step 6 in order to remove the remaining bearing shells.

Note: Fracture split connecting rods should not be left without the connecting rod caps installed. After the removal procedure for the bearing shells is complete, carry out the installation procedure as soon as possible. Refer to Disassembly and Assembly, "Connecting Rod Bearings - Install" for the correct procedure.

i04472952

Connecting Rod Bearings - Install (Connecting Rods in Position)

Installation Procedure

Table 66

Required Tools			
Tool	Part Number	Part Description	Qty
A ⁽¹⁾	T400011	Crankshaft Turning Tool	1
A ⁽²⁾	27610291	Housing	1
	27610289	Engine Turning Tool	1
B	-	E12 Torx Socket	1
C	21825607	Degree Wheel	1

(1) The Crankshaft Turning Tool is used on the front pulley.

(2) This Tool is used in the aperture for the electric starting motor.

Note: Either Tooling (A) can be used. Use the Tooling that is most suitable.

NOTICE

Keep all parts clean from contaminants.

Contaminants may cause rapid wear and shortened component life.

NOTICE

Discard all used Connecting Rod fasteners.

1. Inspect the pins of the crankshaft for damage. If the crankshaft is damaged, replace the crankshaft. Refer to Disassembly and Assembly, "Crankshaft - Remove" and Disassembly and Assembly, "Crankshaft - Install" for the correct procedure. Ensure that the bearing shells are clean and free from wear and damage. If necessary, replace the bearing shells.

Note: If the bearing shells are replaced, check whether oversize bearing shells were previously installed.

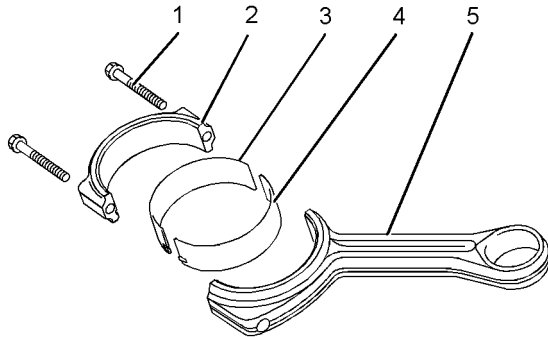

Illustration 229

g02015553

2. Install upper bearing shell (4) into connecting rod (5). Ensure that the locating tab for the upper bearing shell is correctly seated in the slot in the connecting rod.

Note: The ends of the upper bearing shell must be centered in the connecting rod. The ends of the upper bearing shell must be equally positioned in relation to the mating faces of the connecting rod.

3. Lubricate upper bearing shell (4) with clean engine oil.
4. Use Tooling (A) to rotate the crankshaft until the crankshaft pins is at the bottom dead center position.
5. Carefully pull connecting rod (5) against the crankshaft pin.

Note: Do not allow the connecting rod to contact the piston cooling jet.

6. Clean connecting rod cap (2). Install lower bearing shell (3) into connecting rod cap (2). Ensure that the locating tab for the lower bearing shell is correctly seated in the slot in the connecting rod cap.
7. Lubricate the pin of the crankshaft and lubricate lower bearing shell (3) with clean engine oil.

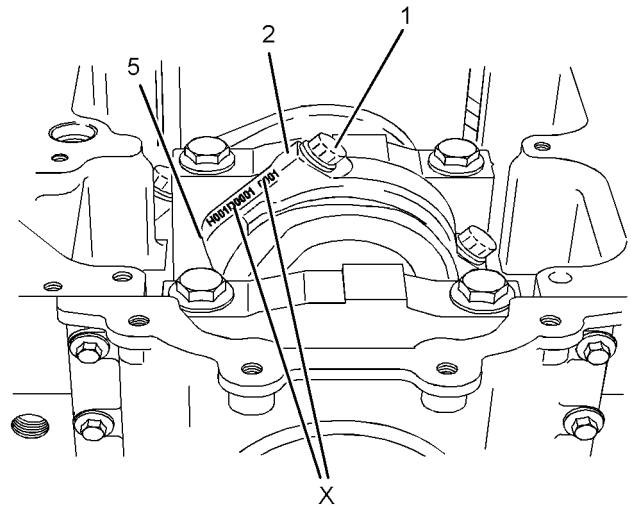

Illustration 230

g02411597

Etched number in Position (X)

8. Install connecting rod cap (2) to connecting rod (5).

Note: Ensure that etched number in Position (X) on connecting rod cap (2) matches etched number in Position (X) on connecting rod (5). Ensure the correct orientation of the connecting rod cap. The locating tab for the upper bearing shell and the lower bearing shell should be on the same side.

Note: Do not reuse the old bolts in order to secure the connecting rod cap.

9. Use Tooling (B) in order to install new bolts (1) to the connecting rod. Tighten the bolts evenly to a torque of 40 N·m (30 lb ft).
10. Turn the bolts through an additional 120 degrees in a clockwise direction. Use Tooling (B) and Tooling (C) to achieve the correct final torque.
11. Ensure that the installed connecting rod assembly has tactile side play. Rotate the crankshaft in order to ensure that there is no binding.
12. Repeat Step 2 through Step 11 in order to install the remaining connecting rod bearings.

Note: If all connecting rod bearings require replacement, the procedure can be carried out on two cylinders at the same time. The procedure can be carried out on the following pairs of cylinders. 1 with 6, 2 with 5, and 3 with 4. **Ensure that both pairs of the connecting rod bearings are installed before changing from one pair of cylinders to another pair of cylinders.** Refer to Disassembly and Assembly, "Connecting Rod Bearings - Install" for the correct procedure.

13. If the glow plugs were removed, install the glow plugs. Ref to Disassembly and Assembly, "Glow Plugs - Remove and Install" for the correct procedure.

End By:

a. Install the engine oil pump. Refer to Disassembly and Assembly, "Engine Oil Pump - Install" for the correct procedure.

i04472962

Crankshaft Main Bearings - Remove and Install (Crankshaft in Position)

Removal Procedure

Table 67

Required Tools			
Tool	Part Number	Part Description	Qty
A	T400011	Crankshaft Turning Tool	1

Start By:

- a. Remove the engine oil pump. Refer to Disassembly and Assembly, "Engine Oil Pump - Remove" for the correct procedure.
- b. Remove the crankshaft rear seal. Refer to Disassembly and Assembly, "Crankshaft Rear Seal - Remove" for the correct procedure.

NOTICE

This procedure must only be used to remove and install the main bearing shells with the crankshaft in position.

The removal procedure and the installation procedure must be completed for each pair of main bearing shells before the next pair of main bearing shells are removed.

NOTICE

Keep all parts clean from contaminants.

Contaminants may cause rapid wear and shortened component life.

1. Ensure that the main bearing cap is marked for the correct location and orientation.

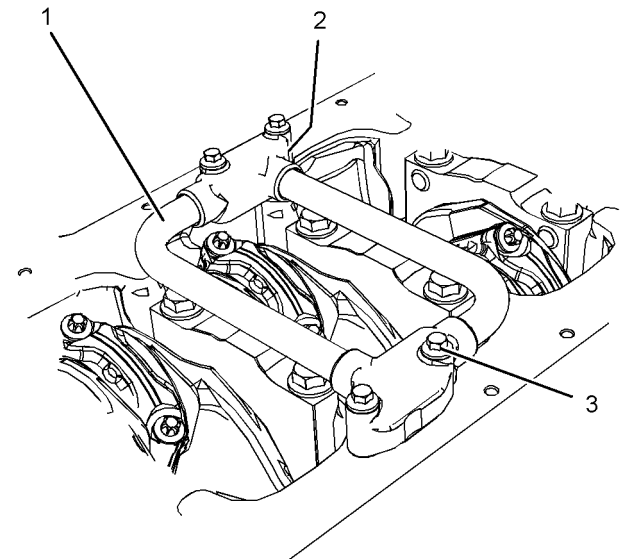

Illustration 231

g02724705

Typical example

2. If necessary, follow Step 2.a through Step 2.c in order to remove the cross over tube assembly from the cylinder block.
 - a. Remove bolts (3) from tube assembly (1).
 - b. Remove tube assembly (1) from the cylinder block.
 - c. Remove gaskets (2) (not shown).

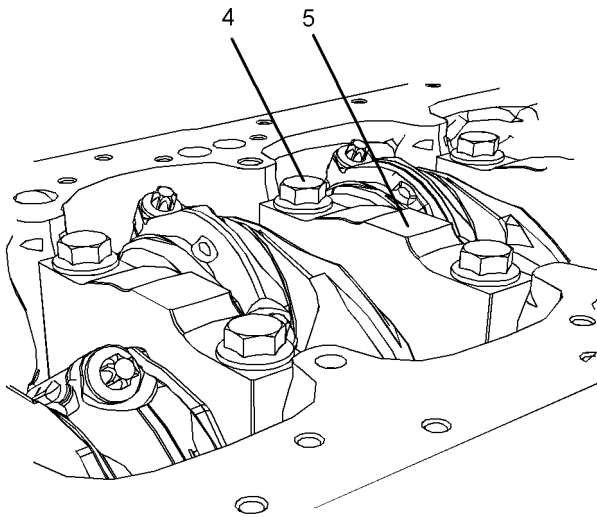

Illustration 232

g02204373

3. Remove bolts (4) and remove main bearing cap (5) from the cylinder block.

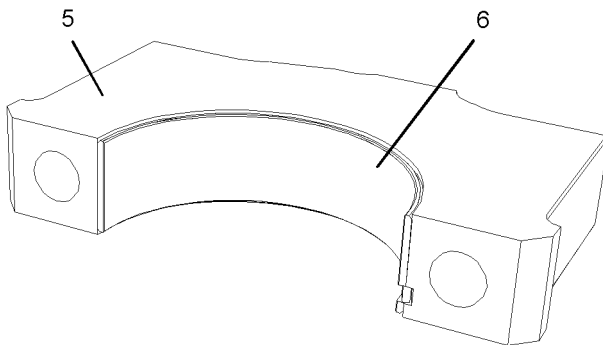

Illustration 233

g02204374

4. Remove lower main bearing shell (6) from main bearing cap (5). Keep the main bearing shell and the main bearing cap together.

Note: The lower main bearing shell is a plain bearing that has no oil holes.

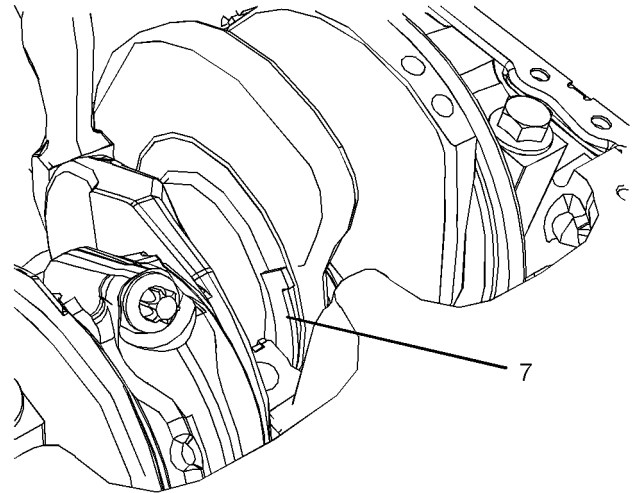

Illustration 234

g02711917

5. For number six main bearing, remove two thrust washers (7) from the cylinder block. In order to remove thrust washers (7), use Tooling (A) to rotate the crankshaft in the correct direction. If necessary, push the crankshaft toward the front of the engine or push the crankshaft toward the rear of the engine while you rotate the crankshaft, in order to aid removal.

Note: The thrust washers have a locating tab at one end.

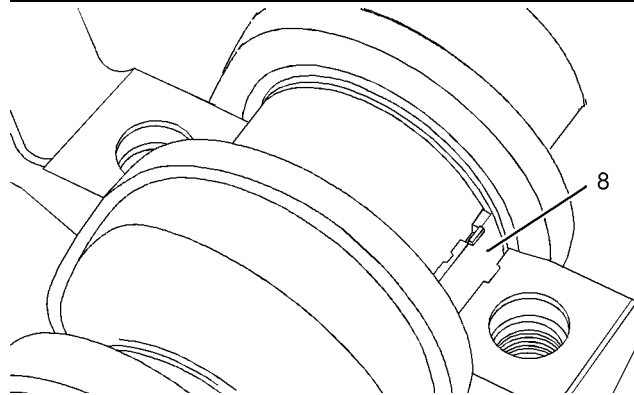

Illustration 235

g02204376

6. Push out upper main bearing shell (8) with a suitable tool from the side opposite the locating tab. Carefully rotate the crankshaft while you push on the bearing shell. Remove upper main bearing shell (8) from the cylinder block. Keep the bearing shells together.

Note: The upper main bearing shell has a groove and two oil holes.

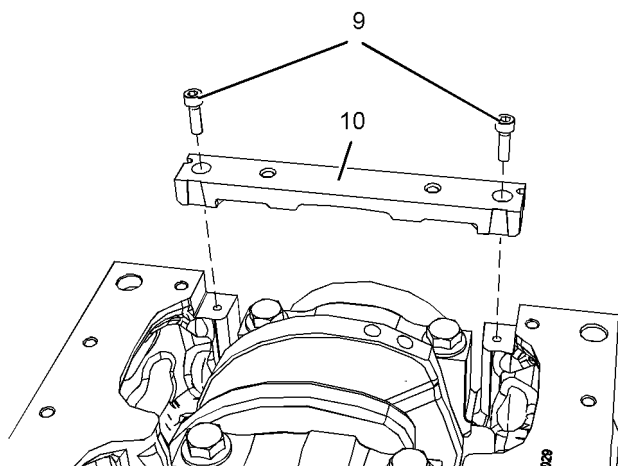

Illustration 236

g02724722

7. In order to remove the number seven main bearing, the removal of the bridge piece will be required. Follow Step 7.a through Step 7.b in order to remove the bridge piece.
- a. Remove allen head bolts (9) from bridge piece (10).
 - b. Remove bridge piece (10) from the cylinder block.

Installation Procedure

Table 68

Required Tools			
Tool	Part Number	Part Description	Qty
B	21825607	Degree Wheel	1
C	21825496	Indicator Bracket	1
	21825617	Dial Indicator	1
	-	Indicator Contact Point	1
	-	Universal Attachment	1
D	-	Loctite 5900 Sealant	1
E	-	Straight Edge	1

NOTICE

This procedure must only be used to remove and install the main bearing shells with the crankshaft in position.

The removal procedure and the installation procedure must be completed for each pair of main bearing shells before the next pair of main bearing shells are removed.

NOTICE

Keep all parts clean from contaminants.

Contaminants may cause rapid wear and shortened component life.

1. Ensure that the main bearing shells are clean and free from wear and damage. If necessary, replace the main bearing shells.

Note: If the main bearing shells are replaced, check whether oversize main bearing shells were previously installed. If the thrust washers are replaced, check whether oversize thrust washers were previously installed.

2. Clean the journals of the crankshaft. Inspect the journals of the crankshaft for damage. If necessary, replace the crankshaft or recondition the crankshaft.

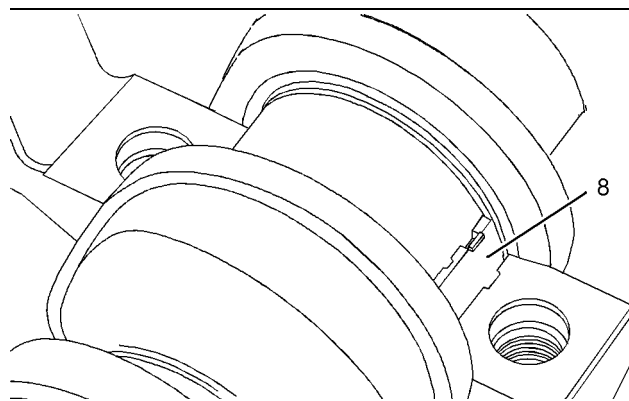

Illustration 237

g02204376

3. Lubricate the crankshaft journal and upper main bearing shell (8) with clean engine oil. Slide upper main bearing shell (8) into position between the crankshaft journal and the cylinder block. Ensure that the locating tab for the upper main bearing shell is correctly seated in the slot in the cylinder block.

Note: The upper main bearing shell has a groove and two oil holes.

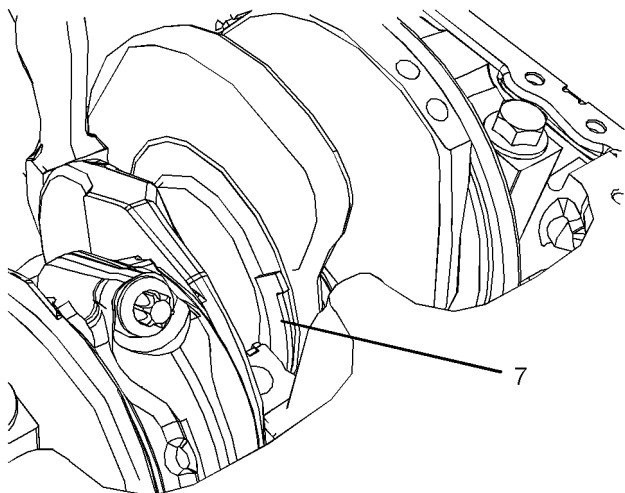

Illustration 238

g02711917

4. For number six main bearing, ensure that two thrust washers (7) are clean and free from wear and damage. If necessary, replace the thrust washers. Lubricate thrust washers (7) with clean engine oil. Slide thrust washers (7) into position between the crankshaft and the cylinder block. Ensure that the locating tab is correctly seated in the cylinder block.

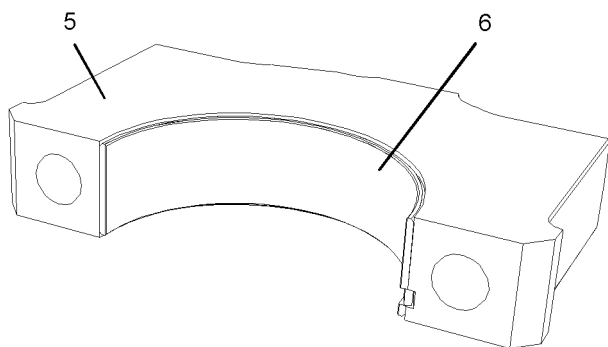

Illustration 239

g02204374

5. Install lower main bearing shell (6) into main bearing cap (5). Ensure that the locating tab for the lower main bearing shell is correctly seated into the slot in the bearing cap.

Note: The lower main bearing shell is a plain bearing that has no oil holes.

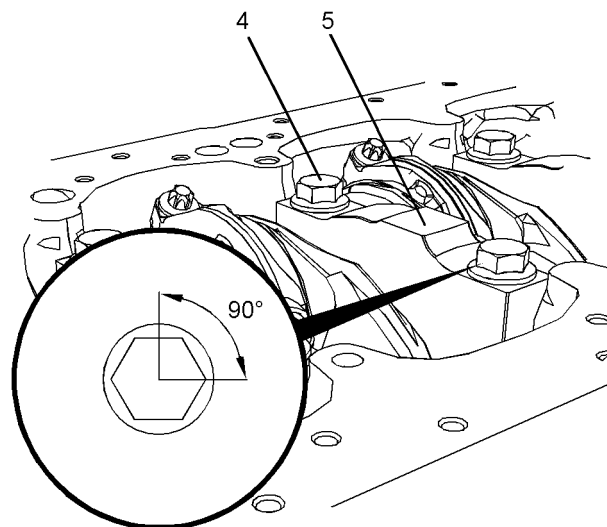

Illustration 240

g02204393

6. Lubricate the crankshaft journal and the lower main bearing shell with clean engine oil. Install main bearing cap (5) to the cylinder block.

Note: Ensure the correct orientation of the main bearing cap. The locating tab for the upper and the lower bearing should be on the same side of the engine.

7. Lubricate the threads of bolts (4) with clean engine oil. Lubricate the underside of the heads of bolts (4) with clean engine oil.

8. Install bolts (4) to main bearing cap (5). Evenly tighten the bolts in order to pull cap (5) into position. Ensure that the cap is correctly seated.

Note: Do not tap the main bearing cap into position as the bearing shell may be dislodged.

9. Tighten bolts (4) to a torque of 80 N·m (59 lb ft).

Turn bolts (4) through an additional 90 degrees. Use Tooling B to achieve the correct final torque.

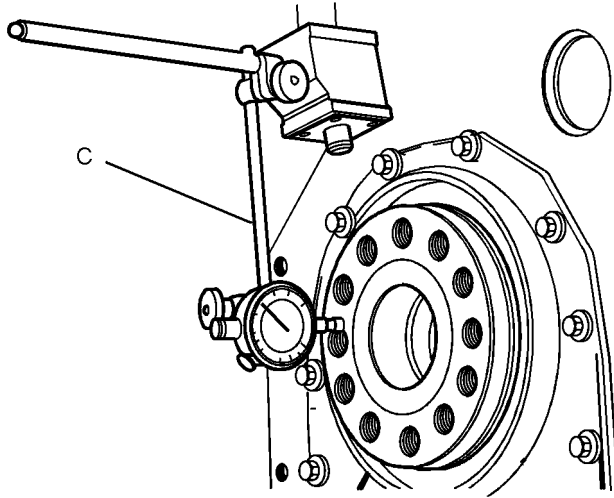

Illustration 241

g01341329

10. Check the crankshaft end play. Push the crankshaft toward the front of the engine. Install Tooling (C) to the cylinder block and the rear face of the crankshaft. Push the crankshaft toward the rear of the engine. Use Tooling (C) to measure the crankshaft end play. The permissible crankshaft end play is 0.10 mm (0.004 inch) to 0.41 mm (0.016 inch).

11. Remove Tooling (C) from the cylinder block.

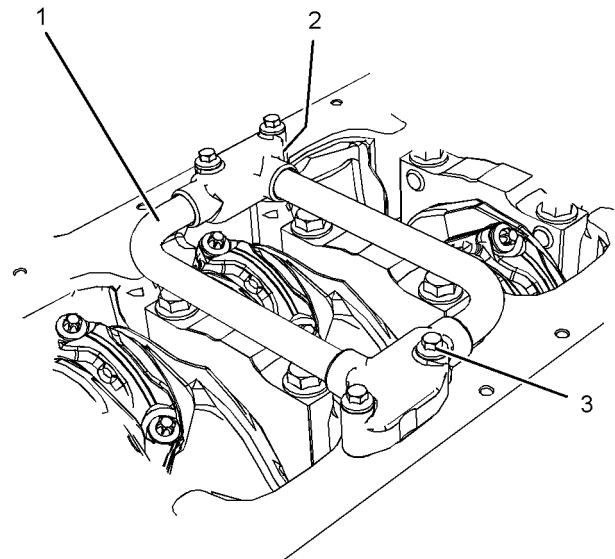

Illustration 242

g02724705

Typical example

12. If necessary, follow Step 12.a through Step 12.d in order to install the cross over tube assembly from the cylinder block.

- a. Position new gaskets (2) (not shown) onto the cylinder block.
- b. Position tube assembly (1) onto the cylinder block.
- c. Install bolts (3) to tube assembly (1).
- d. Tighten bolts (3) to a torque of 22 N·m (195 lb in).

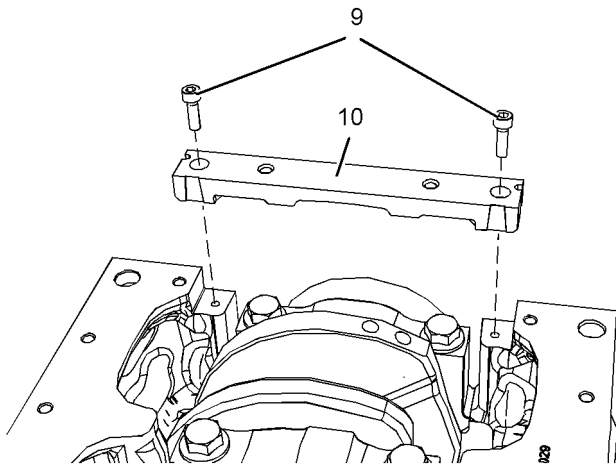

Illustration 243

g02724722

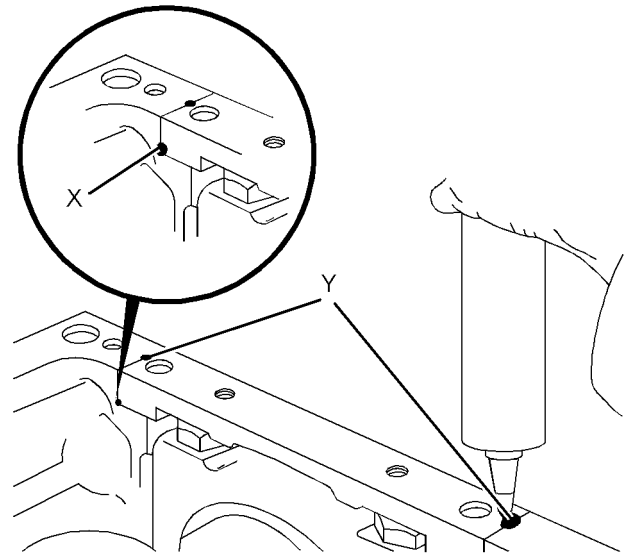

Illustration 245

g02725164

15. Apply Tooling (D) to Cavities (Y) in bridge piece (10). Continue to apply Tooling (D) until sealant extrudes from Cavities (X).

End By:

- a. Install the engine oil pump. Refer to Disassembly and Assembly, "Engine Oil Pump - Install" for the correct procedure.

i04472959

Crankshaft - Remove

Removal Procedure

Table 69

Required Tools			
Tool	Part Number	Part Description	Qty
A	-	Lifting Sling	2

Start By:

- a. Remove the engine oil pump. Refer to Disassembly and Assembly, "Engine Oil Pump - Remove" for the correct procedure.
- b. Remove the front housing. Refer to Disassembly and Assembly, "Housing (Front) - Remove" for the correct procedure.
- c. Remove the crankshaft rear seal. Refer to Disassembly and Assembly, "Crankshaft Rear Seal - Remove" for the correct procedure.

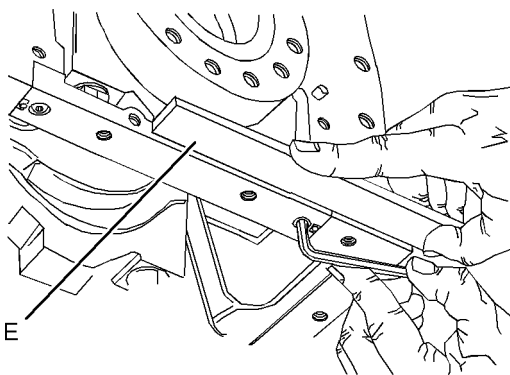

Illustration 244

g02725165

13. After number seven main bearing has been installed, the installation of the bridge piece will be required. Follow Step 13.a through Step 13.d in order to install the bridge piece.

- a. Ensure that the recess in the cylinder block and the bridge piece is clean, dry, and free from old sealant.
- b. Install bridge piece (10) and allen head bolts (9). Tighten the allen head bolts finger tight.
- c. Use Tooling (E) in order to align the rear face of bridge piece (10) with the rear face of the cylinder block.
- d. Tighten allen head bolts (9) to a torque of 16 N·m (142 lb in).

14. Install the crankshaft rear seal. Refer to Disassembly and Assembly, "Crankshaft Rear Seal - Install" for the correct procedure.

- d. If necessary, remove the cylinder head. Refer to Disassembly and Assembly, "Cylinder Head - Remove" for the correct procedure.
- e. If necessary, remove the pistons and connecting rods. Refer to Disassembly and Assembly, "Pistons and Connecting Rods - Remove" for the correct procedure.

NOTICE

Keep all parts clean from contaminants.

Contaminants may cause rapid wear and shortened component life.

1. The engine should be mounted on a suitable stand and placed in the inverted position.
2. If the cylinder head, the pistons and the connecting rods have not been removed already, remove the connecting rod bearings. Refer to Disassembly and Assembly, "Connecting Rod Bearings - Remove" for the correct procedure.
3. Ensure that the main bearing caps are marked for the location and orientation.

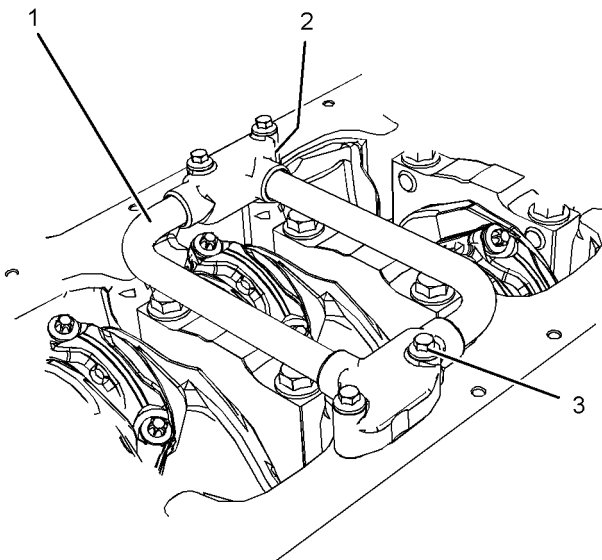

Illustration 246

g02724705

4. If necessary, follow Step 4.a through Step 4.c in order to remove the cross over tube assembly from the cylinder block.
 - a. Remove bolts (3) from tube assembly (1).

- b. Remove tube assembly (1) from the cylinder block.
- c. Remove gaskets (2) (not shown).

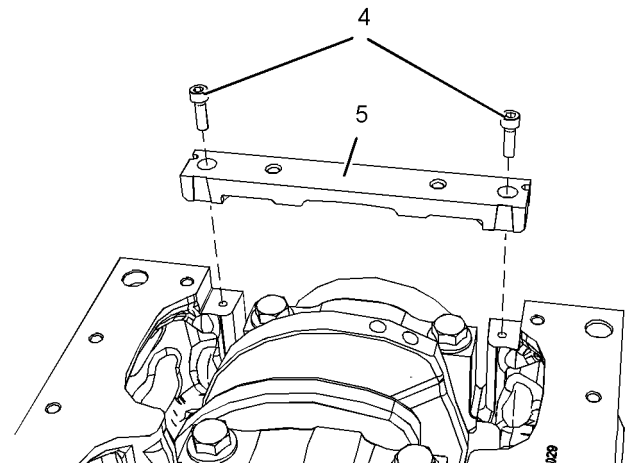

Illustration 247

g02725174

5. In order to remove the number seven main bearing, the removal of the bridge piece will be required. Follow Step 5.a through Step 5.b in order to remove the bridge piece.
 - a. Remove allen head bolts (4) from bridge piece (5).
 - b. Remove bridge piece (5) from the cylinder block.

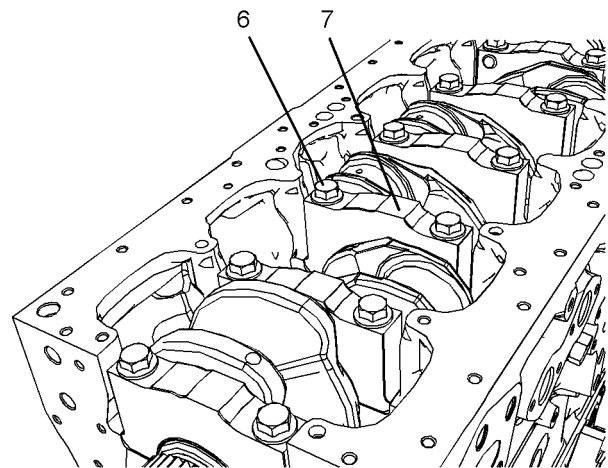

Illustration 248

g02725202

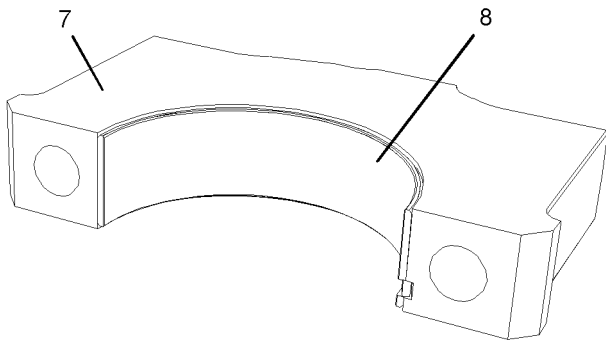

Illustration 249

g02725203

6. Remove bolts (6) and main bearing caps (7) from the cylinder block.
7. Remove lower main bearing shells (8) from main bearing caps (7). Keep the lower main bearing shells with the respective main bearing caps.

Note: The lower main bearing shells are plain bearings that have no oil holes.

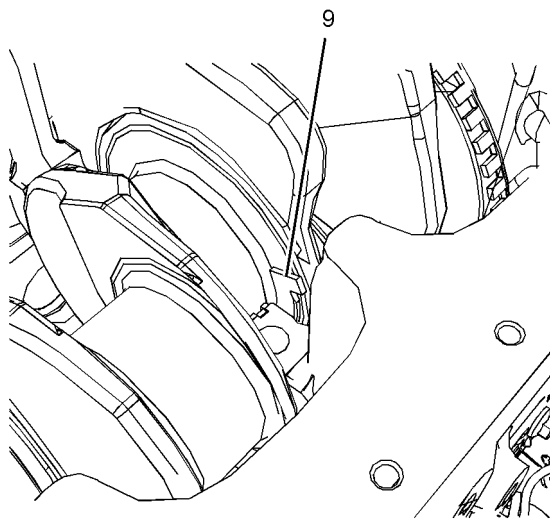

Illustration 250

g02725175

8. For number six main bearing, remove two thrust washers (9) from the cylinder block. In order to remove thrust washers (9), rotate the crankshaft in the correct direction. If necessary, push the crankshaft toward the front of the engine while you rotate the crankshaft, in order to aid removal. If necessary, push the crankshaft toward the rear of the engine while you rotate the crankshaft, in order to aid removal.

Note: The thrust washers have a locating tab at one end.

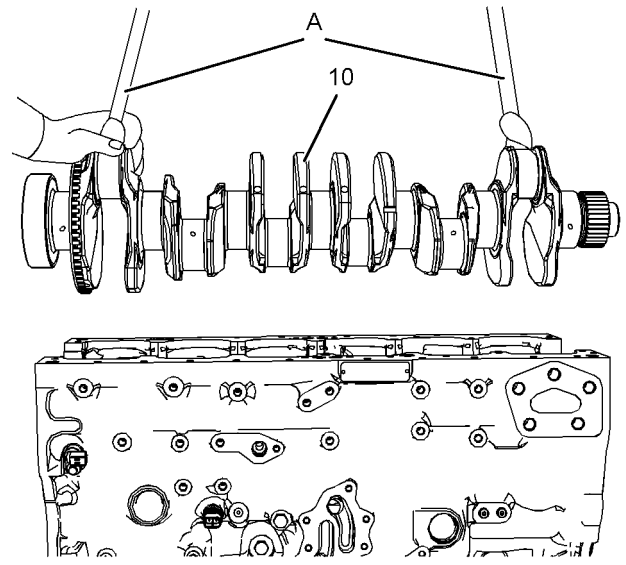

Illustration 251

g02725176

9. Attach Tooling (A) and a suitable lifting device to crankshaft (10). Lift crankshaft (10) out of the cylinder block. The weight of the crankshaft is approximately 61 kg (134 lb).

Note: Do not damage any of the finished surfaces on the crankshaft. When the crankshaft is removed from the engine, the crankshaft must be supported on a suitable stand in order to prevent damage to the crankshaft timing ring.

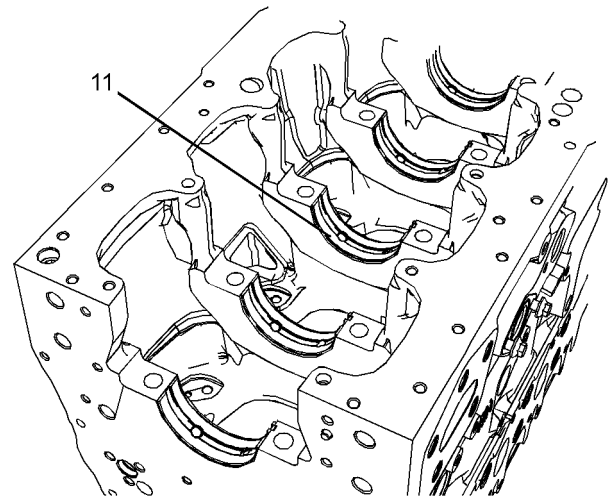

Illustration 252

g02725177

10. Remove upper main bearing shells (11) from the cylinder block. Keep the upper main bearing shells with the respective main bearing caps.

Note: The upper main bearing shells have a groove and two oil holes.

11. If necessary, remove the crankshaft gear. Refer to Disassembly and Assembly, "Crankshaft Gear - Remove and Install" for the correct procedure.

i04472958

Crankshaft - Install

Installation Procedure

Table 70

Required Tools			
Tool	Part Number	Part Description	Qty
A	-	Lifting Sling	2
B	21825607	Degree Wheel	1
C	21825496	Indicator Bracket	1
	21825617	Dial Indicator	1
	-	Indicator Contact Point	1
	-	Universal Attachment	1
D	-	Loctite 5900 Sealant	1
E	-	Straight Edge	1

NOTICE

Keep all parts clean from contaminants.

Contaminants may cause rapid wear and shortened component life.

1. Clean the crankshaft and inspect the crankshaft for wear and damage. Refer to Specifications, "Crankshaft" for more information. If necessary, replace the crankshaft or recondition the crankshaft.
2. If necessary, install the crankshaft gear. Refer to Disassembly and Assembly, "Crankshaft Gear - Remove and Install" for the correct procedure.
3. Ensure that parent bores for bearing shells in the cylinder block are clean. Ensure that the threads for the main bearing bolts in the cylinder block are clean and free from damage.
4. Clean the main bearing shells and the thrust washers. Inspect the main bearing shells and the thrust washers for wear and damage. If necessary, replace the main bearing shells and the thrust washers.

Note: If the main bearing shells are replaced, check whether oversize main bearing shells were previously installed. If the thrust washers are replaced, check whether oversize thrust washers were previously installed.

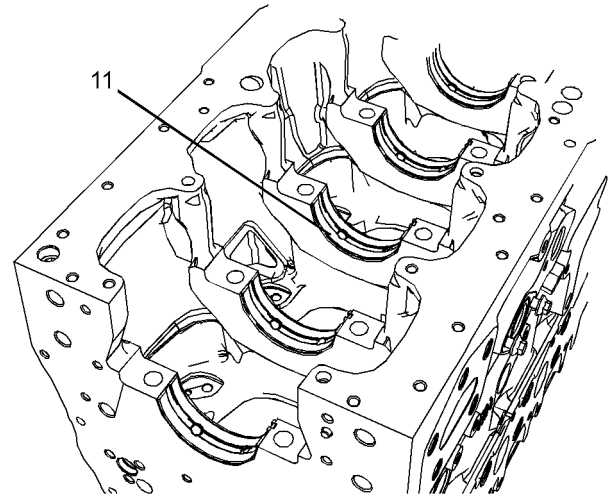

Illustration 253

g02725177

5. Install upper main bearing shells (11) to the cylinder block. Ensure that the locating tabs for the upper main bearing shells are seated in the slots in the cylinder block.

Note: The upper main bearing shells have a groove and two oil holes.

6. Lubricate upper main bearing shells (11) with clean engine oil.

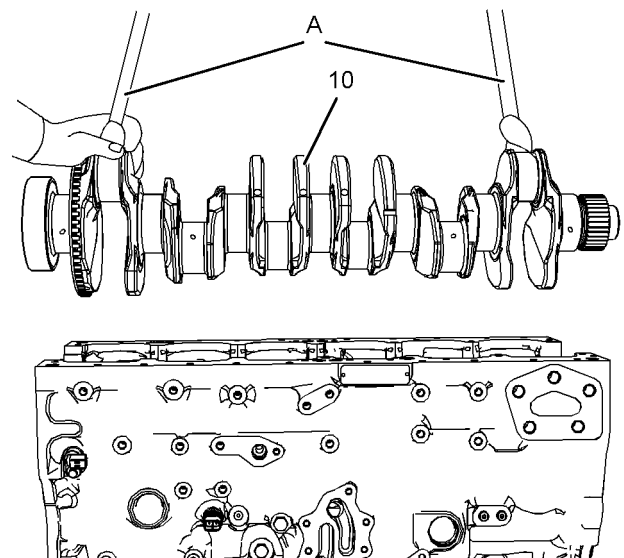

Illustration 254

g02725176

7. Attach Tooling (A) and a suitable lifting device to crankshaft (10). Lift crankshaft (10) into the cylinder block. The weight of the crankshaft is approximately 61 kg (134 lb).

Note: Do not damage any of the finished surfaces on the crankshaft. Do not damage the main bearing shells.

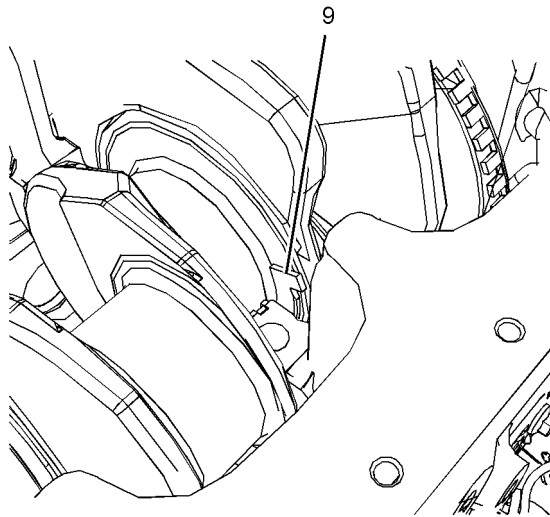

Illustration 255

g02725175

8. Lubricate thrust washers (9) with clean engine oil. Install thrust washers (9) into number six main bearing in the cylinder block.

Note: The grooves in the thrust washers must be located against the crankshaft. The thrust washers have a locating tab at one end. Ensure that the locating tabs are correctly seated in the cylinder block.

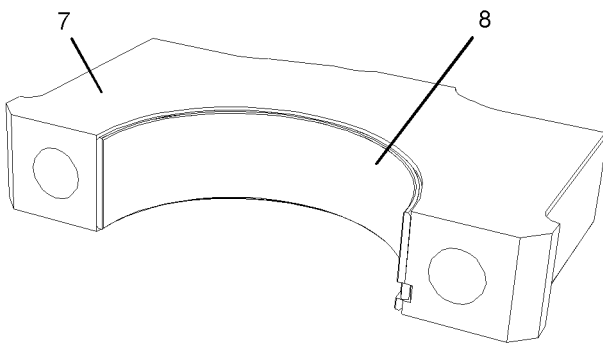

Illustration 256

g02725203

9. Install lower main bearing shells (8) into main bearing caps (7). Ensure that the locating tabs for the lower main bearing shells are correctly seated into the slots in the bearing caps.

Note: The lower main bearing shells are plain bearings that do not have oil holes.

10. Lubricate lower main bearing shells (8) and lubricate the journals of the crankshaft with clean engine oil. Install main bearing caps (7) to the cylinder block.

Note: Ensure the correct location and orientation of main bearing caps (7). The locating tabs for the upper and the lower main bearing shells should be on the same side of the engine.

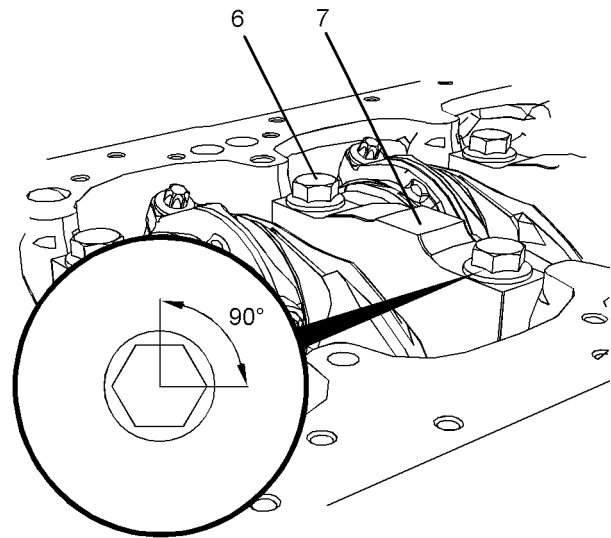

Illustration 257

g02725218

11. Lubricate the threads of bolts (6) with clean engine oil. Lubricate the underside of the heads of bolts (6) with clean engine oil.
12. Install bolts (6) to main bearing caps (7). Evenly tighten the bolts in order to pull the caps into position. Ensure that the caps are correctly seated.

Note: Do not tap the main bearing caps into position as the bearing shells may be dislodged.

13. Tighten bolts (6) to a torque of 80 N·m (59 lb ft).

Turn bolts (6) through an additional 90 degrees. Use Tooling (B) to achieve the final torque.

14. Rotate the crankshaft in order to ensure that there is no binding.

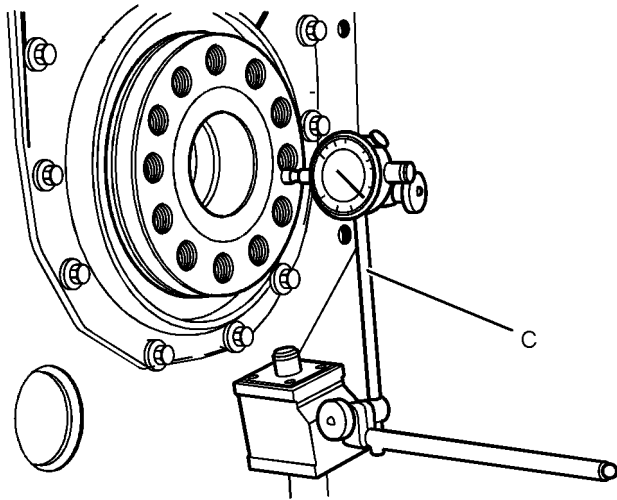

Illustration 258

g01399694

15. Check the crankshaft end play. Push the crankshaft toward the front of the engine. Install Tooling (C) to the cylinder block and the rear face of the crankshaft. Push the crankshaft toward the rear of the engine. Use Tooling (C) to measure the crankshaft end play. The permissible crankshaft end play is 0.10 mm (0.004 inch) to 0.41 mm (0.016 inch).

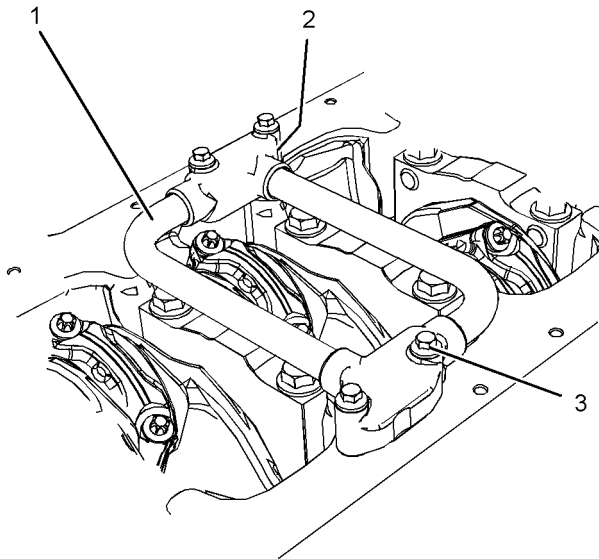

Illustration 259

g02724705

16. If necessary, follow Step 16.a through Step 16.c in order to install the cross over tube assembly from the cylinder block.

- a. Remove bolts (3) from tube assembly (1).
- b. Remove tube assembly (1) from the cylinder block.
- c. Remove gaskets (2) (not shown).

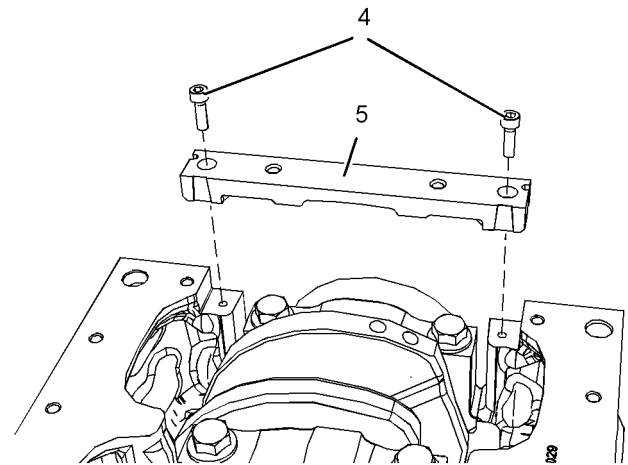

Illustration 260

g02725174

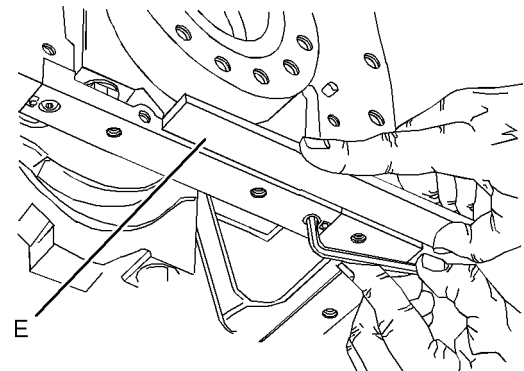

Illustration 261

g02725165

17. After number seven main bearing has been installed, the installation of the bridge piece will be required. Follow Step 17.a through Step 17.d in order to install the bridge piece.

- a. Ensure that the recess in the cylinder block and the bridge piece is clean, dry, and free from old sealant.
- b. Install bridge piece (10) and allen head bolts (9). Tighten the allen head bolts finger tight.

Note: Ensure that the bridge piece is correctly orientated.

- c. Use Tooling (E) in order to align the rear face of bridge piece (10) with the rear face of the cylinder block.
- d. Tighten allen head bolts (9) to a torque of 16 N·m (142 lb in).

18. Install the crankshaft rear seal. Refer to Disassembly and Assembly, "Crankshaft Rear Seal - Install" for the correct procedure.

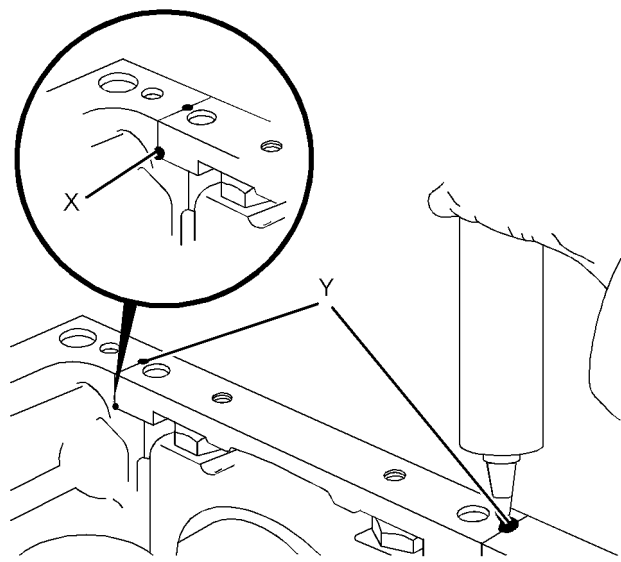

Illustration 262

g02725164

- 19. Apply Tooling (D) to Cavities (Y) in bridge piece (10). Continue to apply Tooling (D) until sealant extrudes from Cavities (X).
- 20. If the crankshaft has not been replaced or the crankshaft has not been reconditioned, install the connecting rod bearings. Refer to Disassembly and Assembly, "Connecting Rod Bearings - Install" for the correct procedure.

End By:

- a. If necessary, install the pistons and connecting rods. Refer to Disassembly and Assembly, "Pistons and Connecting Rods - Install" for the correct procedure.
- b. If necessary, install the cylinder head. Refer to Disassembly and Assembly, "Cylinder head - Install" for the correct procedure.
- c. Install the front housing. Refer to Disassembly and Assembly, "Housing (Front) - Install" for the correct procedure.
- d. Install the engine oil pump. Refer to Disassembly and Assembly, "Engine Oil Pump - Install" for the correct procedure.

i04472961

Crankshaft Gear - Remove and Install

Removal Procedure

Table 71

Required Tools			
Tool	Part Number	Part Description	Qty
A	-	Bearing Puller	1
	-	Screw	1
	-	Crossblock	1
	-	Puller Leg	2

Start By:

- a. Remove the front housing. Refer to Disassembly and Assembly, "Housing (Front) - Remove" for the correct procedure.
- b. Remove the engine oil pump. Refer to Disassembly and Assembly, "Engine Oil Pump - Remove" for the correct procedure.

NOTICE

Keep all parts clean from contaminants.

Contaminants may cause rapid wear and shortened component life.

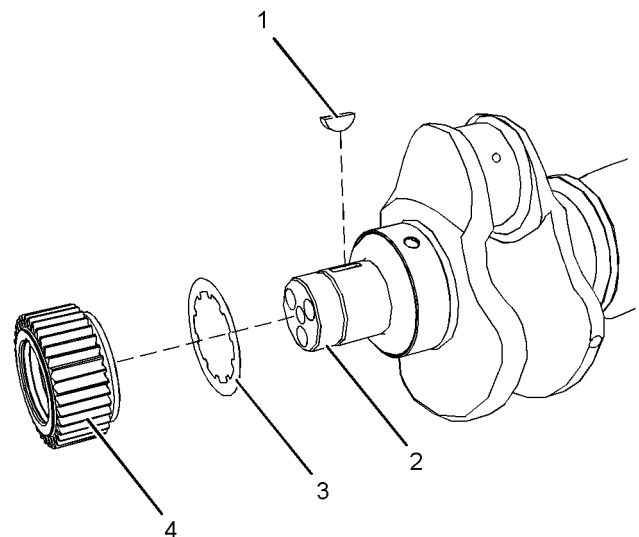

Illustration 263

g02048917

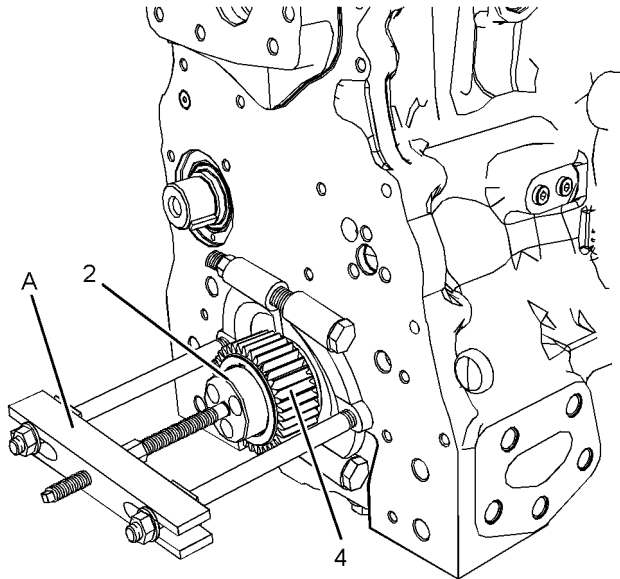

Illustration 264

g02049073

1. Use Tooling (A) in order to remove crankshaft gear (4) from crankshaft (2).
2. If necessary, remove key (1) and remove friction shim (3) from crankshaft (2).

Note: Do not remove the key from the crankshaft unless the key is damaged.

Installation Procedure

NOTICE

Keep all parts clean from contaminants.

Contaminants may cause rapid wear and shortened component life.

1. Ensure that all components are clean and free from wear and damage. If necessary, replace any components that are worn or damaged.

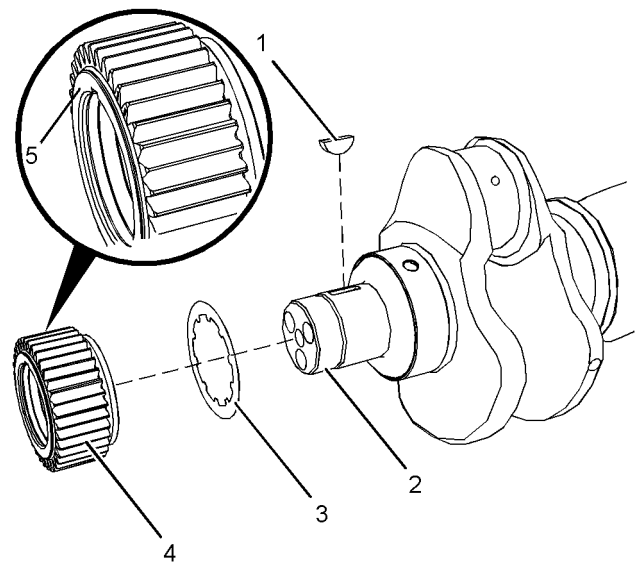

Illustration 265

g02052055

2. If necessary, install a new friction shim (3) to crankshaft (2).
3. If necessary, install a new key (1) to crankshaft (2).

WARNING

Hot parts or hot components can cause burns or personal injury. Do not allow hot parts or components to contact your skin. Use protective clothing or protective equipment to protect your skin.

4. Heat crankshaft gear (4) in an oven to $150^{\circ} \pm 50^{\circ}\text{C}$ ($302^{\circ} \pm 90^{\circ}\text{F}$). Align the keyway on crankshaft gear (4) with key (1) in the crankshaft. Install crankshaft gear (4) to crankshaft (2). Ensure that shoulder (5) of crankshaft gear (4) is toward the front of the engine.

End By:

- a. Install the front housing. Refer to Disassembly and Assembly, "Housing (Front) - Install" for the correct procedure.
- b. Install the engine oil pump. Refer to Disassembly and Assembly, "Engine Oil Pump - Install" for the correct procedure.

i02748526

Bearing Clearance - Check

Measurement Procedure

Table 72

Required Tools			
Tool	Part Number	Part Description	Qty
A	-	Plastic Gauge (Green) 0.025 to 0.076 mm (0.001 to 0.003 inch)	1
	-	Plastic Gauge (Red) 0.051 to 0.152 mm (0.002 to 0.006 inch)	1
	-	Plastic Gauge (Blue) 0.102 to 0.229 mm (0.004 to 0.009 inch)	1
	-	Plastic Gauge (Yellow) 0.230 to 0.510 mm (0.009 to 0.020 inch)	1

NOTICE

Keep all parts clean from contaminants.

Contaminants may cause rapid wear and shortened component life.

Note: Perkins does not recommend the checking of the actual clearances of the bearing shells particularly on small engines. This is because of the possibility of obtaining inaccurate results and of damaging the bearing shell or the journal surfaces. Each Perkins bearing shell is quality checked for specific wall thickness.

Note: The measurements should be within specifications and the correct bearings should be used. If the crankshaft journals and the bores for the block and the rods were measured during disassembly, no further checks are necessary. However, if the technician still wants to measure the bearing clearances, Tooling (A) is an acceptable method. Tooling (A) is less accurate on journals with small diameters if clearances are less than 0.10 mm (0.004 inch).

NOTICE

Lead wire, shim stock or a dial bore gauge can damage the bearing surfaces.

The technician must be very careful to use Tooling (A) correctly. The following points must be remembered:

- Ensure that the backs of the bearings and the bores are clean and dry.

- Ensure that the bearing locking tabs are properly seated in the tab grooves.
- The crankshaft must be free of oil at the contact points of Tooling (A).

1. Put a piece of Tooling (A) on the crown of the bearing that is in the cap.

Note: Do not allow Tooling (A) to extend over the edge of the bearing.

2. Use the correct torque-turn specifications in order to install the bearing cap. Do not use an impact wrench. Be careful not to dislodge the bearing when the cap is installed.

Note: Do not turn the crankshaft when Tooling (A) is installed.

3. Carefully remove the cap, but do not remove Tooling (A). Measure the width of Tooling (A) while Tooling (A) is in the bearing cap or on the crankshaft journal. Refer to Illustration 266.

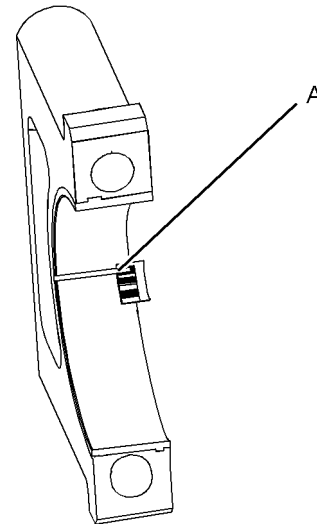

Illustration 266

g01152855

Typical Example

4. Remove all of Tooling (A) before you install the bearing cap.

Note: When Tooling (A) is used, the readings can sometimes be unclear. For example, all parts of Tooling (A) are not the same width. Measure the major width in order to ensure that the parts are within the specification range. Refer to Specifications Manual, "Connecting Rod Bearing Journal" and Specifications Manual, "Main Bearing Journal" for the correct clearances.

i04473052

Glow Plugs - Remove and Install

Removal Procedure

NOTICE

Keep all parts clean from contaminants.

Contaminants may cause rapid wear and shortened component life.

1. Turn the battery disconnect switch to the OFF position.

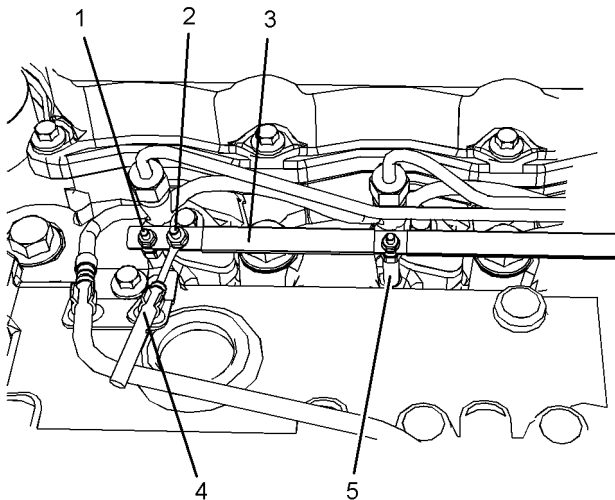

Illustration 267

g02708636

2. Remove nut (2) from busbar (3).
3. Disconnect harness assembly (4) from busbar (3) and the clip.
4. Remove nuts (1) that secure busbar (3) to glow plugs (5).
5. Remove busbar (1) from glow plugs (5).

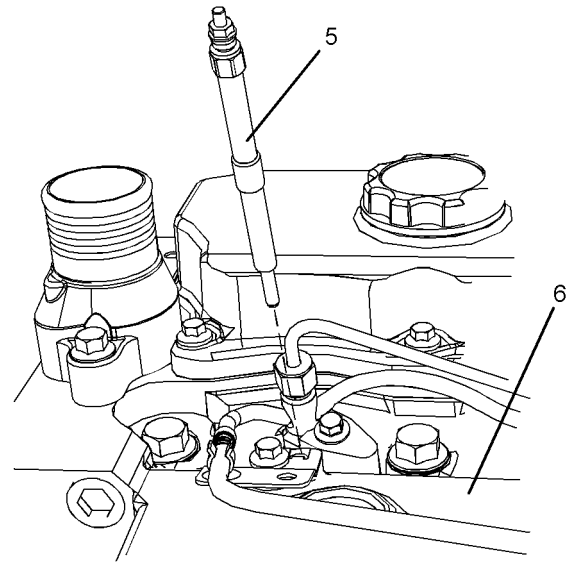

Illustration 268

g02708637

6. Clean the area around glow plugs (5). Ensure that the area is free from contamination before removal of the glow plugs.
7. Remove glow plugs (5) from cylinder head (6).

Installation Procedure

Table 73

Required Tools			
Tool	Part Number	Part Description	Qty
A	27610296	Torque Wrench	1

NOTICE

Keep all parts clean from contaminants.

Contaminants may cause rapid wear and shortened component life.

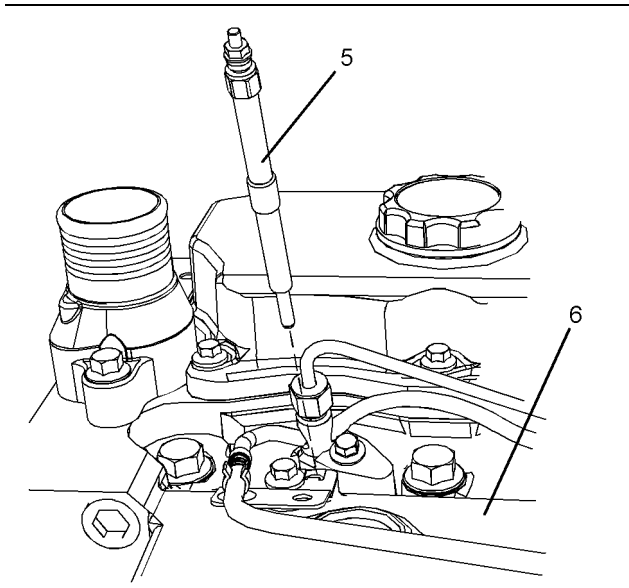

Illustration 269

g02708637

1. Before installing glow plugs (5), ensure that the glow plugs are operating correctly. Ref to Trouble Shooting, "Glow Plug Starting Aid - Test" "Check the Operation of the Glow Plugs" for the correct procedure.
2. Ensure that the threads of the glow plugs are clean and free from damage. Replace any damaged glow plugs.
3. Install glow plugs (5) into cylinder head (6). Tighten the glow plugs to a torque of 15 N·m (132 lb in).

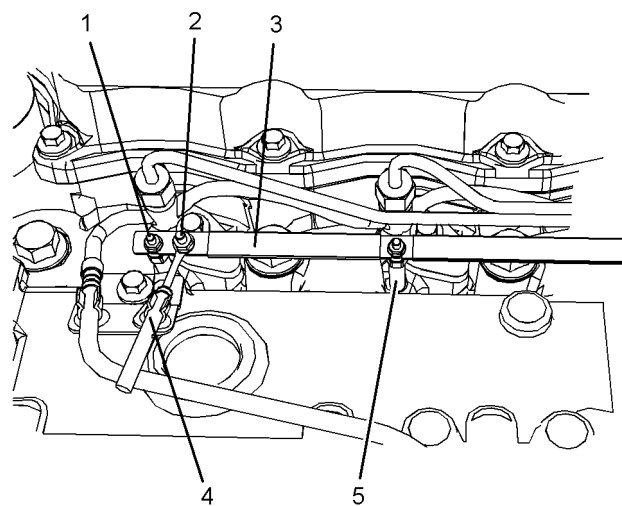

Illustration 270

g02708636

4. Position busbar (3) onto glow plugs (5). Tighten nuts (1) finger tight.

5. Use Tooling (A) to tighten nuts (1) to a torque of 2 N·m (17 lb in).
6. Connect harness assembly (4) to the stud on busbar (3) and the clip.
7. Install nut (2) to the stud on busbar (3). Tighten the nut to a torque of 6 N·m (53 lb in).
8. Turn the battery disconnect switch to the ON position.

End By:

- a. Install the inlet elbow and inlet air control (NRS Induction Mixer). Refer to Disassembly and Assembly, "Inlet Air Control (NRS Induction Mixer) - Install" for the correct procedure.

i04528076

V-Belts - Remove and Install

Removal Procedure

1. Turn the battery disconnect switch to the OFF position.

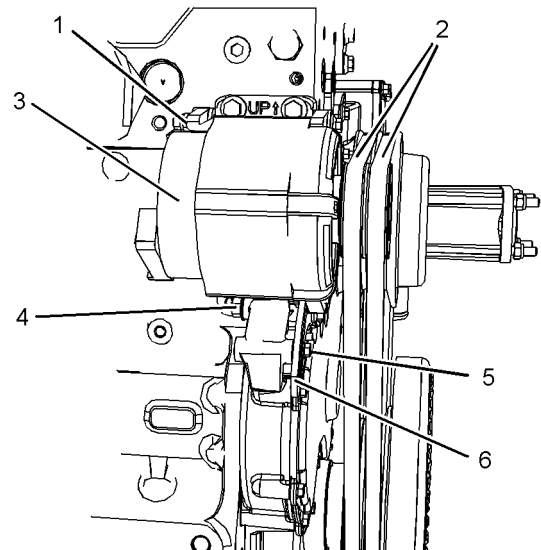

Illustration 271

g02710297

2. If the engine is equipped with fan guards, remove the fan guards.
3. Loosen nut and bolt (1).
4. Loosen the nut and bolt (4) for bracket (6).
5. Loosen bolt (5) for bracket (6).
6. Slide alternator (3) toward the engine.

- Remove V-belts (2) from the alternator (3) and the engine crankshaft pulley and the fan drive pulley.

Note: Mark the position and direction of rotation if the belts will be reused. Never replace single belts. Always replace belts as a pair.

Installation Procedure

Table 74

Required Tools			
Tool	Part Number	Part Description	Qty
A	-	Belt Tension Gauge	1

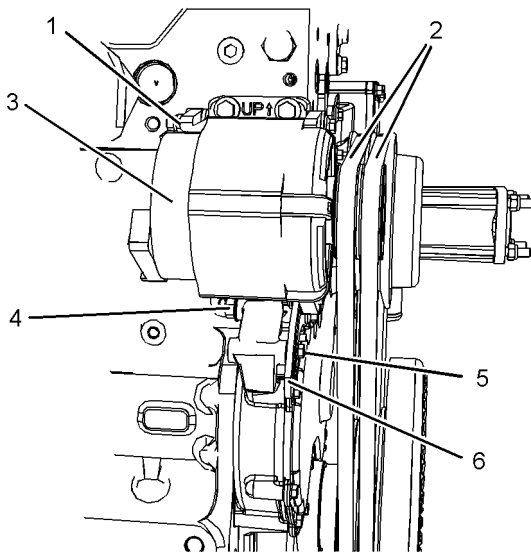

Illustration 272

g02710297

- Install belts (2) to alternator (3) and the engine crankshaft pulley and the fan drive pulley.

Note: Used V-belts should be installed in the original position and direction of rotation.

- Adjust the tension on the V-belts by moving the alternator away from the engine. Use Tooling (A) in order to achieve the correct belt tension. Refer to System Operation, Testing and Adjusting, "V-Belt -Test" for the correct procedure.
- Tighten bolt (5) for bracket (6) to a torque of 22 N·m (195 lb in).
- Tighten nut and bolt (4) to a torque of 44 N·m (32 lb ft).
- Tighten nut and bolt (1) to a torque of 22 N·m (195 lb in).
- If the engine is equipped with fan guards, install the fan guards.

- Turn the battery disconnect switch to the ON position.

i04472994

Fan - Remove and Install

Removal Procedure

Start By:

- Remove the V-belts. Refer to Disassembly and Assembly, "V-Belts - Remove and Install" for the correct procedure.

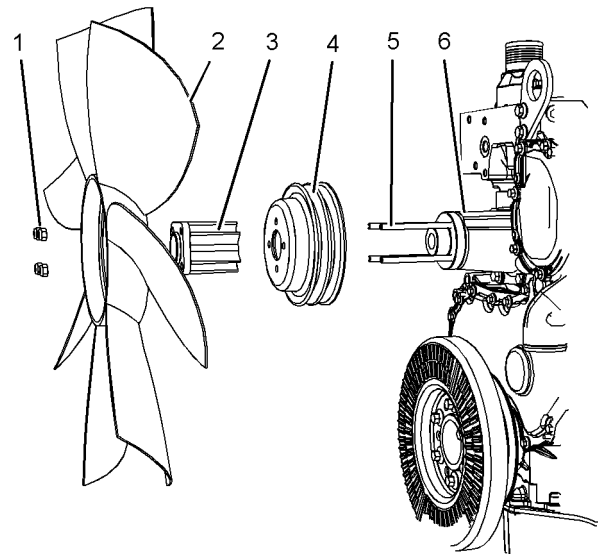

Illustration 273

g02701537

- Remove locking nuts (1).
 - Remove fan (2).
- Note:** Note the orientation of the fan.
- Remove fan adapter (3).
 - Remove fan pulley (4).
 - If necessary, remove studs (5) from fan drive (6).

Installation Procedure

- Ensure that all the components are free from wear and damage. If necessary, replace any components that are worn or damaged.

i04472995

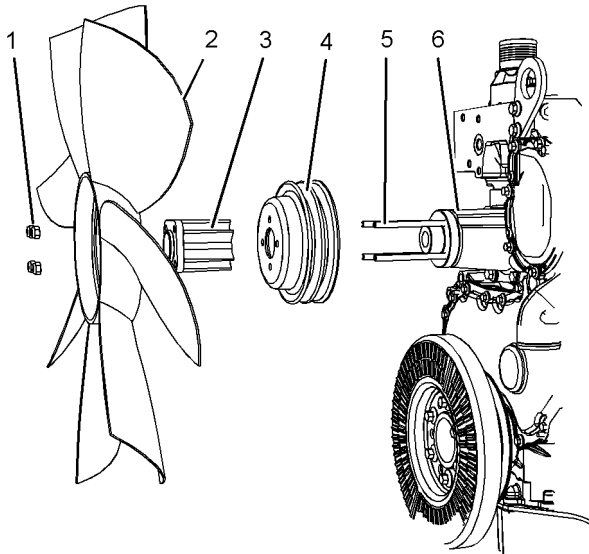

Illustration 274

g02701537

2. If necessary, install studs (5) to fan drive (6). Tighten studs (5) to a torque of 11 N·m (97 lb in).
 3. If studs (5) have not been previously removed from fan drive (6). It will be necessary to check for the correct installation of the studs to the fan drive. Tighten studs (5) to a torque of 11 N·m (97 lb in).
 4. Install fan pulley (4).
 5. Install fan adapter (3).
 6. Install fan (2).
- Note:** Ensure that the fan is correctly oriented.
7. Inspect the condition of locking nuts (1). If necessary, replace the locking nuts. Install locking nuts (1). Tighten locking nuts (1) to a torque of 22 N·m (195 lb in).

End By:

- a. Install the V-Belts. Refer to Disassembly and Assembly, "V-Belts - Remove and Install" for the correct procedure.

Fan Drive - Remove and Install

Removal Procedure

Start By:

- a. Remove the fan. Refer to Disassembly and Assembly, "Fan - Remove and Install" for the correct procedure.

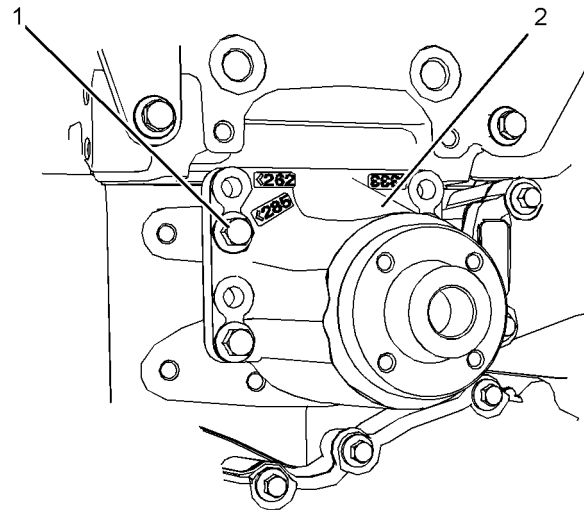

Illustration 275

g02701544

1. Make a temporary mark on fan drive assembly (2) in order to identify the orientation and the position.
2. Remove bolts (1) from fan drive assembly (2).
3. Remove fan drive assembly (2).

Installation Procedure

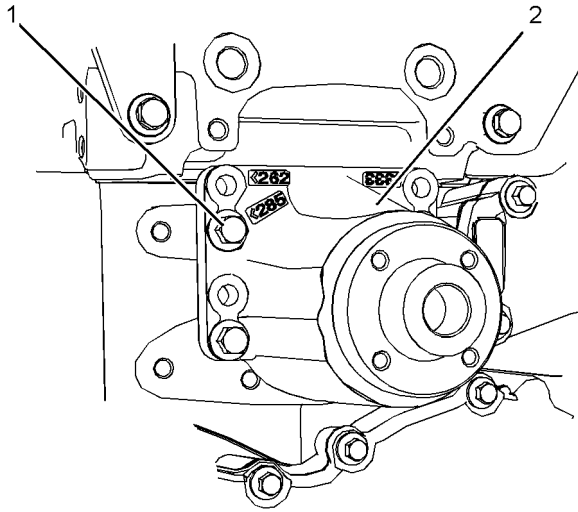

Illustration 276

g02701544

1. Check the fan drive for wear and damage. If the fan drive is worn or damaged, replace the fan drive.
 2. Install fan drive assembly (2).
- Note:** Ensure that the fan drive is correctly oriented.
3. Install bolts (1) finger tight to fan drive assembly (2). Tighten the bolts to a torque of 44 N·m (32 lb ft).

End By:

- a. Install the fan. Refer to Disassembly and Assembly, "Fan - Remove and Install" for the correct procedure.

i04472930

Alternator - Remove

Removal Procedure

Start By:

- a. Remove the V-belts. Refer to Disassembly and Assembly, "V-belts - Remove and Install".

NOTICE

Keep all parts clean from contaminants.

Contaminants may cause rapid wear and shortened component life.

1. Turn the battery disconnect switch to the OFF position.

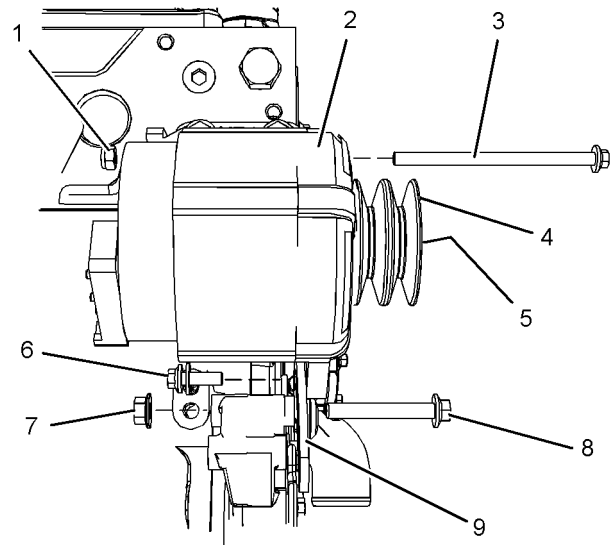

Illustration 277

g02711217

2. Make temporary identification marks on the connections of the harness assembly. Disconnect the harness assembly from alternator (2).
 3. Remove bolt and washer (6) from alternator (4).
 4. Remove nut (7) and remove bolt (8) from bracket (9).
 5. Remove bracket (9).
 6. Remove nut (1) and remove bolt (3) from alternator (2).
- Note:** Support the alternator as the bolt is removed.
7. Remove alternator (2) from the bracket for the alternator.
 8. If necessary, follow Step 8.a through Step 8.b in order to remove the pulley from the alternator.

Note: This method may not be suitable for some configurations of pulley.

- a. Hold the shaft of alternator (2) with an allen wrench. Use a cranked ring spanner in order to loosen nut (5) (not shown).
- b. Remove nut (5) (not shown) and pulley (4) from alternator (2).

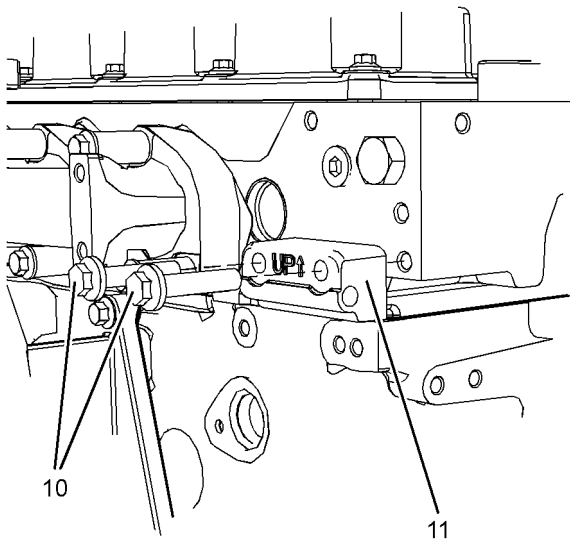

Illustration 278

g02711220

9. If necessary, follow Step 9.a through Step 9.b in order to remove the bracket for the alternator from the cylinder head.

- a. Remove bolts (10) from bracket (11).
- b. Remove bracket (11) from the cylinder head.

Note: Note the orientation of the bracket.

i04472929

Alternator - Install

Installation Procedure

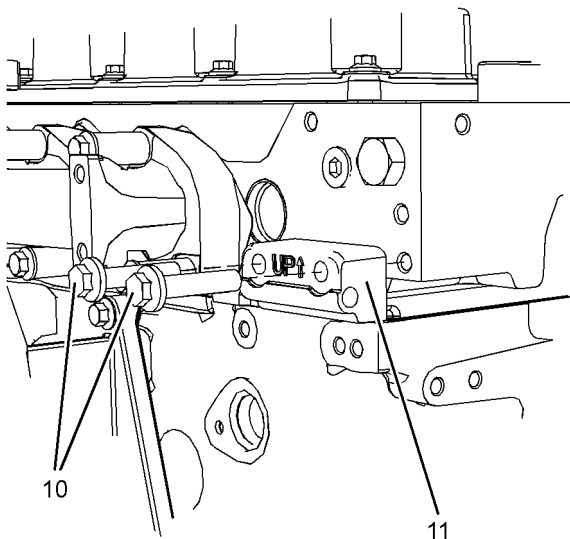

Illustration 279

g02711220

1. If necessary, follow Step 1.a through Step 1.c in order to install the bracket for the alternator to the cylinder head.

- a. Position bracket (11) onto the cylinder head with the arrow and the word UP in the vertical position.
- b. Install bolts (10) to bracket (11) finger tight.
- c. Tighten bolts (10) to a torque of 44 N·m (32 lb ft).

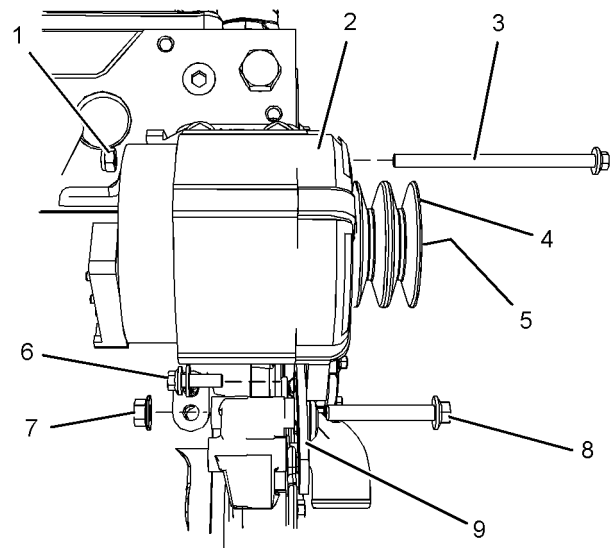

Illustration 280

g02711217

2. If necessary, follow Step 2.a through Step 2.b in order to install the pulley to the alternator.

Note: This method may not be suitable for some configurations of pulley.

- a. Install pulley (4) and nut (5) (not shown) to the shaft of alternator (2).
- b. Hold the shaft of the alternator with an allen wrench. Use a cranked ring spanner in order to tighten nut (5) (not shown). Tighten the nut to a torque of 80 N·m (59 lb ft).
- 3. Install alternator (2) to the bracket for the alternator. Install bolt (3) to alternator (2).
- 4. Install nut (1) to bolt (3) finger tight.
- 5. Install bracket (9) and install bolt and washer (6) to alternator (2) finger tight.
- 6. Install bolt (8) and nut (7) finger tight.
- 7. Install the V-belts. Refer to the Disassembly and Assembly, "V-belts - Remove and Install" for the correct procedure.

8. Tighten nut (1) and bolt (3) to a torque of 22 N·m (195 lb in).
9. Tighten bolt and washer (6) to a torque of 22 N·m (195 lb in).
10. Tighten nut (7) and bolt (8) to a torque of 44 N·m (32 lb ft).
11. Connect the harness assembly to alternator (2).
12. Turn the battery disconnect switch to the ON position.

i04472967

Electric Starting Motor - Remove and Install

Removal Procedure

WARNING

Accidental engine starting can cause injury or death to personnel working on the equipment.

To avoid accidental engine starting, disconnect the battery cable from the negative (-) battery terminal. Completely tape all metal surfaces of the disconnected battery cable end in order to prevent contact with other metal surfaces which could activate the engine electrical system.

Place a Do Not Operate tag at the Start/Stop switch location to inform personnel that the equipment is being worked on.

1. Turn the battery disconnect switch to the OFF position.
2. Place identification marks on the harness assembly that is connected to the electric starting motor and the solenoid.

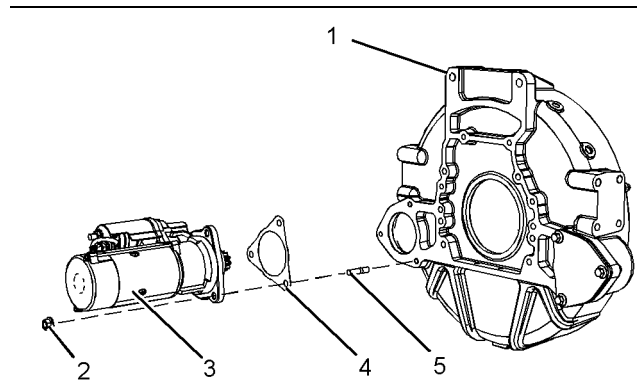

Illustration 281

Typical example

g01973073

3. Disconnect the harness assembly from the electric starting motor and the solenoid.
4. Support electric starting motor (3).
5. Remove nuts or bolts (2).
6. Remove electric starting motor (3).
7. If a gasket is installed, remove gasket (4).
8. If necessary, remove studs (5) from flywheel housing (1).

Installation Procedure

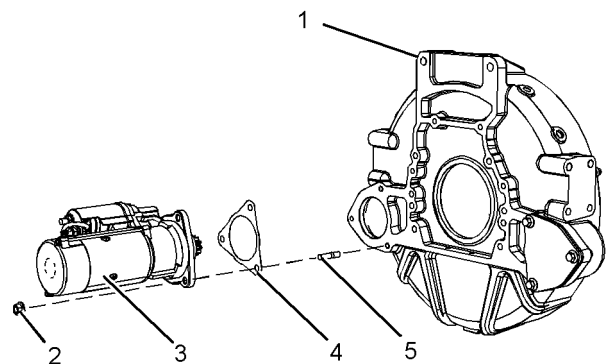

Illustration 282

Typical example

g01973073

1. If necessary, install studs (5) into flywheel housing (1).

Tighten M10 studs to a torque of 18 N·m (159 lb in).

Tighten M12 studs to a torque of 25 N·m (221 lb in).
2. If necessary, install a new gasket (4) onto the studs in flywheel housing (1).

3. Position electric starting motor (3) onto the studs in flywheel housing (1).
4. Install nuts or bolts (2).

Tighten M10 nuts to a torque of 44 N·m (33 lb ft).

Tighten M12 nuts to a torque of 78 N·m (58 lb ft).
5. Connect the harness assembly to the electric starting motor and the solenoid.
6. Turn the battery disconnect switch to the ON position.

i04528054

Air Compressor - Remove and Install

Removal Procedure

Table 75

Required Tools			
Tool	Part Number	Part Description	Qty
A ⁽¹⁾	T400011	Crankshaft Turning Tool	1
A ⁽²⁾	27610291	Housing	1
	27610289	Gear	1
B	27610286	Timing Pin (Crankshaft)	1
C	-	Combination Puller	1

⁽¹⁾ The Crankshaft Turning Tool is used on the front pulley.

⁽²⁾ This Tool is used in the aperture for the electric starting motor.

Note: Either Tooling (A) can be used. Use the Tooling that is most suitable.

NOTICE

Care must be taken to ensure that fluids are contained during performance of inspection, maintenance, testing, adjusting and repair of the product. Be prepared to collect the fluid with suitable containers before opening any compartment or disassembling any component containing fluids.

Dispose of all fluids according to local regulations and mandates.

NOTICE

Keep all parts clean from contaminants.

Contaminants may cause rapid wear and shortened component life.

Note: Put identification marks on all hoses, on all hose assemblies and on all tube assemblies for installation purposes. Plug all hose assemblies and tube assemblies. Plugging hose assemblies helps to prevent fluid loss. Plugging hose assemblies helps to keep contaminants from entering the system.

WARNING

Do not disconnect the air lines until the air pressure in the system is at zero. If hose is disconnected under pressure it can cause personal injury.

1. Release the pressure from the air system. Refer to the Original Equipment Manufactures (OEM) for the correct procedure.
2. Drain the coolant from the cooling system into a suitable container for storage or for disposal. Refer to Operation and Maintenance Manual, "Cooling System Coolant - Change" for the correct draining procedure.
3. If the engine is equipped with a hydraulic pump on the rear of the air compressor, remove the hydraulic pump. Refer to the (OEM for the correct procedure.

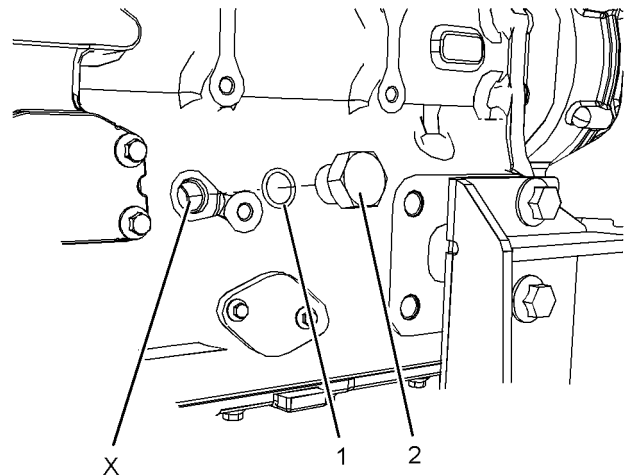

Illustration 283

g02710999

Typical example

4. Remove plug (2) from the cylinder block. Remove O-ring seal (1) from plug (2).
5. Use Tooling (A) in order to rotate the crankshaft so that number one piston is at top dead center on the compression stroke. Refer to System Operation, Testing and Adjusting, "Finding Top Center Position for No.1 Piston" for the correct procedure.

Note: The air compressor must be timed with the engine in order to minimize engine vibration.

6. Install Tooling (B) into Hole (X) in the cylinder block. Use Tooling (B) in order to lock the crankshaft in the correct position.

Note: Do not use excessive force to install Tooling (B). Do not use Tooling (B) to hold the crankshaft during repairs.

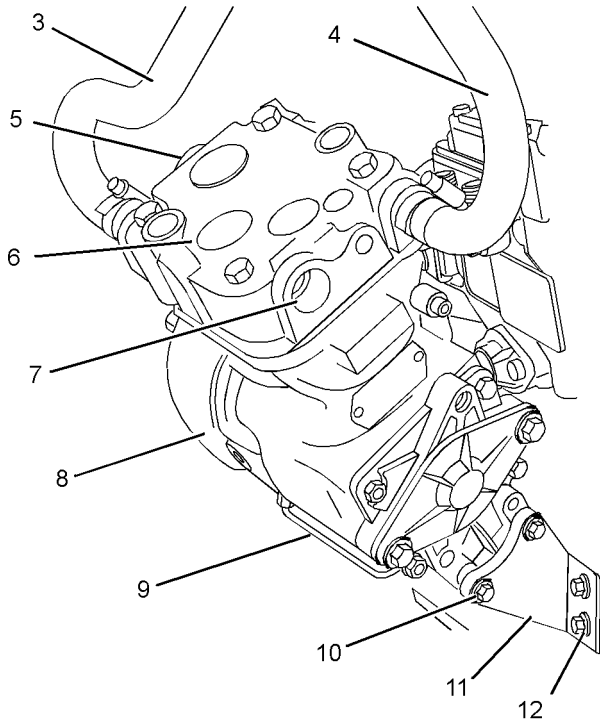

Illustration 284
Typical example

g02711018

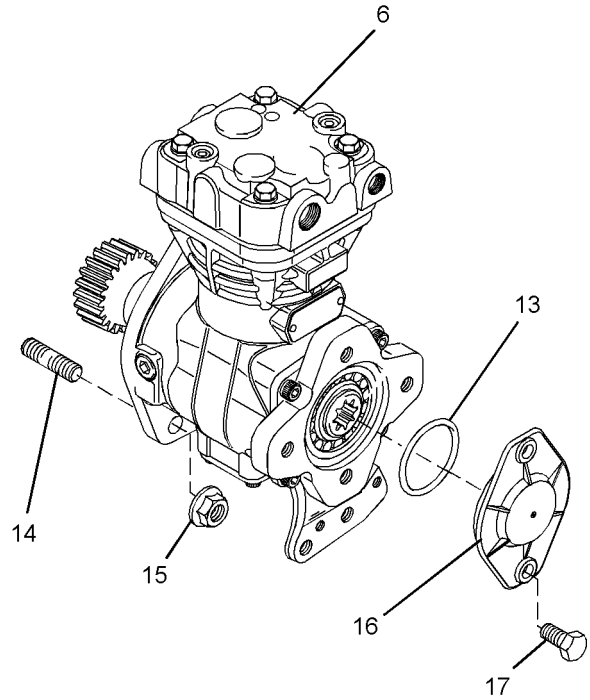

Illustration 285
Typical example

g02711019

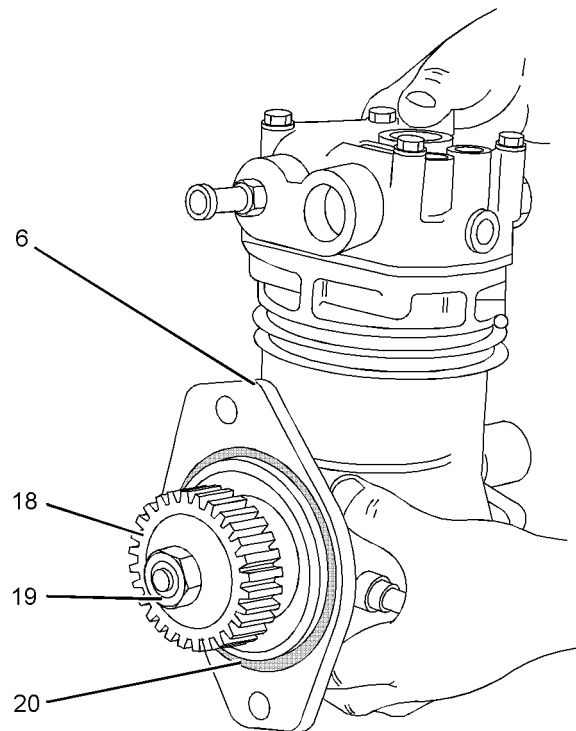

Illustration 286
Typical example

g02711020

7. Disconnect coolant hose (3) and hose (4) from air compressor (6).

8. Disconnect the air lines from port (5) and port (7). Refer to the OEM for the correct procedure.
9. Remove tube assembly (9) from air compressor (6) and from the cylinder block.
10. Remove bolt (10) and bolt (12) from support bracket (11) and remove the support bracket.
11. Support air compressor (6). Remove nuts (15) and remove the air compressor from front housing (8).
12. Remove O-ring seal (20) from air compressor (6).
13. If necessary, remove bolts (17) and remove plate (16). Remove O-ring seal (13) from plate (16). Refer to Illustration 285.
14. If necessary, follow Step 14.a through Step 14.b in order to remove the gear from the compressor.
 - a. Remove nut (19) and remove the spring washer.
 - b. Use Tooling (C) in order to remove gear (18) from the crankshaft of air compressor (6).

Installation Procedure

Table 76

Required Tools			
Tool	Part Number	Part Description	Qty
A ⁽¹⁾	T400011	Crankshaft Turning Tool	1
A ⁽²⁾	27610291	Housing	1
	27610289	Gear	1
B	27610286	Timing Pin (Crankshaft)	1
D	-	Loctite 638 High Strength Retaining	1
E	-	Delphi Lockheed Rubber Grease	1

⁽¹⁾ The Crankshaft Turning Tool is used on the front pulley.

⁽²⁾ This Tool is used in the aperture for the electric starting motor.

NOTICE

Keep all parts clean from contaminants.

Contaminants may cause rapid wear and shortened component life.

NOTICE

Care must be taken to ensure that fluids are contained during performance of inspection, maintenance, testing, adjusting and repair of the product. Be prepared to collect the fluid with suitable containers before opening any compartment or disassembling any component containing fluids.

Dispose of all fluids according to local regulations and mandates.

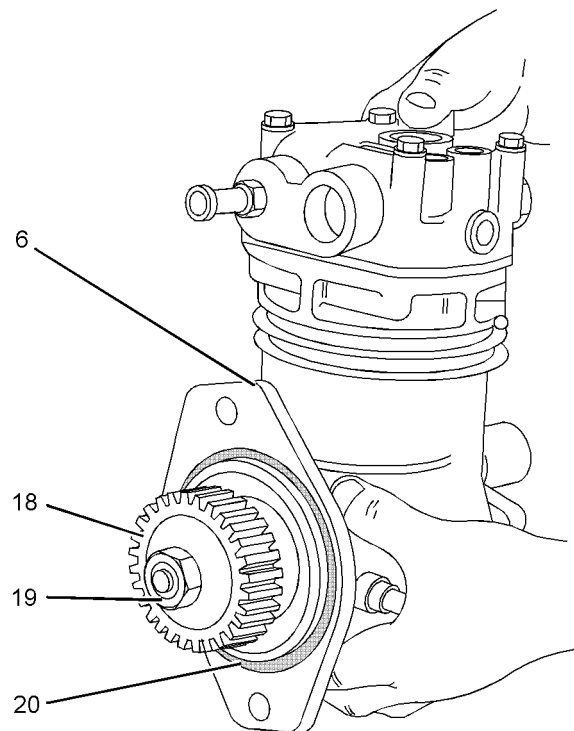

Illustration 287

g02711020

Typical example

1. If necessary, follow Steps 1.a through 1.b in order to install the gear to the air compressor.
 - a. Ensure that the shaft of air compressor (6) is clean and dry. Ensure that gear (18) is clean and free from damage.
 - b. Install gear (18) and a new spring washer to the shaft of the air compressor.
 - c. Apply Tooling (D) to the threads of the shaft. Install nut (19) to the shaft of air compressor (6). Tighten the nut to a torque of 120 N·m (89 lb ft).
2. Install O-ring seal (20) to air compressor (6). Use Tooling (E) in order to lubricate the O-ring seal.

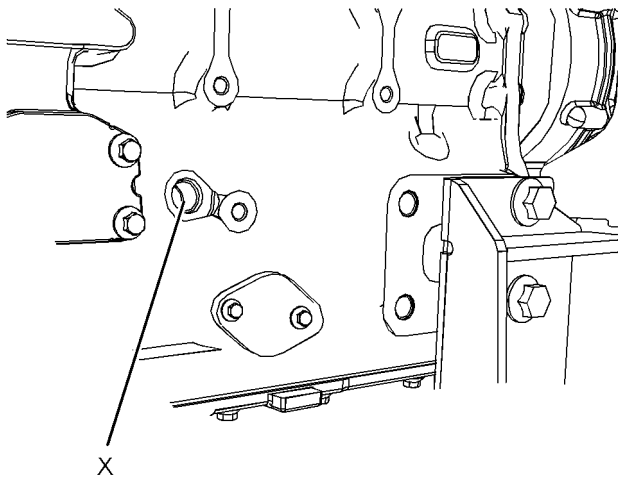

Illustration 288 g02711036
Typical example

3. If necessary, use Tooling (A) to ensure that number one piston is at the top center position on the compression stroke. Refer to the Systems Operation, Testing and Adjusting, "Finding Top Center Position for No. 1 Piston".

Note: The air compressor must be timed with the engine in order to minimize engine vibration.

4. Ensure that Tooling (B) is installed in Hole (X) in the cylinder block. Use Tooling (B) in order to lock the crankshaft in the correct position.

Note: Do not use excessive force to install Tooling (B). Do not use Tooling (B) to hold the crankshaft during repairs.

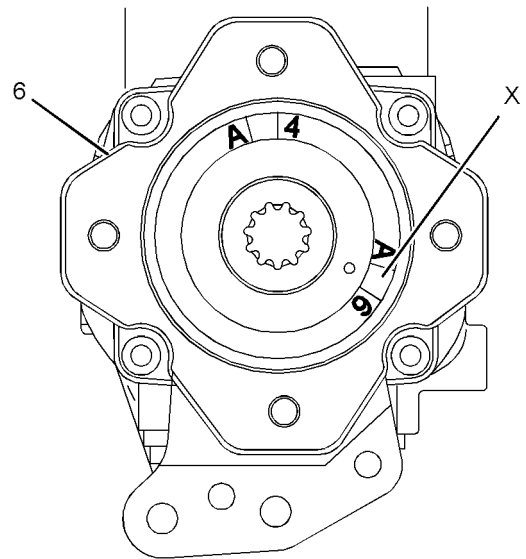

Illustration 289 g02711021
Typical air compressor with a SAE drive

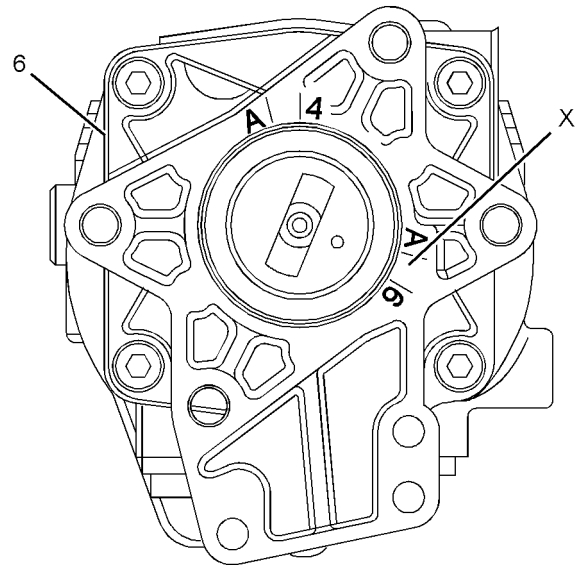

Illustration 290 g02711022
Typical air compressor with a DIN drive

5. Rotate the crankshaft of the air compressor until timing Mark (X) is aligned with timing mark A6 on the rear face of air compressor (6). Refer to Illustration 289 for air compressors with a SAE drive. Refer to Illustration 290 for air compressors with a DIN drive.

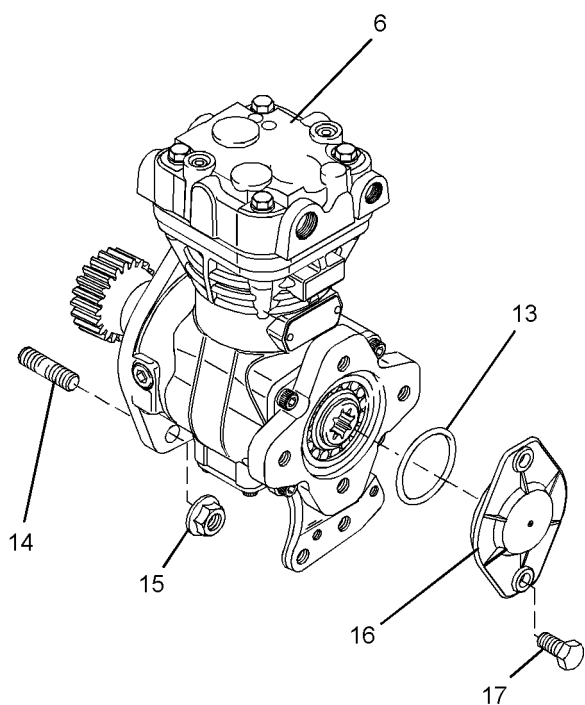

Illustration 291

g02711019

Typical example

6. Align air compressor (6) with studs (14). Install the air compressor to the front housing. If necessary, rotate the crankshaft of the air compressor in a clockwise direction in order to align the gears.

Note: Ensure that timing Mark (X) is aligned with the timing mark A6. Refer to Illustration 289 for air compressors with a SAE drive. Refer to Illustration 290 for air compressors with a DIN drive.

7. Install nuts (15). Tighten the nuts to a torque of 78 N·m (58 lb ft).

8. If necessary, follow Steps 8.a through 8.c in order to install cover (15).

a. Install a new O-ring seal (13) to cover (16). Use Tooling (E) in order to lubricate the O-ring seal.

b. Install cover (16) to air compressor (6).

c. Install bolts (17). Tighten the bolts to a torque of 13 N·m (115 lb in).

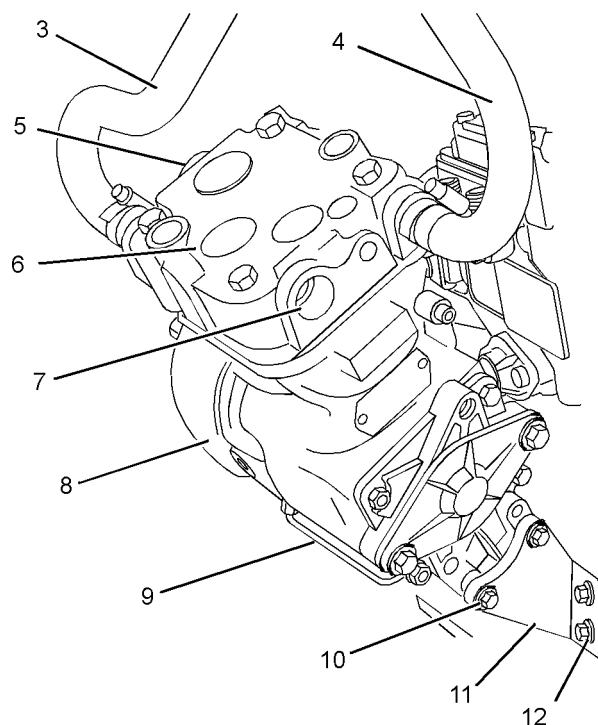

Illustration 292

g02711018

Typical example

9. Position support bracket (11) onto air compressor (6). Install bolts (10) finger tight.

10. Install bolts (12) finger tight.

11. Tighten bolts (10) to a torque of 22 N·m (195 lb in). Tighten bolts (12) to a torque 44 N·m (32 lb ft).

Note: Ensure that the air compressor is not stressed as the bolts are tightened.

12. Install tube assembly (9) to air compressor (6) and to the cylinder block. Tighten the nuts for tube assembly (9) to a torque of 9 N·m (80 lb in).

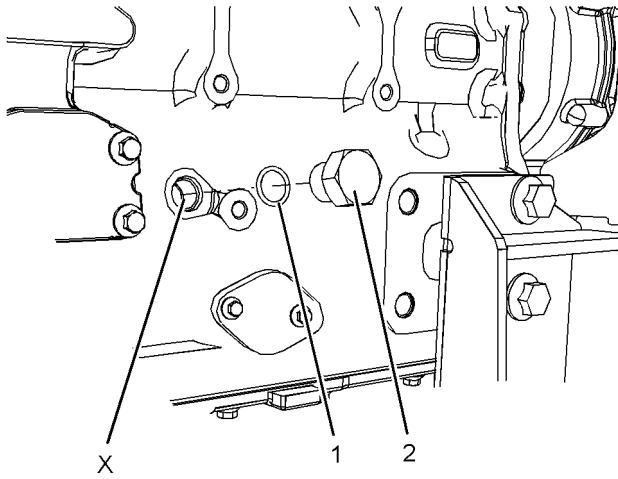

Illustration 293

g02710999

Typical example

- 13.** Remove Tooling (B) from Hole (X) in the cylinder block. Install a new O-ring seal (1) to plug (2). Install plug (2) to the cylinder block. Tighten the plug to a torque of 21 N·m (186 lb in)
- 14.** If the engine is equipped with a hydraulic pump on the rear of the air compressor, install the hydraulic pump. Refer to the OEM for the correct procedure.
- 15.** Connect the air lines to port (5) and port (7) in the air compressor. Refer to the OEM for the correct procedure.
- 16.** Connect coolant hose (2) and hose (3) to air compressor (5).
- 17.** Fill the cooling system with coolant to the correct level. Refer to Operation and Maintenance Manual, "Cooling System Coolant - Change" for the correct filling procedure.

Index

A

Accessory Drive - Remove and Install (Accessory Drive SAE "A").....	80
Installation Procedure	81
Removal Procedure	80
Air Compressor - Remove and Install.....	142
Installation Procedure	144
Removal Procedure	142
Alternator - Install	140
Installation Procedure	140
Alternator - Remove	139
Removal Procedure	139

B

Bearing Clearance - Check	134
Measurement Procedure	134

C

Camshaft - Remove and Install	96
Installation Procedure	97
Removal Procedure	96
Camshaft Bearings - Remove and Install	103
Installation Procedure	103
Removal Procedure	103
Camshaft Gear - Remove and Install	99
Installation Procedure	101
Removal Procedure	99
Connecting Rod Bearings - Install (Connecting Rods in Position).....	119
Installation Procedure	119
Connecting Rod Bearings - Remove (Connecting Rods in Position).....	118
Removal Procedure	118
Crankcase Breather - Install (Filtered Breather)....	83
Installation Procedure	83
Crankcase Breather - Install (Unfiltered Breather)..	83
Installation Procedure	83
Crankcase Breather - Remove (Filtered Breather).....	82
Removal Procedure	82
Crankcase Breather - Remove (Unfiltered Breather).....	81
Removal Procedure	81
Crankshaft - Install.....	129
Installation Procedure	129
Crankshaft - Remove.....	126
Removal Procedure	126
Crankshaft Front Seal - Remove and Install.....	66
Installation Procedure	66
Removal Procedure	66
Crankshaft Gear - Remove and Install	132
Installation Procedure	133
Removal Procedure	132

Crankshaft Main Bearings - Remove and Install (Crankshaft in Position)	121
Installation Procedure	123
Removal Procedure	121
Crankshaft Rear Seal - Install.....	60
Installation Procedure	60
Crankshaft Rear Seal - Remove.....	59
Removal Procedure	59
Cylinder Head - Install	92
Installation Procedure	92
Cylinder Head - Remove	89
Removal Procedure	89

D

Disassembly and Assembly Section.....	4
---------------------------------------	---

E

Electric Starting Motor - Remove and Install	141
Installation Procedure	141
Removal Procedure	141
Engine Oil Cooler - Install.....	49
Assembly Procedure	49
Installation Procedure	49
Engine Oil Cooler - Remove.....	48
Disassembly Procedure	49
Removal Procedure	48
Engine Oil Filter Base - Remove and Install.....	47
Installation Procedure	48
Removal Procedure	47
Engine Oil Pan - Install (Aluminum Oil Pan).....	109
Installation Procedure	109
Engine Oil Pan - Install (Cast Iron Oil Pan)	106
Installation Procedure	106
Engine Oil Pan - Remove (Aluminum Oil Pan)....	105
Removal Procedure	105
Engine Oil Pan - Remove (Cast Iron Oil Pan)	104
Removal Procedure	104
Engine Oil Pump - Install	51
Installation Procedure	51
Engine Oil Pump - Remove	50
Removal Procedure	50
Exhaust Elbow - Remove and Install.....	39
Installation Procedure	40
Removal Procedure	39
Exhaust Manifold - Remove and Install (Side Mounted Turbocharger Exhaust Manifold)	37
Installation Procedure	38
Removal Procedure	37
Exhaust Manifold - Remove and Install (Top Mounted Exhaust Manifold).....	35
Installation Procedure	36
Removal Procedure	35

F

Fan - Remove and Install	137
Installation Procedure	137
Removal Procedure	137
Fan Drive - Remove and Install	138
Installation Procedure	139
Removal Procedure	138
Flywheel - Install	58
Installation Procedure	58
Flywheel - Remove	57
Removal Procedure	57
Flywheel Housing - Remove and Install (Standard Housing)	61
Installation Procedure (Standard Housing)	62
Removal Procedure	61
Front Cover - Remove and Install	67
Installation Procedure	67
Removal Procedure	67
Fuel Filter Base - Remove and Install (Secondary Fuel Filter)	6
Installation Procedure	7
Removal Procedure	6
Fuel Injection Lines - Install	13
Installation Procedure	13
Fuel Injection Lines - Remove	11
Removal Procedure	11
Fuel Injection Pump - Install (With Boost Control) ..	21
Installation Procedure	21
Fuel Injection Pump - Install (With Electronic Governor)	19
Installation Procedure	19
Fuel Injection Pump - Remove (With Boost Control)	17
Removal Procedure	17
Fuel Injection Pump - Remove (With Electronic Governor)	15
Removal Procedure	15
Fuel Injection Pump Gear - Install	25
Installation Procedure	25
Fuel Injection Pump Gear - Remove	23
Removal Procedure	23
Fuel Injector - Install	28
Installation Procedure	28
Fuel Injector - Remove	27
Removal Procedure	27
Fuel Priming Pump - Remove and Install (Mechanical Priming Pump)	4
Installation Procedure	5
Removal Procedure	4

G

Gear Group (Front) - Remove and Install	68
Installation Procedure	70
Removal Procedure	68
Glow Plugs - Remove and Install	135
Installation Procedure	135
Removal Procedure	135

H

Housing (Front) - Install	78
Installation Procedure	78
Housing (Front) - Remove	76
Removal Procedure	76

I

Idle Gear - Install	74
Installation Procedure	74
Idle Gear - Remove	72
Removal Procedure	72
Important Safety Information	2
Inlet and Exhaust Valve Guides - Remove and Install	46
Installation Procedure	46
Removal Procedure	46
Inlet and Exhaust Valve Springs - Remove and Install	40
Installation Procedure	42
Removal Procedure	40
Inlet and Exhaust Valves - Remove and Install	43
Installation Procedure	44
Removal Procedure	43

L

Lifter Group - Remove and Install	95
Installation Procedure	96
Removal Procedure	95

P

Piston Cooling Jets - Remove and Install	111
Installation Procedure	112
Removal Procedure	111
Pistons and Connecting Rods - Assemble	115
Assembly Procedure	115
Pistons and Connecting Rods - Disassemble	113
Disassembly Procedure	113
Pistons and Connecting Rods - Install	117
Installation Procedure	117
Pistons and Connecting Rods - Remove	112
Removal Procedure	112

R

Rocker Shaft - Assemble	87
Assembly Procedure	87
Rocker Shaft - Disassemble	86
Disassembly Procedure	86
Rocker Shaft and Pushrod - Install	88
Installation Procedure	88
Rocker Shaft and Pushrod - Remove	85
Removal Procedure	85

T

Table of Contents..... 3
Turbocharger - Install (Side Mounted
Turbocharger)..... 31
Installation Procedure 31
Turbocharger - Install (Turbocharger Top
Mounted)..... 32
Installation Procedure 32
Turbocharger - Remove (Side Mounted
Turbocharger)..... 30
Removal Procedure 30
Turbocharger - Remove (Turbocharger Top Mounted
)..... 28
Removal Procedure 28

V

V-Belts - Remove and Install 136
Installation Procedure 137
Removal Procedure 136
Valve Mechanism Cover - Remove and Install 84
Installation Procedure 84
Removal Procedure 84
Vibration Damper and Pulley - Install 65
Installation Procedure 65
Vibration Damper and Pulley - Remove 64
Removal Procedure 64

W

Water Pump - Install 54
Installation Procedure 54
Water Pump - Remove 53
Removal Procedure 53
Water Separator and Fuel Filter (Primary) - Remove
and Install 8
Installation Procedure 9
Removal Procedure 8
Water Temperature Regulator - Remove and
Install 56
Installation Procedure 56
Removal Procedure 56

